



# Busy Bee Tools

## Panel Lifting Cart BBPANEL



### User's Manual



COPYRIGHT © 2024 BY BUSY BEE TOOLS LTD.

NO PORTION OF THIS MANUAL MAY  
BE REPRODUCED WITHOUT THE WRITTEN  
CONSENT OF BUSY BEE TOOLS LTD.



## Introduction

Introducing our new Panel Lifting Cart, an essential addition to any woodworking shop. Designed for ease of assembly and constructed with robust materials, this cart ensures durability and reliability in your daily operations. Its user-friendly design makes maneuvering large panels effortless, enhancing both safety and efficiency in the workspace. At Busy Bee Tools, we take pride in offering high-quality, well-crafted products that meet the demands of professional woodworkers and hobbyists alike. Our commitment to excellence is reflected in every product we introduce, ensuring you always have the best tools for your projects.

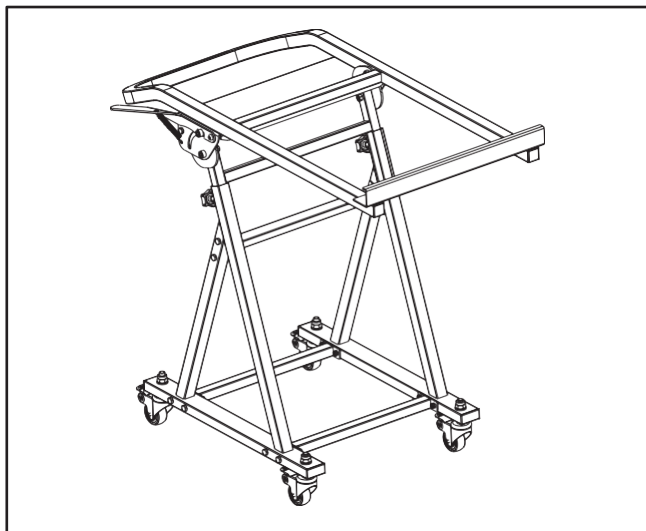

Figure 1.

## Inventory

Loose Items (Figure 2)	Qty
A. Lift Assembly .....	1
B. Extension Spring 1.5 x 10 x 80 .....	1
C. Lock Lever .....	1
D. Swivel Lock Casters .....	4
E. Stands .....	2
F. Lower Cross Beams .....	2
G. Upper Cross Beam .....	1
H. Hardware (Not Shown)	
—Hex Bolts M8-1.25 x 65 .....	8
—Hex Bolts M8-1.25 x 45 .....	4

—Button Head Cap Screw M8-1.25 x 16 ...	1
—Flat Washers 12mm .....	4
—Lock Nuts M12-1.75 .....	4
—Lock Nuts M8-1.25 .....	12
—Knob Bolts M8-1.25 x 20 .....	2

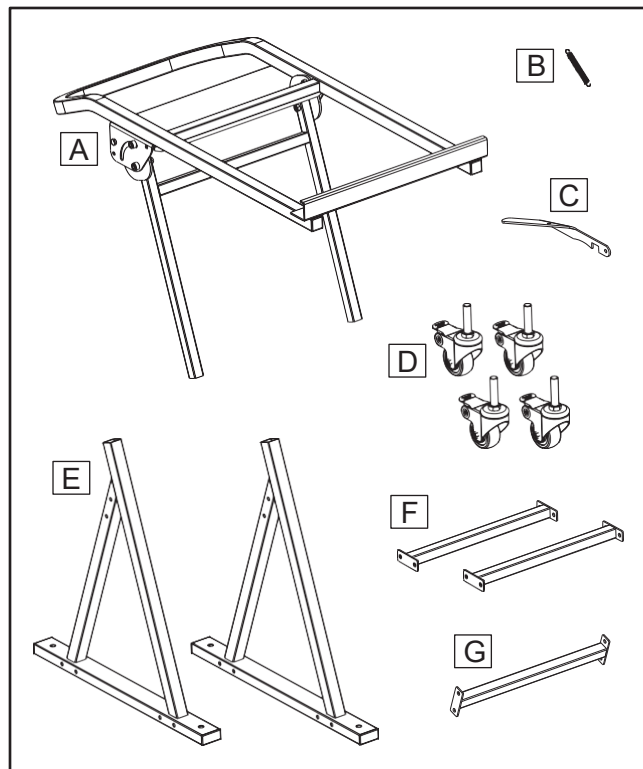

Figure 2. Inventory.

## Assembly

Tools Needed	Qty
Wrenches or Sockets 13mm .....	2
Open-End Wrench 19mm .....	1

**To assemble cart:**

1. Attach (2) stands to (2) lower cross beams with (8) M8-1.25 x 65 hex bolts and M8-1.25 lock nuts (see **Figure 3**).

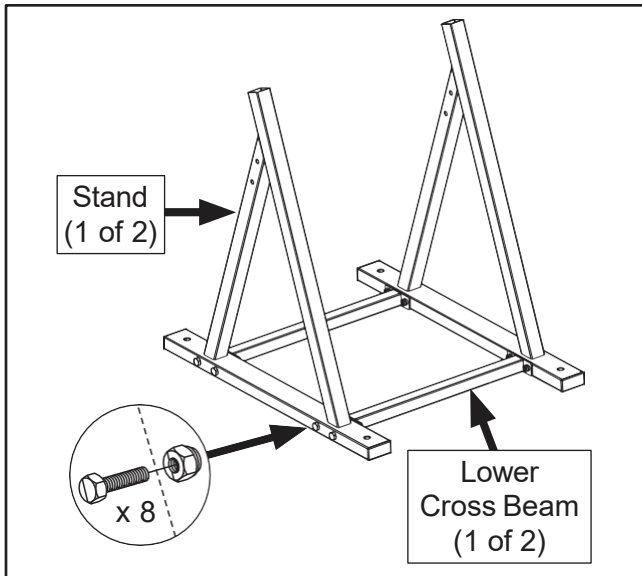

**Figure 3.** Stands attached to lower cross beams.

2. Attach upper cross beam to stands with (4) M8-1.25 x 45 hex bolts and M8-1.25 lock nuts (see **Figure 4**).
3. Attach (4) swivel lock casters to stands with (4) 12mm flat washers and M12-1.75 lock nuts (see **Figure 4**).

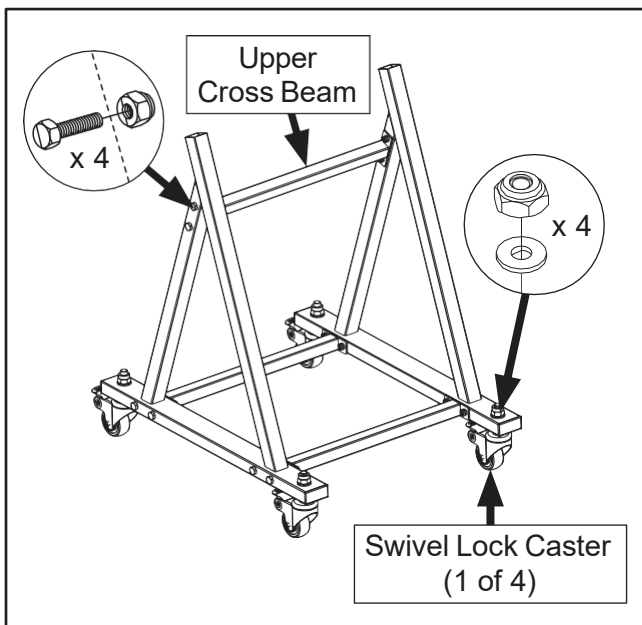

**Figure 4.** Upper cross beam and swivel lock casters attached to stands.

4. Lock casters to keep stand stationary in following steps.
5. Loosen (2) knob bolts, if installed, in stands enough to complete following step.
6. Slide lift assembly posts all the way into stands, as shown in **Figure 5**, then secure with knob bolts.

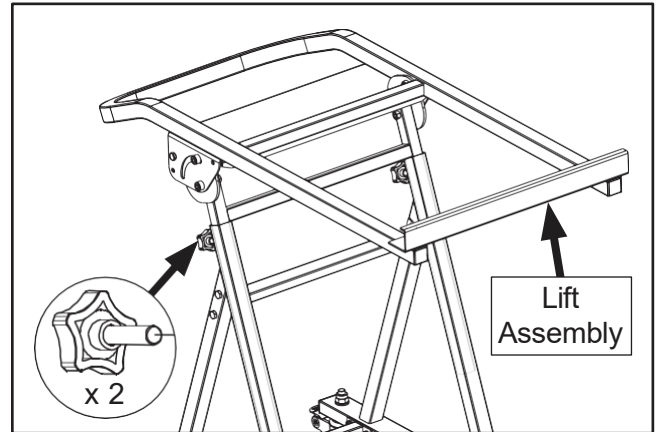

**Figure 5.** Lift assembly installed on stands.

7. Attach lock lever to lift assembly with M8-1.25 x 16 button head cap screw and extension spring, as shown in **Figure 6**.

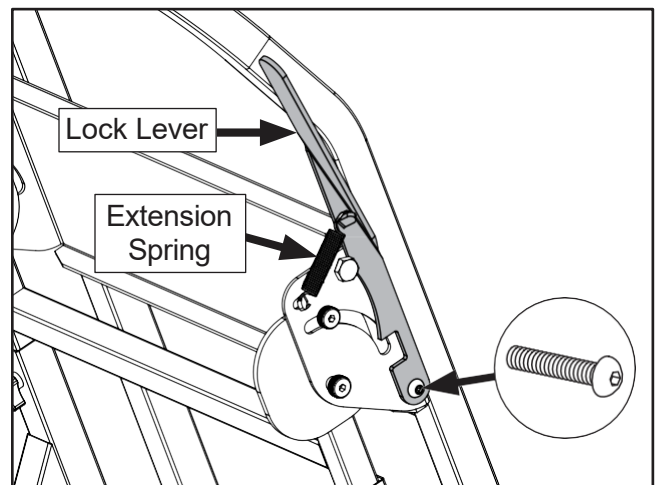

**Figure 6.** Lock lever and extension spring installed.

## Operation

This product can be used to simply transport a panel from one location to another, to unload a panel from a truck or workbench, or to lift a panel to feed it onto a workbench, table saw, etc.

### To operate cart:

1. Use lift bar to move lift frame to horizontal position (see **Figure 7**).

**Note:** Lock lever will lock lift frame position once horizontal.

2. Loosen height lock knobs shown in **Figure 7**, adjust lift frame to desired height, then tighten lock knobs to secure.

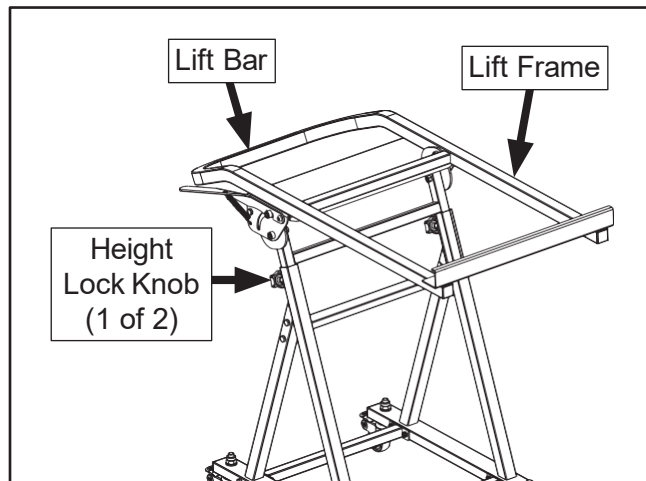

**Figure 7.** Lift frame in horizontal position.

3. Lift lock lever to release lift frame, then return frame to vertical position (see **Figure 8**).

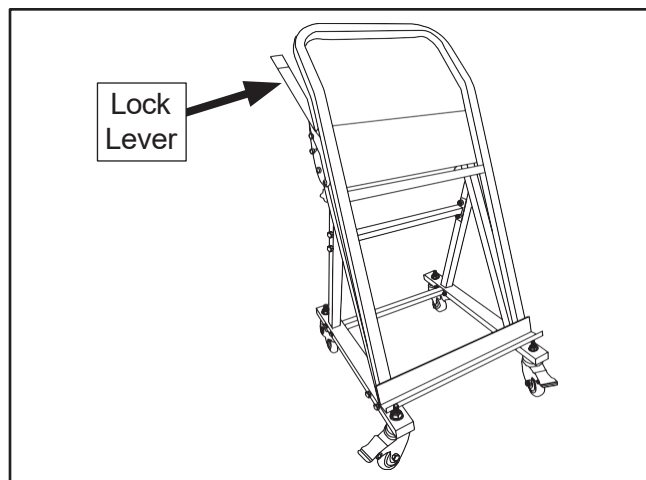

**Figure 8.** Lift frame in vertical position.

4. Lock casters to keep cart stationary.
5. Load panel onto lift frame, centering panel on cart (see **Figure 9**).

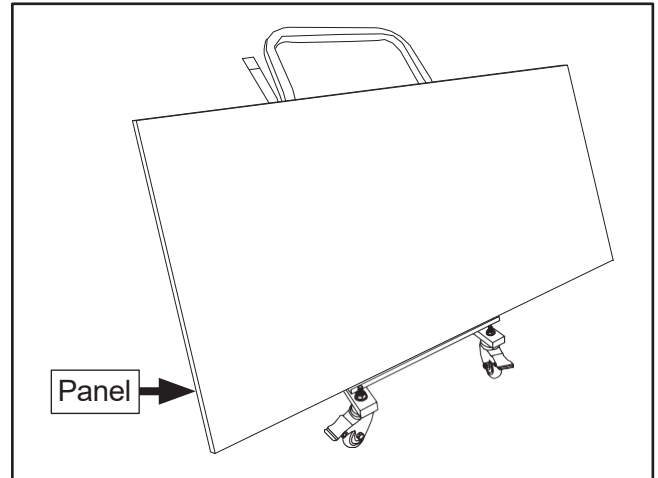

**Figure 9.** Panel centered on cart.

6. Unlock casters.
7. Push cart to desired location, face cart and panel away from lifting location, then lock casters.
8. Move the lift frame until lock lever locks it in horizontal position, then unload panel (see **Figure 10**).

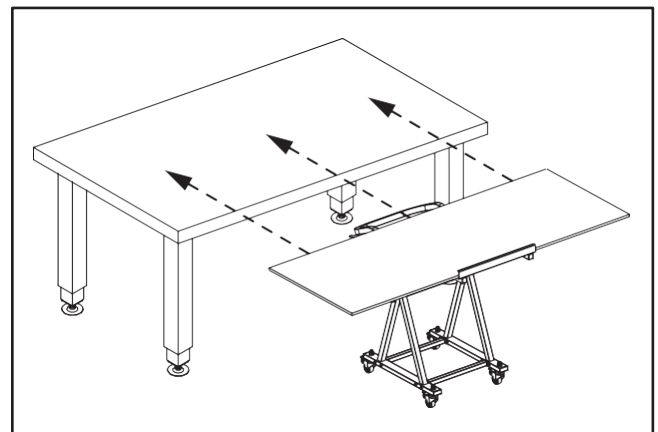

**Figure 10.** Unloading panel from cart.

# Parts Breakdown & List

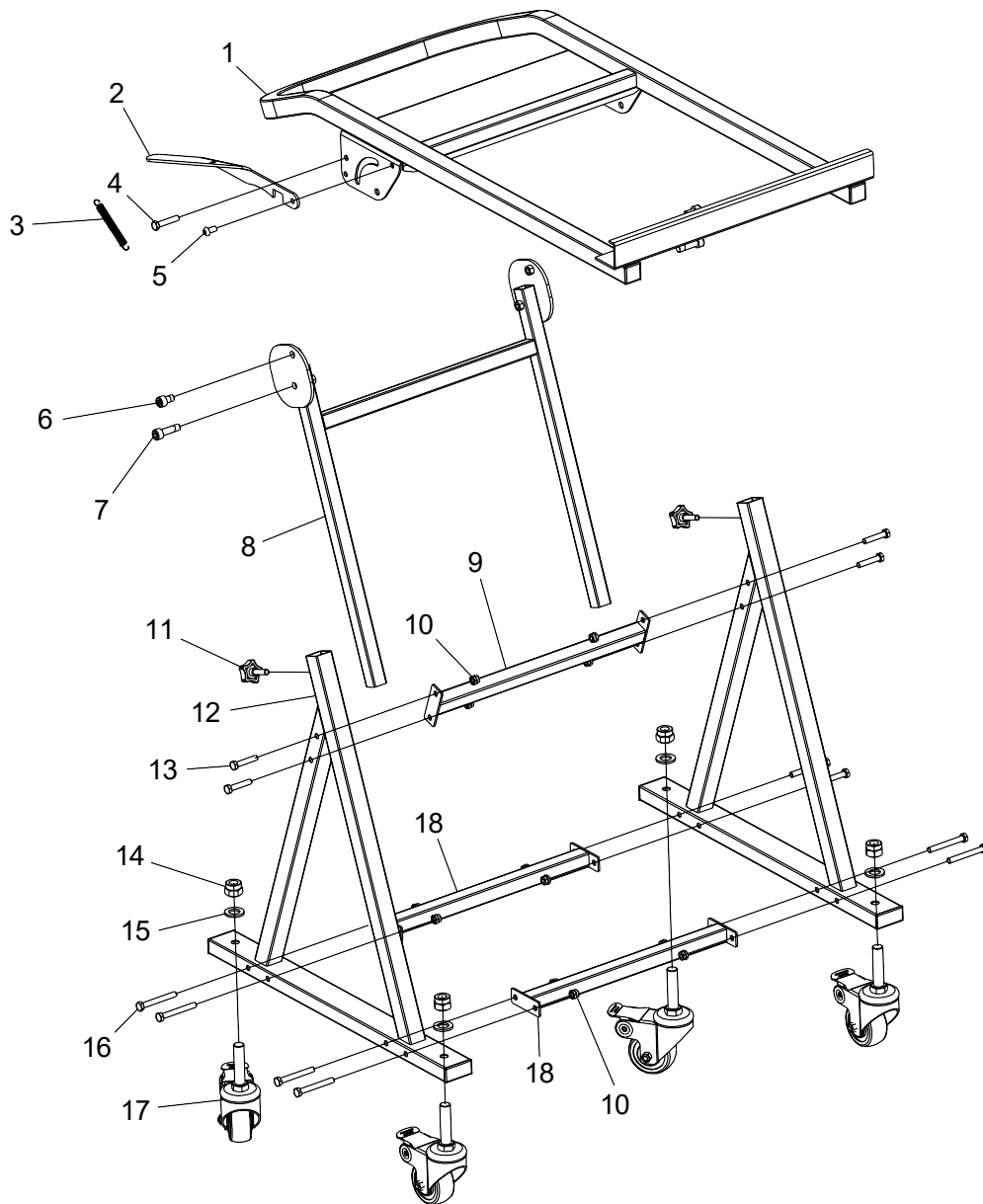

**Parts List:**

Ref. #	Part #	Description	Qty
1	PBBPANEL01	Lift Frame	1
2	PBBPANEL02	Lock Lever	1
3	ZSEX151080	Extension Spring 1.5X10X80mm	1
4	ZHXBOM812535	Hex Bolt M8-1.25X35mm	8
5	ZBTSM812516	Screw Button HD M8-1.25X16mm	1
6	ZSSHM812513	Screw Shoulder M8-1.25X13mm	2
7	ZSSHM812535	Screw Shoulder M8-1.25X35mm	2
8	PBBPANEL08	Height Bracket	1
9	PBBPANEL09	Upper Cross Beam 15-7/8"	1
10	ZLKNM812500	Nut Lock M8-1.25	12
11	ZKBOM812520	Knob 5-Lobe M8-1.25X20mm	2
12	PBBPANEL012	Stand	2
13	ZHXBOM812545	Bolt Hex M8-1.25X45mm	4
14	ZLKNM121750	Nut Lock M12-1.75	4
15	ZFWM120000	Washer Flat M12	4
16	ZHXBOM812565	Bolt Hex M8-1.25X65mm	8
17	PBBPANEL017	Caster 3" Locking Swivel M12-1.75	4
18	PBBPANEL018	Lower Cross Beam 14-15/16"	2