

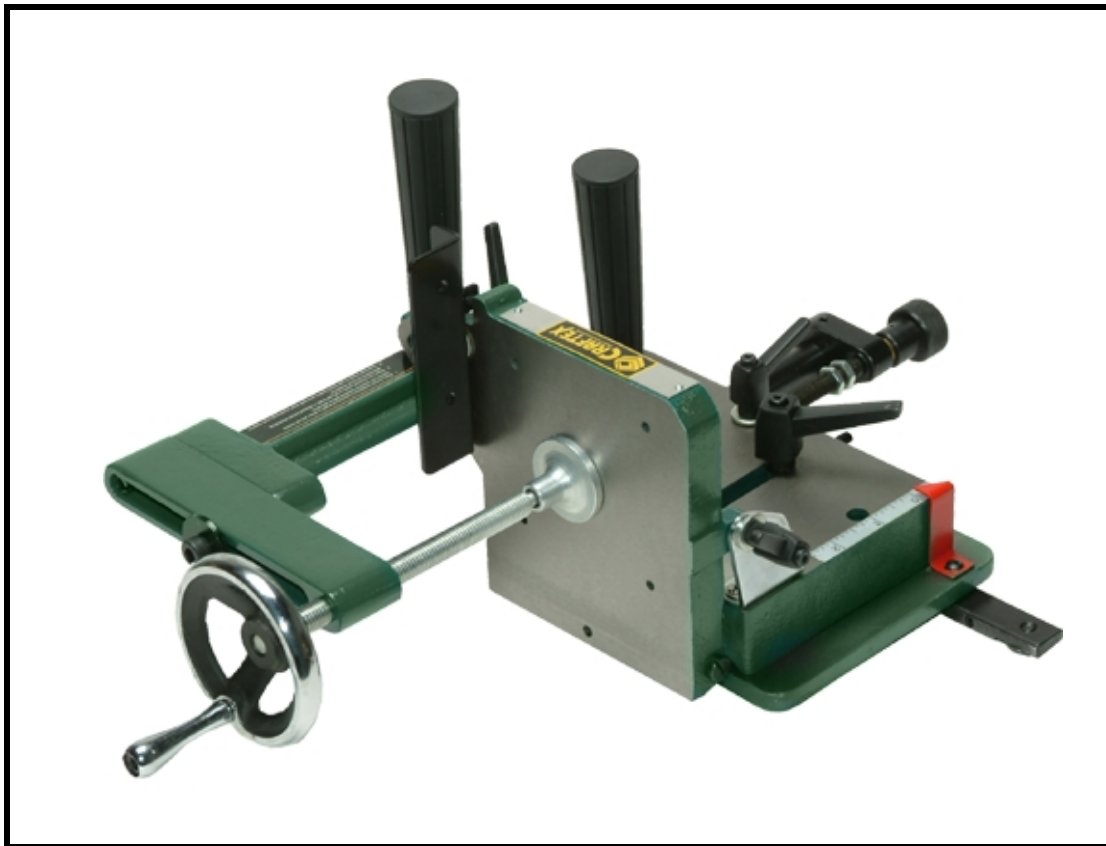

CT084 TENONING JIG

User Manual



Warning

This jig should only be used with suitable tablesaws. Please refer to your tablesaw's manual for further information. All tablesaw safety features and guards must be kept in place and in good working order during the use of this jig.

PRODUCT SPECIFICATIONS

Tenoning Jig

- Fits left and right tilting table saws with 3/8" deep x 3/4" wide miter gage grooves. Left tilt application requires some assembly.
- Handles stock up to 3-1/4" thick.
- Adjustable guide bar to better-fit miter gage groove.
- Two large grip-feed handles.
- Multi-position control levers.
- Adjustable bevel-angle 90 to 45 degrees.
- Adjustable backstop 90 to 45 degrees, with adjustable 90 degree positive-stop.
- Extra large clamp hand-wheel.

SAFETY INSTRUCTIONS

GENERAL SAFETY INSTRUCTIONS

Operating a Tenoning Jig and Table Saw can be dangerous if safety and common sense are ignored. The operator must be familiar with the operation of the tool. Read this manual to understand this Tenoning Jig. **DO NOT** operate this Tenoning Jig if you do not fully understand the limitations of this tool. **DO NOT** modify this Tenoning Jig in any way. **REMEMBER:** Your personal safety is your responsibility.

BEFORE USING THE TENONING JIG

WARNING

To avoid serious injury and damage to the tool, read and follow all of the Safety and Operating Instructions before operating the Tenoning Jig.

1. **READ** the entire Owner's Manual. **LEARN** how to use the tool for its intended applications.
2. **AVOID A DANGEROUS WORKING ENVIRONMENT. DO NOT** use electrical tools in a damp environment or expose them to rain.
3. **DO NOT** use electrical tools in the presence of flammable liquids or gases.
4. **ALWAYS** keep the work area clean, well lit, and organized. **DO NOT** work in an environment with floor surfaces that are slippery from debris, grease, and wax.

SAFETY INSTRUCTIONS (cont.)

5. **KEEP VISITORS AND CHILDREN AWAY. DO NOT** permit people to be in the immediate work area, especially when the electrical tool is operating.
6. **DO NOT FORCE THE TOOL** to perform an operation for which it was not designed. It will do a safer and higher quality job by only performing operations for which the tool was intended.
7. **WEAR PROPER CLOTHING. DO NOT** wear loose clothing, gloves, neckties, or jewelry. These items can get caught in the machine during operations and pull the operator into the moving parts. The user must wear a protective cover on their hair, if the hair is long, to prevent it from contacting any moving parts.
8. **ALWAYS WEAR EYE PROTECTION.** Any power tool can throw debris into the eyes during operations, which could cause severe and permanent eye damage. **ALWAYS** wear Safety Goggles when operating power tools.
9. **WEAR A DUST MASK TO PREVENT INHALING DANGEROUS DUST OR PARTICLES.**
10. **ALWAYS UNPLUG THE TOOL FROM THE ELECTRICAL RECEPTACLE** when making adjustments, changing parts or performing any maintenance.
11. **KEEP PROTECTIVE GUARDS IN PLACE AND IN WORKING ORDER.**
12. **AVOID ACCIDENTAL STARTING.** Make sure that the power switch is in the "OFF" position before plugging in the power cord to the electrical receptacle.
13. **REMOVE ALL MAINTENANCE TOOLS** from the immediate area prior to turning the tool "ON".
14. **USE ONLY RECOMMENDED ACCESSORIES.** Use of incorrect or improper accessories could cause serious injury to the operator and cause damage to the tool. If in doubt, check the instruction manual that comes with that particular accessory.
15. **NEVER LEAVE A RUNNING TOOL UNATTENDED.** Turn the power switch to the "OFF" position. **DO NOT** leave the tool until it has come to a complete stop.
16. **DO NOT STAND ON A TOOL.** Serious injury could result if the tool tips over or you accidentally contact the tool.
17. **DO NOT** store anything above or near the tool where anyone might try to stand on the tool to reach it.
18. **MAINTAIN YOUR BALANCE. DO NOT** extend yourself over the tool. Wear oil resistant rubber-soled shoes. Keep floor clear of debris, grease and wax.
19. **MAINTAIN TOOLS WITH CARE.** Always keep tools clean and in good working order. Keep all blades and tool bits sharp.
20. **EACH AND EVERY TIME, CHECK FOR DAMAGED PARTS PRIOR TO USING THE TOOL.** Carefully check all guards to see that they operate properly, are not damaged, and perform their intended functions. Check for alignment, binding or breaking of moving parts. A guard or other part that is damaged should be immediately repaired or replaced.
21. **DO NOT OPERATE TOOL IF UNDER THE INFLUENCE OF DRUGS OR ALCOHOL.**
22. **SECURE ALL WORK.** When it is possible, use clamps or jigs to secure the workpiece. This is safer than attempting to hold the workpiece with your hands.
23. **STAY ALERT, WATCH WHAT YOU ARE DOING, AND USE COMMON SENSE WHEN OPERATING A POWER TOOL. DO NOT USE A TOOL WHILE TIRED OR UNDER THE INFLUENCE OF DRUGS, ALCOHOL, OR MEDICATION.** A moment of inattention while operating power tools may result in serious personal injury.

WARNING

This Tenoning Jig is for indoor use only. Do not expose to rain or use in damp locations.

This jig should only be used with suitable tablesaws. Please refer to your tablesaw's manual for further information. All tablesaw safety features and guards must be kept in place and in good working order during the use of this jig.

SPECIFIC SAFETY INSTRUCTIONS FOR TENONING JIGS

The operation of any Tenoning Jig or Table Saw can result in debris being thrown into your eyes, which can result in severe eye damage. **ALWAYS** wear Safety Goggles when operating the Tenoning Jig. Always wear Safety Goggles. Keep your thumbs and fingers away from the table saw blade.

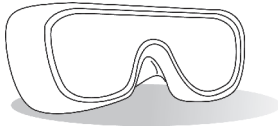

Basic precautions should always be followed when using your Tenoning Jig. To reduce the risk of injury, electrical shock or fire, comply with the safety rules listed below:

1. **READ** and understand the instruction manual before operating the Tenoning Jig and Table Saw.
2. **DO NOT OPERATE THIS MACHINE** until it is assembled and installed according to the instructions.
3. **OBTAIN ADVICE FROM YOUR SUPERVISOR, instructor, or another qualified person** if you are not familiar with the operation of this machine.
4. **ALWAYS** replace blade guard of saw when finished using the Tenoning Jig.
5. **REMOVE ADJUSTING KEYS AND WRENCHES.** Form habit of checking to see that keys and adjusting wrenches are removed from tool before operating.
6. **MAKE CERTAIN** workpiece is securely clamped in place and all locking handles are properly tightened before operating.
7. **MAKE SURE** machine power is off and blade is stopped before attempting adjustment to Jig or workpiece.

8. **KEEP** both hands on operating handles provided when processing work material.
9. **WEAR PROPER APPAREL.** No loose clothing, gloves, neckties, rings, bracelets, or other jewelry to get caught in moving parts. Non-slip footwear is recommended. Wear protective hair covering to contain long hair.
10. **DO NOT** leave the Tenoning Jig plugged into the electrical outlet. Unplug Tenoning Jig from the outlet when not in use and before servicing, changing bags, unclogging and cleaning.
11. **ALWAYS** turn the power switch “OFF” before unplugging the Tenoning Jig.
12. **DO NOT** handle the plug or Tenoning Jig with wet hands.
13. **USE** only as described in this manual. **USE** accessories only recommended for your Tenoning Jig.
14. **DO NOT** use the Tenoning Jig as a toy. **DO NOT** use near or around children.
15. **PERIODICALLY INSPECT** for damaged or missing parts. **NEVER** operate the Tenoning Jig with damaged or missing parts.
16. **SAVE THESE INSTRUCTIONS.** Refer to them frequently and use them to instruct other users.

WARNING

This jig should only be used with suitable tablesaws. Please refer to your tablesaw’s manual for further information. All tablesaw safety features and guards must be kept in place and in good working order during the use of this jig.

CARTON CONTENTS

UNPACKING AND CHECKING CONTENTS

This Tenoning Jig will require a minimal amount of assembly. Allen wrenches are provided for assembly.

Remove all of the parts from the shipping box and lay them on a clean work surface. Compare the items to Figure 1; verify that all items are accounted for before discarding the shipping box.

Fig. 1

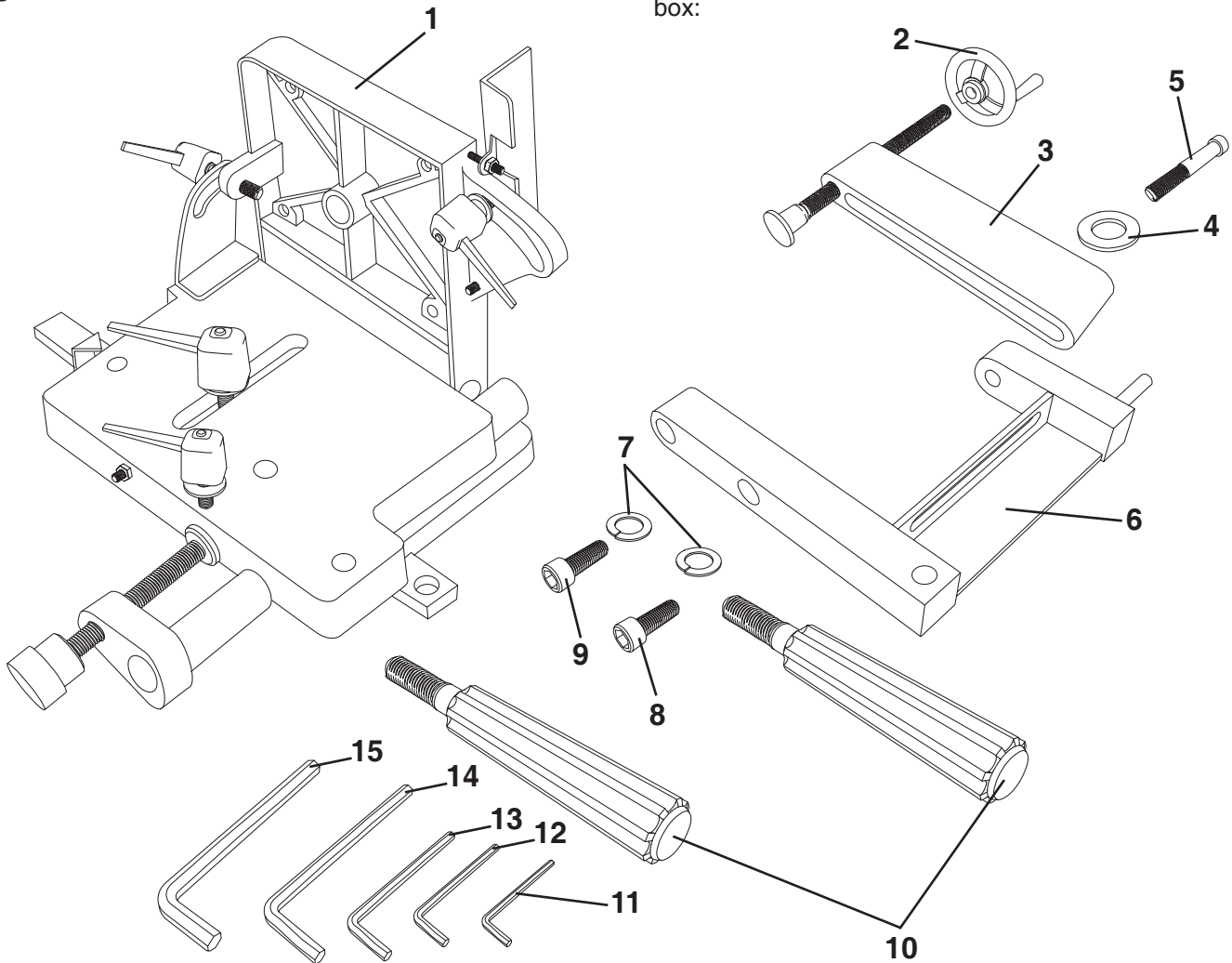

⚠ WARNING

If any parts are missing, do not attempt to use the Tenoning Jig. The Tenoning Jig can only be used after all the parts have been obtained and installed correctly.

This jig should only be used with suitable tablesaws. Please refer to your tablesaw's manual for further information. All tablesaw safety features and guards must be kept in place and in good working order during the use of this jig.

The following items are to be provided in the shipping box:

- | | | |
|--|---------------------------------|------------------------|
| 1. Base and Vertical Work Support Assembly | 6. Clamp Arm | 11. Allen Wrench 2.5mm |
| 2. Hand Wheel | 7. Lockwasher M10 (2) | 12. Allen Wrench 3mm |
| 3. Clamp Assembly | 8. Socket Head Screw M10 x 25mm | 13. Allen Wrench 4mm |
| 4. Flat Washer M8 | 9. Socket Head Screw M10 x 20mm | 14. Allen Wrench 6mm |
| 5. Socket Head Screw M8 x 50mm | 10. Handles (2) | 15. Allen Wrench 8mm |

ASSEMBLY

⚠ WARNING

DISCONNECT SAW FROM THE POWER SOURCE.

This jig should only be used with suitable tablesaws. Please refer to your tablesaw's manual for further information. All tablesaw safety features and guards must be kept in place and in good working order during the use of this jig.

Fig. 2

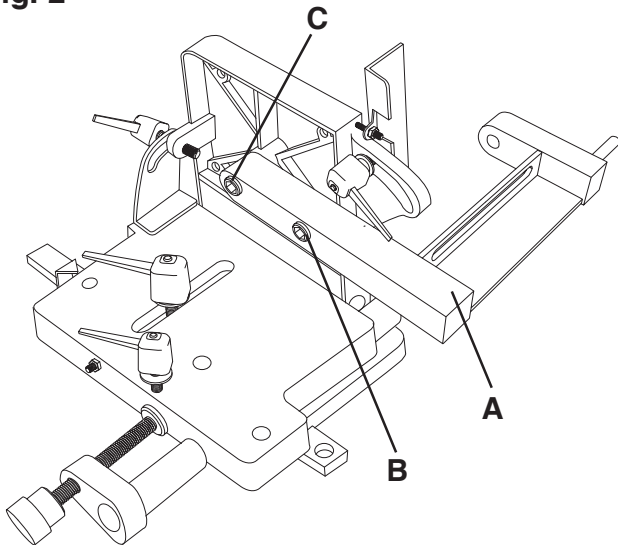

1. Fasten clamp arm (A) to the back of the work support plate using the socket head screw M10 x 25mm (B), socket head screw M10 x 20mm (C), and two lock washers, not shown. See **Figure 2**.

Fig. 3

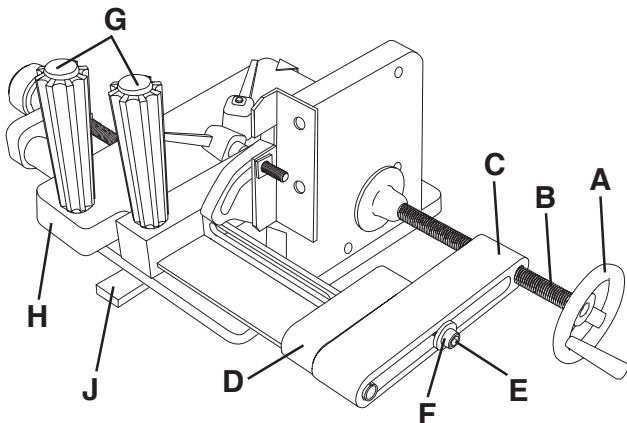

2. Slide the hand wheel (A) onto the end of the thread shaft (B) of the clamp assembly (C). Tighten setscrew on hub of hand wheel. See **Figure 3**.
3. Fasten clamp assembly (C) to clamp arm (D) using socket head screw M8 x 50mm (E) and flat washer (F). See **Figure 3**.
4. Fasten handles (G) to clamp arm and base (H). See **Figure 3**.

5. **IMPORTANT:** The guide bar (J), located under the base of the Tenoning Jig, has been preset at the factory for operation on right tilting arbor saws. See **Figure 3**. If you are using the Tenoning Jig on a right tilting arbor saw, proceed with instructions for “**ADJUSTING GUIDE BAR TO TABLE SLOT**”. If you are using the Tenoning Jig on a left tilting arbor saw, the guide bar must be relocated on the base of the Tenoning Jig, as follows:

FOR LEFT TILTING ARBOR SAWS ONLY

Fig. 4

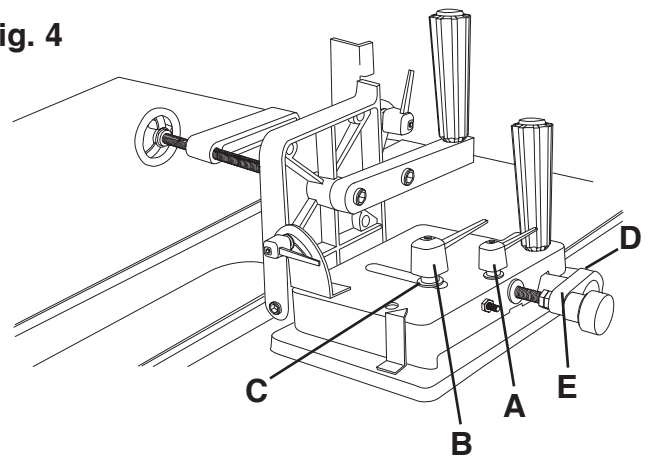

1. Loosen small lock handle (A). Loosen and remove large lock handle (B) and flat washer (C), from Tenoning Jig. **NOTE:** Each lock handle is spring-loaded and can be repositioned by pulling up on the handle and repositioning it on the nut located underneath the handle. See **Figure 4**.
2. Using a 3mm allen wrench, loosen setscrew (D) and remove micro-adjustment assembly (E) from Tenoning Jig. See **Figure 4**.

Fig. 5

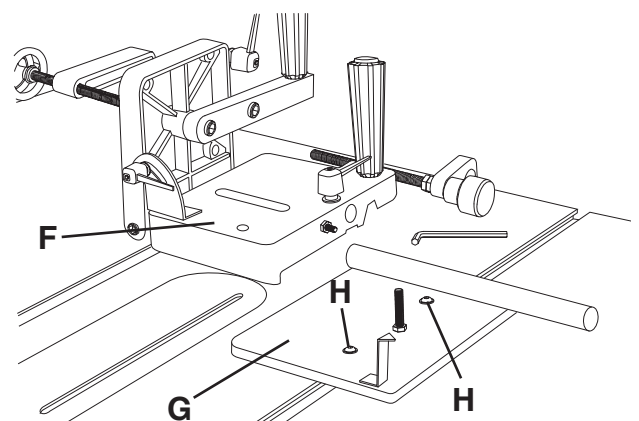

3. Lift Jig assembly (F) from base (G). Loosen and remove two button head screws and flat washers (H) from the base. See **Figure 5**.

Fig. 6

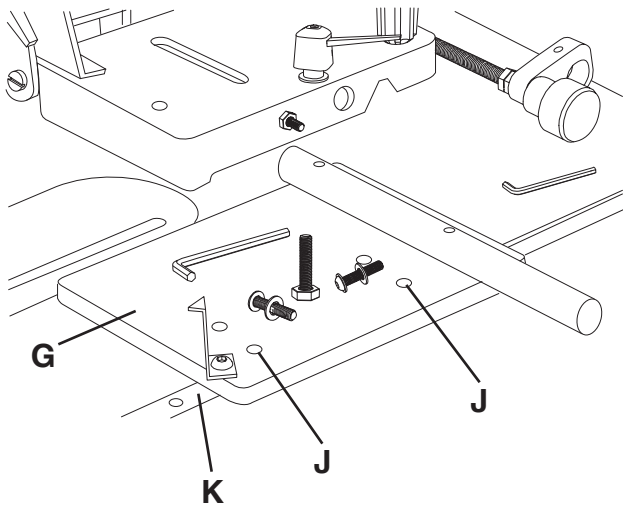

- Slide base (G) forward until two holes (J) are aligned with holes in guide bar (K). See **Figure 6**. Fasten base to guide bar with two button head screws and flat washers removed in previous step.

Fig. 7

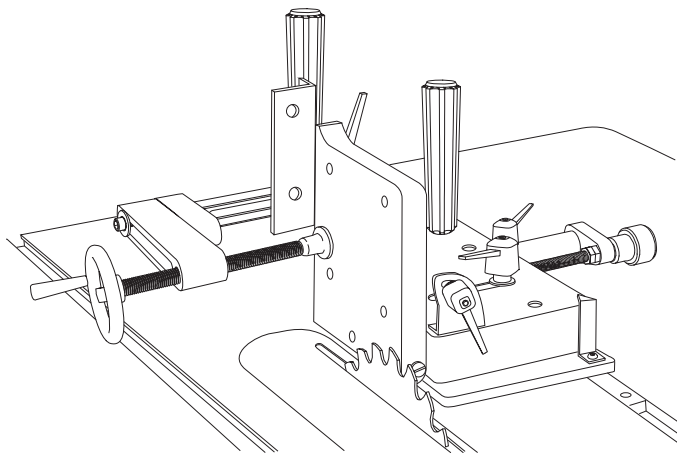

- Reassemble items that were removed in STEPS 1, 2 and 3 in reverse order. **Figure 7** shows the Tenoning Jig reassembled for a Left Tilting Table Saw.

⚠ WARNING

This jig should only be used with suitable tablesaws. Please refer to your tablesaw's manual for further information. All tablesaw safety features and guards must be kept in place and in good working order during the use of this jig.

ADJUSTING GUIDE BAR TO TABLE SLOT

⚠ WARNING

DISCONNECT SAW FROM THE POWER SOURCE.

Fig. 8

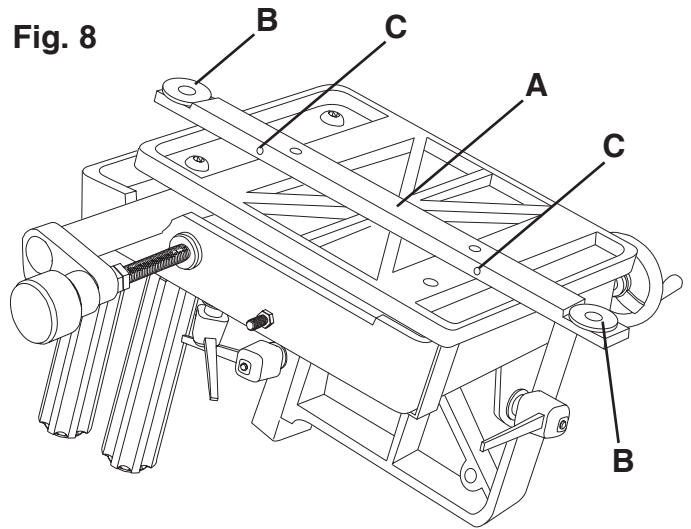

- The Tenoning Jig is furnished with an adjustable guide bar (A), which allows the Jig to be custom-fit to your saw, eliminating any side-to-side play. Also, there is a T-slot washer (B) on each end of the guide bar to keep the Tenoning Jig from lifting during operation. **NOTE:** T-slot washers need to be removed if your table saw is not equipped with T-slotted miter gage slots. See **Figure 8**.

Fig. 9

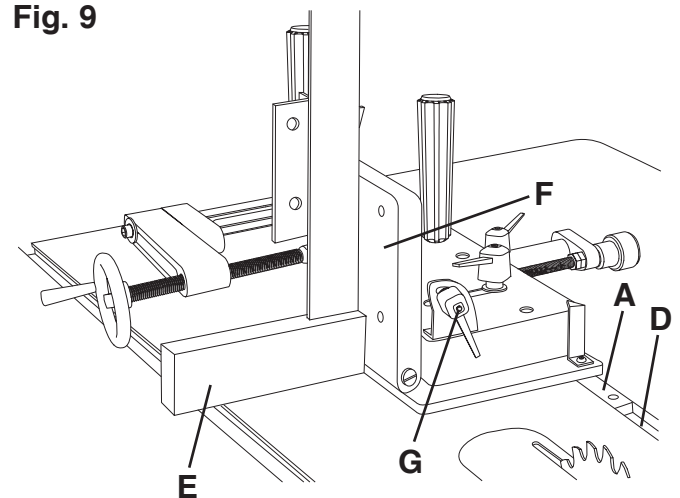

- Place Tenoning Jig guide bar (A) into left miter slot (D) of machine and slide miter gage back and forth to determine if there is any side-to-side play. If there is no side-to-side play and the Tenoning Jig slides easily through the miter slot of the machine, no adjustment is necessary. If the Tenoning Jig fits too snugly or there is excessive play between the guide bar and miter slot, an adjustment is needed. Proceed to next step. See **Figure 9**.

- Remove Tenoning Jig from machine and place it upside down.
- Using the 2.5mm allen wrench (not shown), adjust screws (C), clockwise to eliminate play, or counterclockwise to provide a looser fit between the guide bar and miter slot. See **Figure 8**.
- Insert the Tenoning Jig back into the miter slot of the table saw. Recheck the fit by sliding miter gage back and forth to determine if there is any side-to-side play. If more adjustments are needed, repeat Steps 3, 4 and 5.

ALIGNING TENONING JIG

⚠ WARNING

DISCONNECT SAW FROM THE POWER SOURCE.

- Place the Tenoning Jig guide bar (A) into the left miter gage slot (D). See **Figure 9**.
- Using a square (E), check that the vertical work support plate (F) is 90 degrees to the table surface. If an adjustment is necessary, loosen lock handle (G), move vertical work support plate until it is 90 degrees to the table surface and tighten lock handle. **NOTE:** The lock handle is spring-loaded and can be repositioned by pulling out on the handle and rotating the handle clockwise or counterclockwise. See **Figure 9**.

Fig. 10

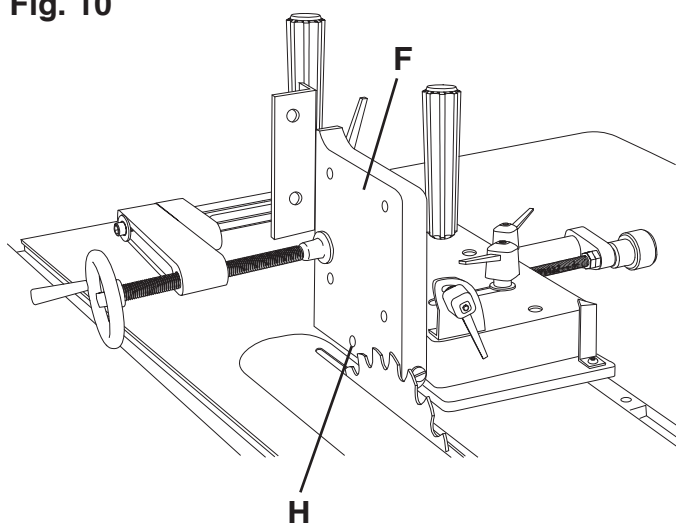

- With the vertical work support plate (F) adjusted at 90 degrees to the table surface, tighten positive stop setscrew (H) until it bottoms. This positive stop setscrew enables you to rapidly reposition the vertical work support plate to 90 degrees. See **Figure 10**.

⚠ WARNING

This jig should only be used with suitable tablesaws. Please refer to your tablesaw's manual for further information. All tablesaw safety features and guards must be kept in place and in good working order during the use of this jig.

Fig. 11

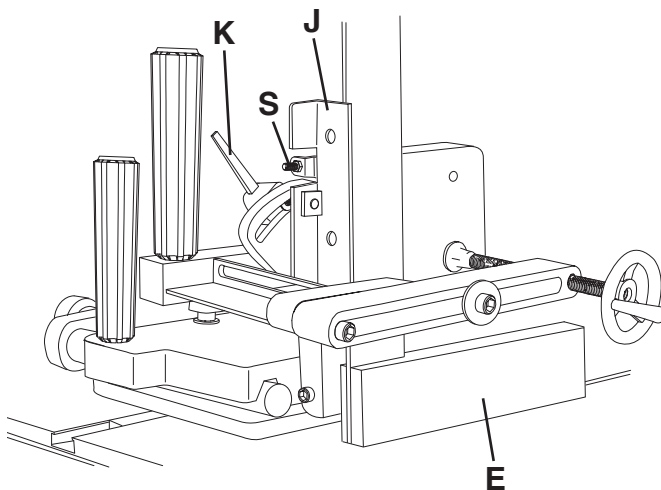

- Using a square (E) check that the face of the backstop (J) is 90 degrees to the table surface. If an adjustment is necessary, loosen lock lever (K), adjust backstop accordingly and retighten lock handle. **NOTE:** The lock handle is spring-loaded and can be repositioned by pulling out on the handle and rotating the handle clockwise or counterclockwise. When the backstop is 90-degree to the table, adjust the setscrew (S) until it touches the backstop. Tighten the jam nut. Setscrew (S) acts as a positive stop and allows you to quickly position the backstop back to the 90-degree position after it has been tilted. See **Figure 11**.

Fig. 12

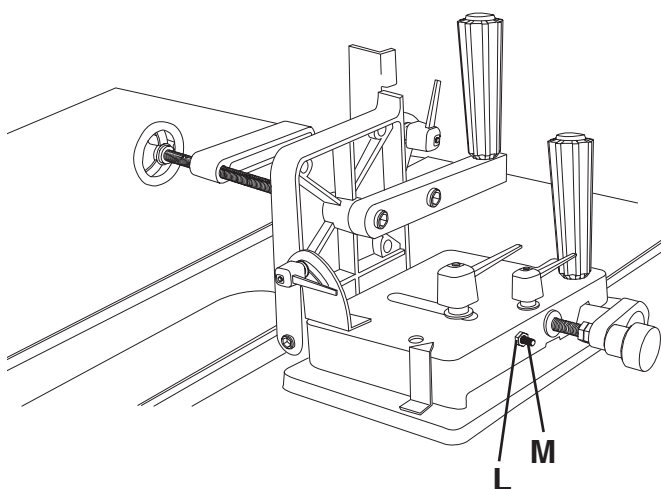

- Loosen nut (L) and turn setscrew (M) counterclockwise two or three turns. See **Figure 12**.

Fig. 13

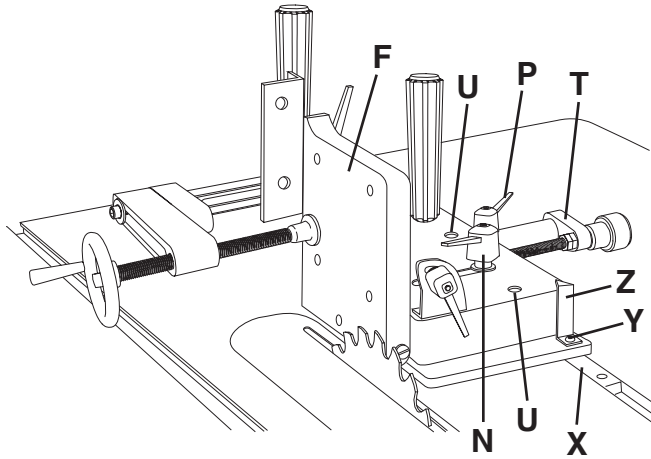

6. Loosen two lock handles (N) and (P) and move the Jig until the vertical work support plate (F) is against the saw blade and tighten lock handle (N). **NOTE:** The lock handles (N) and (P) are spring-loaded and can be repositioned by pulling out on the handle and rotating the handle clockwise or counterclockwise. See **Figure 13**.
7. Check if the vertical support plate (F) is parallel to the saw blade. See **Figure 13**.
8. If an adjustment is necessary, Loosen lock handles (N) and (P).
9. Loosen setscrew (T) and remove the micro-adjustment assembly from Tenoning jig.
10. Align the two holes (U) in the jig with the two screws (not shown) in the guide bar (X).
11. Loosen two guide bar screws inside holes (U) and move jig until vertical work support plate (F) is parallel with the saw blade.
12. Tighten the two guide bar screws inside holes (U).
13. Reinstall the micro-adjustment assembly and tighten setscrew (T). See **Figure 13**.
14. Move vertical work support plate (F) 1/8" away from saw blade; tighten lock handle (N). See **Figure 13**.
15. Loosen screw (Y) and adjust pointer (Z) to the 1/8" mark on the scale. Retighten screw (Y). See **Figure 13**.
16. Turn screw (M) clockwise until it bottoms. This prevents the vertical work support plate (F) from accidentally being moved into the saw blade; tighten nut (L). See **Figure 12**.

ADJUSTMENTS

⚠ WARNING

DISCONNECT SAW FROM THE POWER SOURCE.

Fig. 14

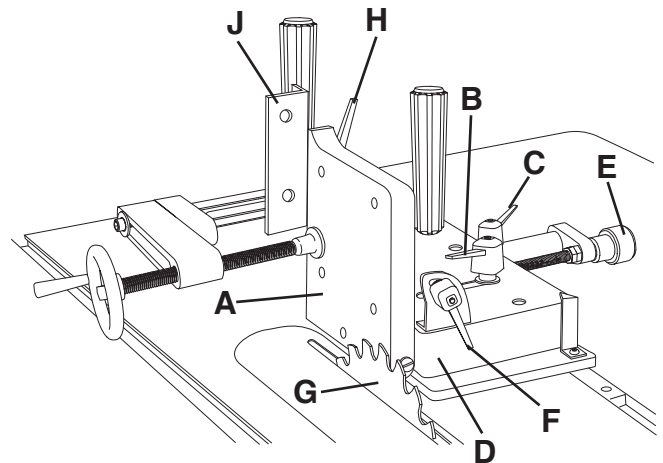

1. For rapid adjustment of the vertical work support plate (A) toward or away from the saw blade (G), loosen lock handle (B) and (C) and move Jig (D) as necessary. Tighten lock handles after rapid adjustments are made. See **Figure 14**.
2. Fine adjustments of the vertical work support plate (A) can be accomplished by loosening lock handle (B) and rotate knob (E) until plate (A) is at the desired position. Tighten lock handle (B) after fine adjustments are made. See **Figure 14**.
3. To tilt the vertical work support plate (A), loosen lock handle (F), tilt vertical work support plate (A) to the desired angle and tighten lock handle. See **Figure 14**.
4. To cut an angle tenon, loosen lock handle (H) and adjust backstop (J) to desired angle and tighten lock handle.
5. **IMPORTANT:** The Tenoning Jig is not equipped with a bevel scale for the positioning of the backstop (J) or vertical work support plate (A). The desired angle of the workpiece should be cut prior to set up of the Tenoning Jig.

⚠ WARNING

This jig should only be used with suitable tablesaws. Please refer to your tablesaw's manual for further information. All tablesaw safety features and guards must be kept in place and in good working order during the use of this jig.

SET UP

⚠ WARNING

DISCONNECT SAW FROM THE POWER SOURCE.

Fig. 15

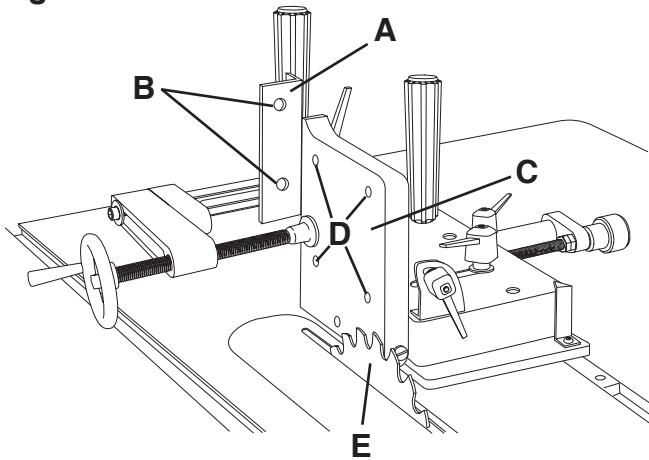

1. To eliminate chip-out of the workpiece when performing cheek cuts, an auxiliary wooden backup board can be fastened to the backstop (A) with two wood screws (not included) through the two pre-drilled holes (B) in the backstop. See **Figure 15**.
2. An auxiliary board can also be added to the vertical work support plate (C) through four pre-drilled holes (D). This auxiliary board will help prevent the saw blade (E) from contacting the Tenoning Jig. See **Figure 15**.

⚠ WARNING

This jig should only be used with suitable tablesaws. Please refer to your tablesaw's manual for further information. All tablesaw safety features and guards must be kept in place and in good working order during the use of this jig.

OPERATION

This setup is intended to perform the cheek cuts of the tenon only. The cheek cuts are usually performed before the shoulder cuts, which are usually cut on a table saw using the miter gage.

⚠ WARNING

DISCONNECT SAW FROM THE POWER SOURCE.

Fig. 16

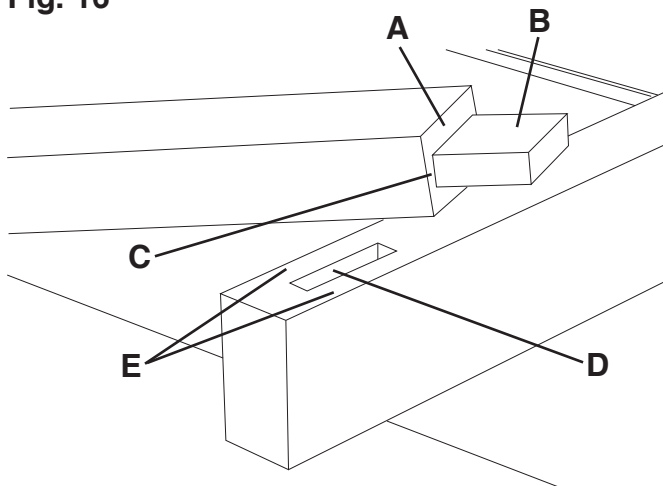

MORTISE AND TENON JOINT

Figure 16 illustrates the parts of a simple or blind mortise and tenon joint.

- | | |
|------------------------|------------------|
| A. Structural Shoulder | D. Mortise |
| B. Cheek | E. Mortise Walls |
| C. Cosmetic Shoulder | |

Start by laying out the mortise and tenon onto the workpiece. Keep the following items in consideration when laying out joints.

- To avoid premature joint failure, avoid locating a tenon in a disfigured part of the grain such as a knot, for unpredictable movement of the joint may occur. Always use straight, flat, common-grained stock.
- The tenon will shrink in width, away from the mortise walls, possibly revealing the mortise hole; therefore when possible, tenons should have shoulders on all four sides, two structural and two cosmetic, to conceal the mortised hole when wood movement occurs.
- The objective when making a mortise-and-tenon joint is to make the parts fit closely together, and maximize the gluing surface by making the tenon as long as possible, approximately 1/2 the width of the stile, or longer if using narrow stock. Balance the joint by making sure there is the same amount of wood in the tenon as there is in the combined thickness of the mortise walls. If your piece of wood is larger than the other, make the tenon as thick as possible.
- Remember to figure in the width of the saw blade when setting up for the cut.
- Cut all mortises first, making the mortise 1/16" deeper than the length of the tenon to allow for squeezed glue.

Fig. 17

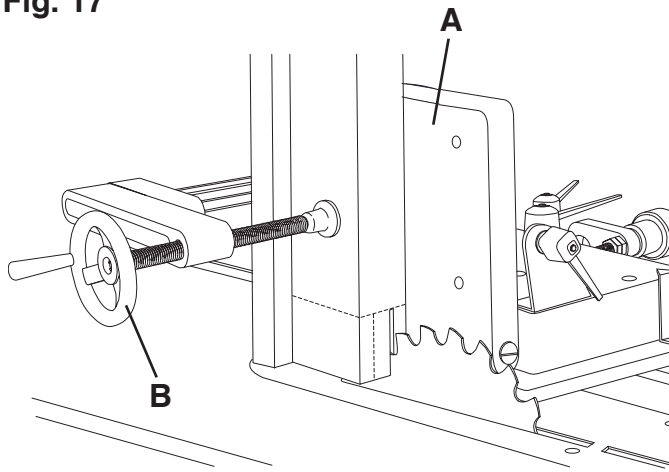

⚠ WARNING

Use of the Tenoning jig requires removal of the table saw's blade guard. After the Tenoning operation is complete, disconnect saw from power and reinstall the blade guard immediately.

Note: It is advisable to perform cuts on practice material first before cutting the good work piece.

1. Mark your board for the cheek cuts.
 2. Load your work piece in the tenoning jig against the vertical work support plate (A). Securely clamp the work piece in place by turning clamp handwheel (B). See Figure 17.
 3. Gently push Tenoning jig toward saw blade until work piece is near the saw blade. Adjust Tenoning jig and height of the saw blade so the first cheek cut can be made. Then return the jig to the front of the saw table.
 4. Connect saw to power source.
 5. Turn saw ON and perform the first cheek. Push the Tenoning jig toward the saw blade at a slow feed rate until the saw blade has exited out the back of the tenoning jig.
 6. Turn saw OFF.
- Note: Never pass the jig back over the moving saw blade. Wait until the power is off and the blade comes to a complete stop.
7. Loosen the clamp handwheel (B). Rotate the work piece 180-degrees. Make sure the alignment is correct and make the second cheek cut in the same manner as the first cut. See **Figure 17**.
 8. **Disconnect the saw from the power source.**

Note: If making cosmetic cheek cuts follow steps 9 through 13. If your tenon does not require cosmetic cheek cuts then go to cutting shoulders of tenon.

9. Loosen clamp handwheel (B) and rotate work piece 90-degrees and tighten handwheel. Make certain that the workpiece is properly secured and positioned in the jig. Align the Tenoning jig with the saw blade to make the cosmetic cheek cuts.
10. Connect saw to power source.
11. Make cut in the same manner as first and second cuts.
12. Turn saw OFF.
13. Loosen clamp handwheel (B) and turn workpiece 180-degrees and tighten clamp handwheel. Make certain that the workpiece is properly secured and positioned in the jig. Make sure alignment is correct and make fourth cut in same manner as previous cuts.
14. **Disconnect the saw from the power source.**

CUTTING SHOULDERS OF TENON

⚠ WARNING

DISCONNECT SAW FROM THE POWER SOURCE.

TO AVOID PERSONAL INJURY OR DAMAGE TO THE MACHINE, always use a cross-cut blade to perform the shoulder cuts of the tenon.

NOTE: It is advisable to perform cuts on practice material first before cutting the good workpiece.

1. Remove Tenoning Jig from the table saw.

Fig. 18

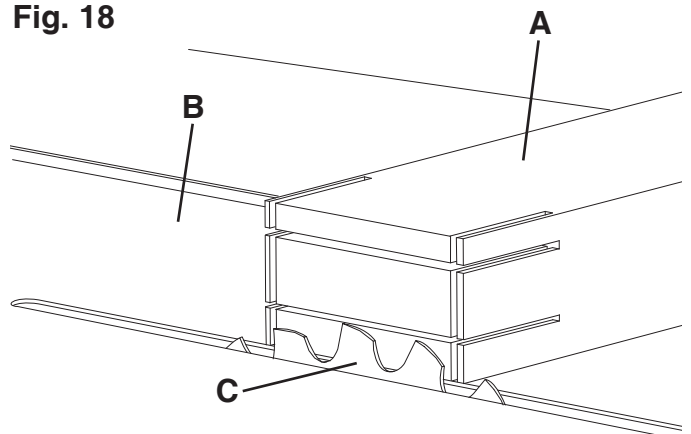

2. Lay the workpiece (A) onto the saw table (B) and adjust the saw blade (C) to the correct height to cut the structural shoulder of the tenon. **CAUTION:** Do not cut into the cheeks of the tenon, for it will greatly reduce the strength of the joint. See **Figure 18**.

⚠ WARNING

This jig should only be used with suitable tablesaws. Please refer to your tablesaw's manual for further information. All tablesaw safety features and guards must be kept in place and in good working order during the use of this jig.

Fig. 19

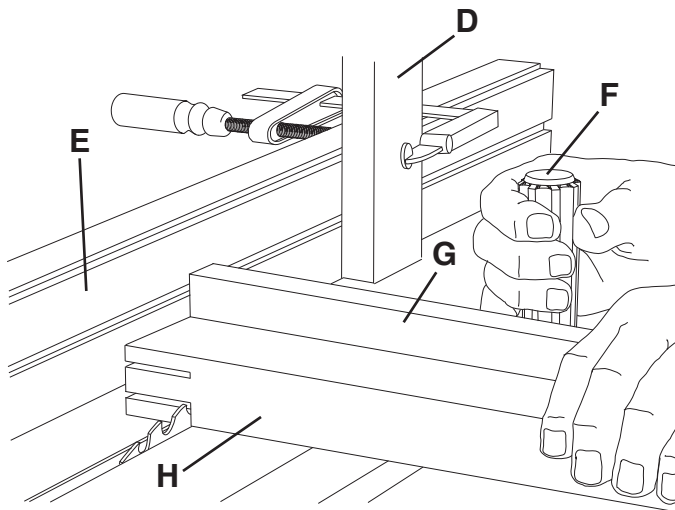

3. Clamp a wooden stop block (D) to the front of the saw fence (E). Adjust the saw fence to cut the structural shoulders of the tenon. Remember to figure in the width of the saw blade when adjusting the saw fence. See **Figure 19**.

⚠ WARNING

Always position the wooden stop block (D) to the front of the saw blade so the workpiece (H) cannot be trapped between the saw fence or stop block and the saw blade to avoid kickback. The piece of material being cut must be past the wooden stop block before contacting the saw blade.

4. Using a miter gage (F) equipped with a backup board (G), position the workpiece so the structural shoulders can be cut. See **Figure 19**. Make certain the workpiece is against the wooden stop block and the backup board.
5. **CONNECT SAW TO POWER SOURCE.**
6. Turn the saw on and perform the structural shoulder cut by slowly pushing the miter gage (F) toward the saw blade until the saw blade has exited out the rear of the miter gage. **TURN THE SAW OFF. AFTER THE BLADE HAS COME TO A COMPLETE STOP, REMOVE THE CUT-OFF SCRAP PIECE.** See **Figure 19**.
7. Return miter gage and turn the workpiece over to cut the second structural shoulder. Repeat steps 4, 5, and 6.
8. **DISCONNECT THE SAW FROM THE POWER SOURCE.**
9. Readjust the saw blade height to perform the cosmetic shoulder cuts.
10. **CONNECT SAW TO POWER SOURCE.**
11. Perform the cosmetic shoulder cuts in the same manner in which the structural shoulder cuts were made.
12. **DISCONNECT THE SAW FROM THE POWER SOURCE.**

⚠ WARNING

This jig should only be used with suitable tablesaws. Please refer to your tablesaw's manual for further information. All tablesaw safety features and guards must be kept in place and in good working order during the use of this jig.

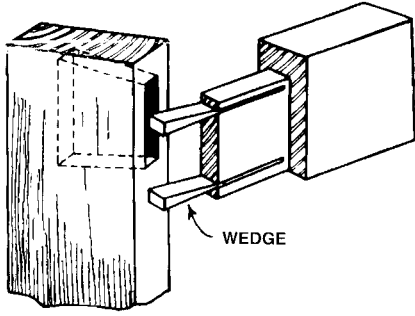

BLIND-WEDGED TENON

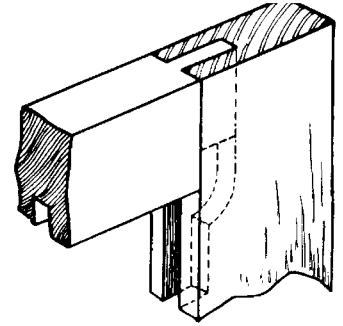
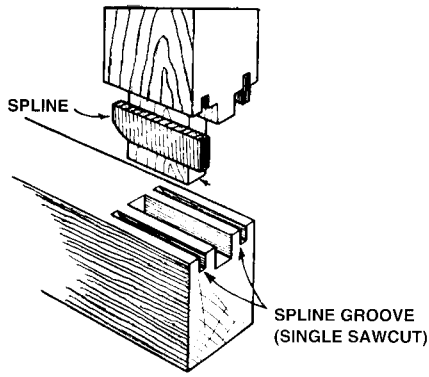

STUB TENON

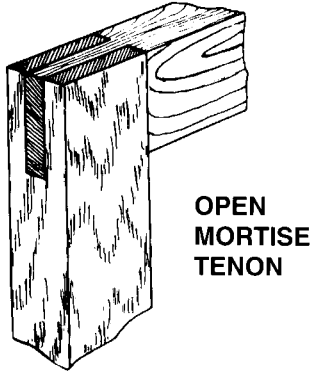

OPEN MORTISE TENON

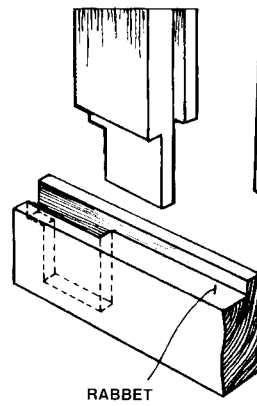

TENON WITH LONG AND SHORT SHOULDERS

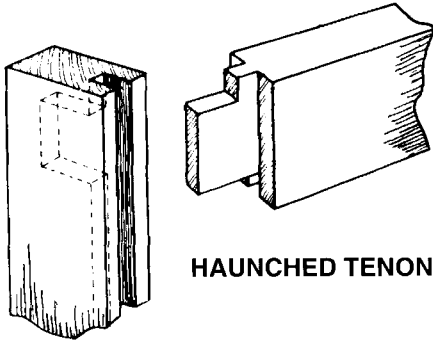

HAUNCHED TENON

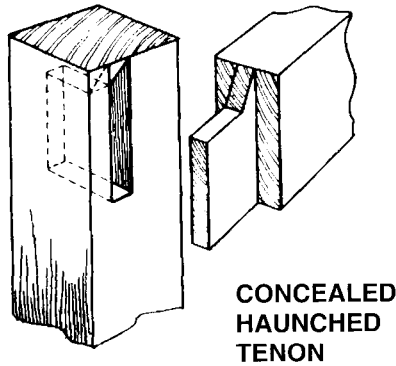

CONCEALED HAUNCHED TENON

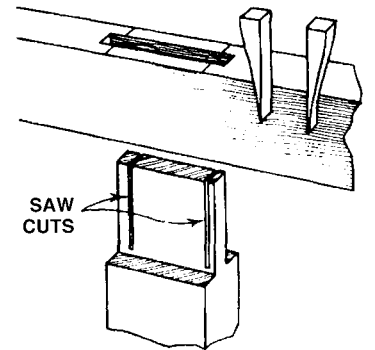

THROUGH-WEDGED TENON

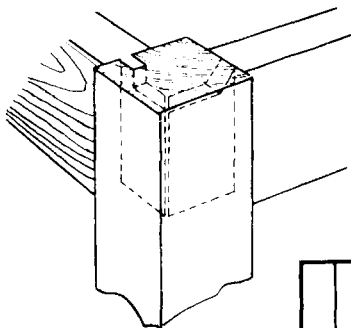

MITERED TENON

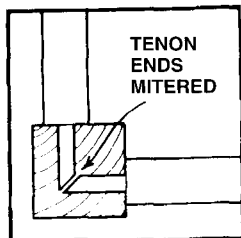

BARE FACED TENON

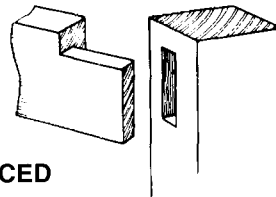

SIMPLE MORTISE AND TENON

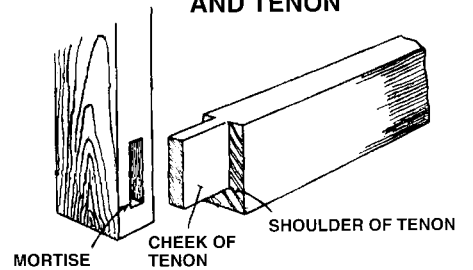

PARTS

TENONING JIG PARTS LIST

MODEL NO. CT084

WARNING

When servicing, use only manufacturer replacement parts. Use of any other parts may create a **HAZARD** or cause product damage.

This jig should only be used with suitable tablesaws. Please refer to your table saw's manual for further information. All table saw safety features and guards must be kept in place and in good working order during the use of this jig.

Always order by **PART NUMBER**, not by key number.

KEY NO.	DESCRIPTION	QTY.	KEY NO.	DESCRIPTION	QTY.
N/A	OWNER'S MANUAL (NOT SHOWN)	1	34A	SPECIAL SCREW	2
1	LOCK LEVER	1	34B	PLATE	2
2	M8.4 FLAT WASHER	1	34C	1/4-28 x 5/16" FLAT HEAD SCREW	2
3	M8 x 55MM STUD	1	35	HANDLE	1
4	LOCK LEVER	1	36	M10 x 25MM HEX SOCKET HEAD SCREW	1
5	M6.4 FLAT WASHER	1	36A	M10 x 20MM HEX SOCKET HEAD SCREW	1
6	LOCK BUSHING	1	37	M10.2 LOCK WASHER	2
7	HANDLE	1	38	CLAMP BRACKET	1
8	KNOB	1	39	WARNING LABEL	1
9	M3 x 20MM SPRING PIN	1	40	4MM DRIVE SCREW	2
10	BUSHING	1	41	3/8" x 2" SPRING PIN	1
11	BRACKET	1	42	CLAMP ARM	1
12	M6 x 10MM HEX SOCKET SET SCREW	1	43	M8 FLAT WASHER	1
13	NYLON WASHER	1	44	M8 x 50MM HEX SOCKET HEAD SCREW	1
14	M10 HEX LOW NUT	2	45	HAND WHEEL ASSEMBLY	1
15	SHAFT	1	46	SPECIAL SCREW M6 x 55MM	1
16	GUIDE BUSHING	1	47	M6 x 8MM HEX SOCKET SET SCREW	1
17	GUIDE ROD	1	48	CLAMP SCREW	1
18	M6 x 45MM HEX SOCKET SET SCREW	1	49	LOCK LEVER	1
19	M6 HEX LOW NUT	2	50	M6.4 FLAT WASHER	1
20	SLIDE	1	51	VERTICAL TABLE	1
21	SCALE	1	54	SPECIAL SCREW	2
22	M5 x 10MM PAN HEAD SCREW	2	55	M6 x 25MM HEX SOCKET SET SCREW	1
23	LOCK LEVER	1	56	M6.4 FLAT WASHER	1
24	M6.4 FLAT WASHER	1	57	STOP	1
25	BRACKET	1	57A	M5 HEX NUT	1
26	BUSHING	1	57B	M5 x 20MM HEX SOCKET SET SCREW	1
27	M8 HEX NUT	1	58	M6 SQUARE NUT	1
28	M4 x 8MM PAN HEAD SCREW	1	59	SPECIAL SCREW	1
29	POINTER	1	59A	M6.4 WAVE WASHER	1
30	M6 x 20MM BUTTON HEAD SCREW	2	65	3MM HEX WRENCH	1
31	M6.1 LOCK WASHER	2	66	4MM HEX WRENCH	1
32	BASE	1	67	6MM HEX WRENCH	1
33	M6 x 20MM HEX HEAD SCREW	2	68	8MM HEX WRENCH	1
34	GUIDE BAR	1	69	2.5MM HEX WRENCH	1

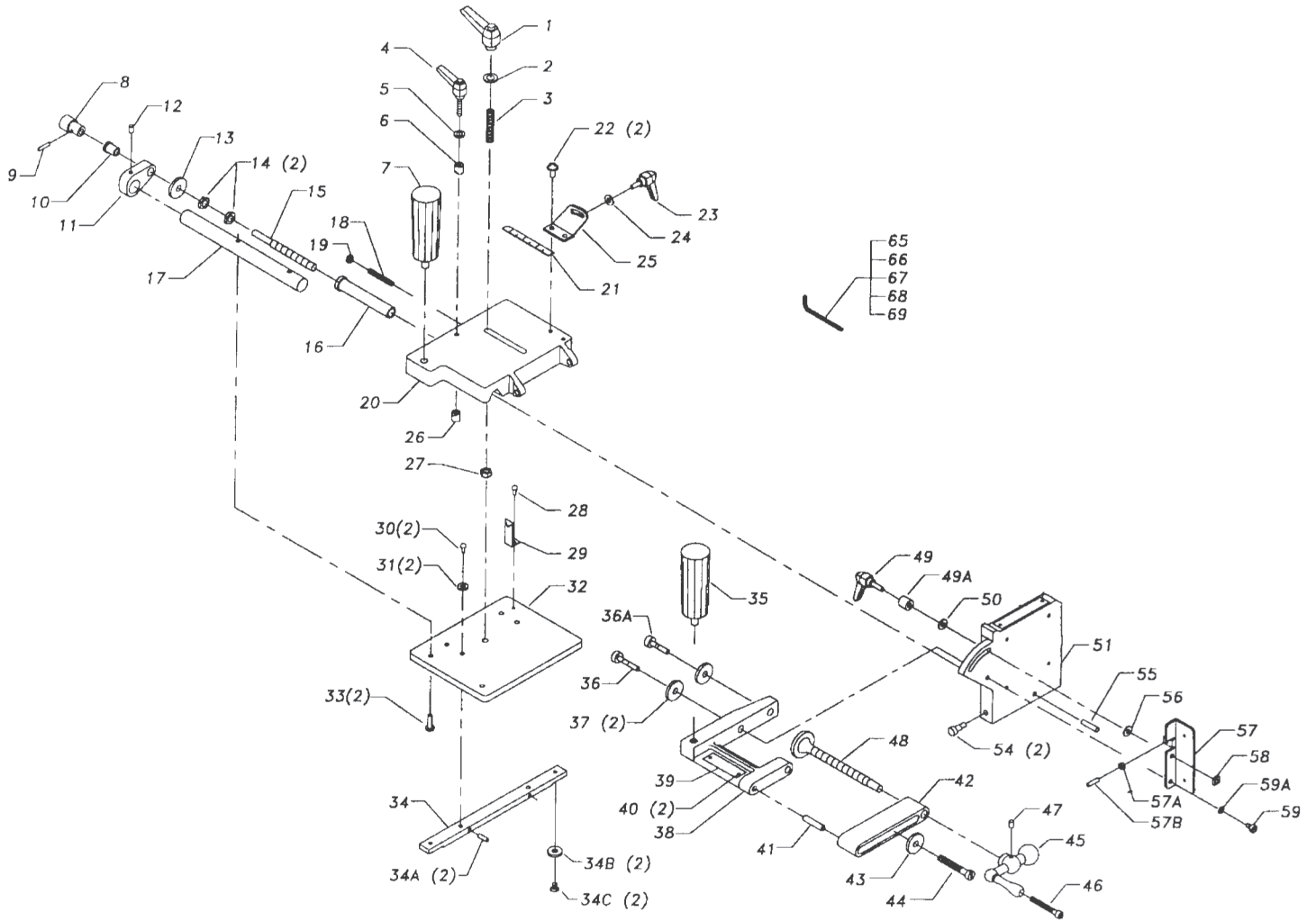

⚠ WARNING

This jig should only be used with suitable tablesaws. Please refer to your tablesaw's manual for further information. All tablesaw safety features and guards must be kept in place and in good working order during the use of this jig.

