



CT170N

1"x30" BELT & 5" DISC SANDER

User Manual



TABLE OF CONTENTS

General Safety Instructions for Machines	3
Specific Safety Instructions	4
CT170N Features	5
Physical Features	6
Proper Grounding	7
Un-Packing	8
Sanding Belt Table.....	8
Dust Chute.....	8
Sanding Disc Table.....	9
Belt Tracking.....	9
Upper Guard	10
Test Run	11
Belt Sander Platen.....	11
Squaring the Table.....	11
Sanding Belt Replacement	12
Sanding Disc Replacement.....	13
Miter Gauge	13
Maintenance	13
Parts Diagram.....	14
Parts List.....	15
Warranty	17

GENERAL SAFETY INSTRUCTIONS FOR MACHINES

Extreme caution should be used when operating all power tools. Know your power tool, be familiar with its operation, read through the owner's manual and practice safe usage procedures at all times.

- ❖ **ALWAYS** read and understand the user manual before operating the machine.
- ❖ **CONNECT** your machine ONLY to the matched and specific power source.
- ❖ **ALWAYS** wear safety glasses respirators, hearing protection and safety shoes, when operating your machine.
- ❖ **DO NOT** wear loose clothing or jewelry when operating your machine. Wear protective hair covering.
- ❖ **A SAFE ENVIRONMENT** is important. Keep the area free of dust, dirt and other debris in the immediate vicinity of your machine.
- ❖ **BE ALERT! DO NOT** use prescription or other drugs that may affect your ability or judgment to safely use your machine.
- ❖ **DISCONNECT** the power source when changing drill bits, hollow chisels, router bits, shaper heads, blades, knives or making other adjustments or repairs.
- ❖ **NEVER** leave a tool unattended while it is in operation.
- ❖ **NEVER** allow unsupervised or untrained personnel to operate the machine
- ❖ **NEVER** reach over the table when the tool is in operation.
- ❖ **ALWAYS** keep blades, knives and bits sharpened and properly aligned.
- ❖ **ALL OPERATIONS MUST BE** performed with the guards in place to ensure safety.
- ❖ **ALWAYS** use push sticks and feather boards to safely feed your work through the machine.
- ❖ **ALWAYS** make sure that any tools used for adjustments are removed before operating the machine.
- ❖ **ALWAYS** keep bystanders safely away while the machine is in operation.
- ❖ **NEVER** attempt to remove jammed cutoff pieces until the blade has come to a full stop.

CT170N – 1”x30” BELT & 5” DISC SANDER

SPECIFIC SAFETY INSTRUCTIONS

- ⚠ **MAKE SURE** the sander is connected to the matched and specific power source.
- ⚠ **ALL THE GUARDS** must be in place while operating the sander to ensure operator safety.
- ⚠ **MAKE SURE** before making any adjustments, the switch is in the “OFF” position and the cord is un-plugged from the power source.
- ⚠ **NEVER** sand more than one work piece at a time.
- ⚠ **DO NOT** wear loose clothing while operating this sander.
- ⚠ **KEEP YOUR WORK AREA CLEAN.** Cluttered areas and workbenches increase the chance of accidents.
- ⚠ **NEVER LEAVE** the sander unattended while it is running.
- ⚠ **KEEP CHILDREN AWAY.** All visitors should be kept at a safe distance from the work area.
- ⚠ **DO NOT** force the sander. It will do the job better and will be safer at the operating rate for which it is designed.
- ⚠ **ALWAYS** wear a dust mask and safety glasses while operating the sander. The tiny dust particles produced by the sander can cause serious health problems.
- ⚠ **ALWAYS** inspect the work-piece for staples, nails knots or any other foreign material before sanding.
- ⚠ **ALWAYS** operate the sander in a well-ventilated area and use a dust collection system for dust removal whenever possible.
- ⚠ **ALWAYS** hold the work piece firmly when sanding. When not using the table, i.e. sanding free-hand, grip the work piece with both hands.
- ⚠ **USE THE STOP FENCE** when performing horizontal sanding on the belt sander.
- ⚠ **MAINTAIN AND SERVICE** your sander regularly as instructed in this user manual.
- ⚠ **MAKE SURE** you have read and understood all the safety instructions in this manual and that you are familiar with your CT170N sander, before operating. If you fail to do so, serious injury could occur.

WARNING!

The safety instructions given above can not be complete because the environment in every shop is different. Always consider safety first as it applies to your individual working conditions.



CT170N – BELT & DISC SANDER

FEATURES

MODEL CT170N – 1”x30” BELT & 5” DISC SANDER

As part of the growing line of Craftex woodworking equipment, we are proud to offer the CT170N, a 1” x 30” Belt and 5” Disc Sander. By following the instructions and procedures laid out in this user manual, you will receive years of excellent service and satisfaction. The C170N is a professional tool and like all power tools, proper care and safety procedures should be adhered to.

- ❖ Motor Type Induction
- ❖ Motor Ratings 1/3-HP, 120-Volts, 60-Hz
- ❖ No Load Speed..... 3450 RPM
- ❖ Amps 2.3
- ❖ Sanding Disc Diameter..... 5”
- ❖ Sanding Disc Grit..... 80
- ❖ Sanding Belt Size Length 30” x Width 1”
- ❖ Sanding Belt Grit A 100
- ❖ Dust Port..... Two 1-3/4” Dust Ports
- ❖ Weigh 16 lbs
- ❖ Warranty..... 2 Years

CT170N – 1"X30" BELT & 5" DISC SANDER PHYSICAL FEATURES

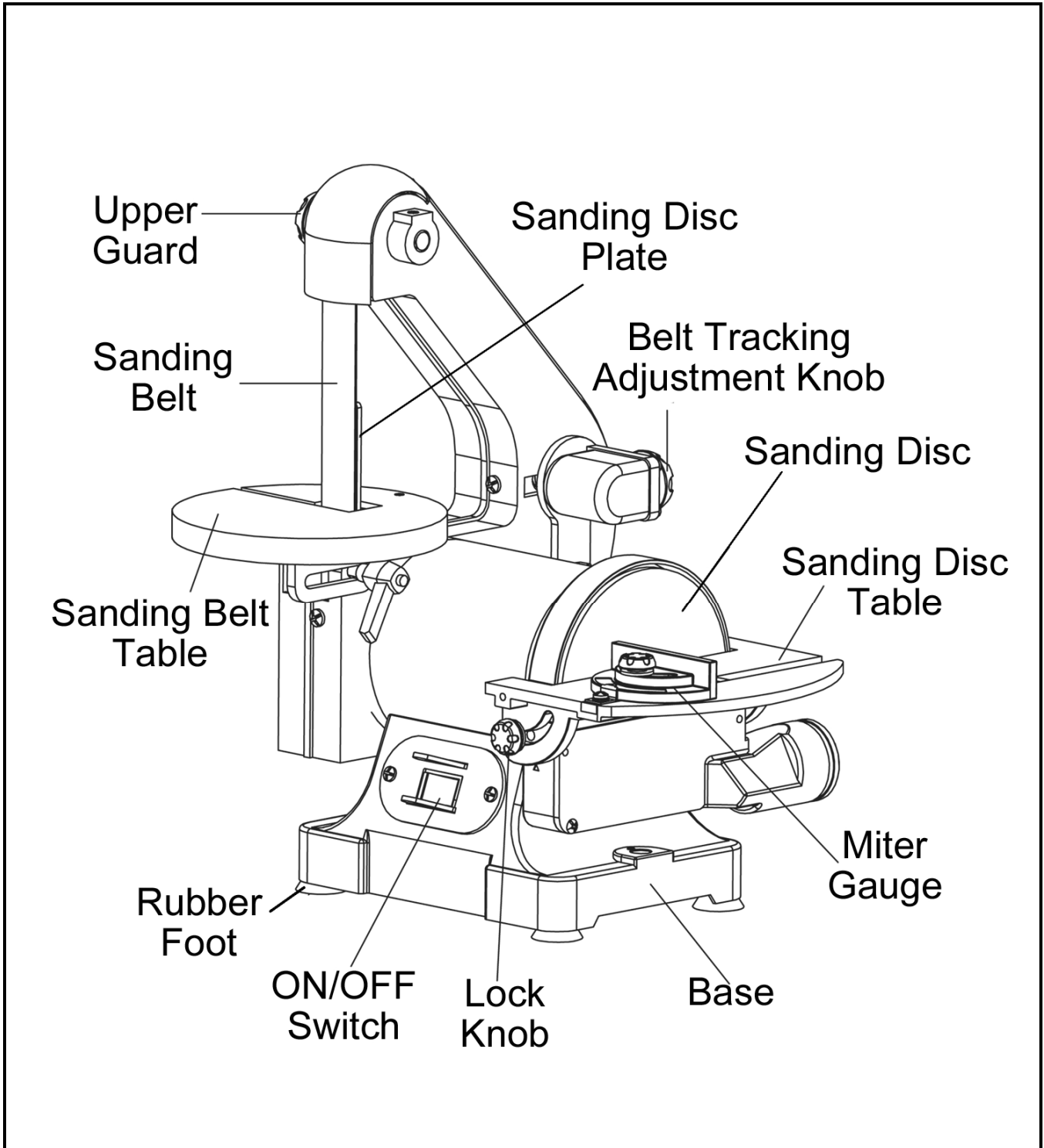

PROPER GROUNDING

Grounding provides a path of least resistance for electric current to reduce the risk of electric shock.

Make sure the cord is plugged into a properly installed and grounded power outlet. To prevent electrical hazards, have a qualified electrician ensure that the line is properly wired.

Make sure that the appliance is connected to an outlet having the same configuration as the plug. If an adaptor plug is used, it must be attached to the metal screw of the receptacle.

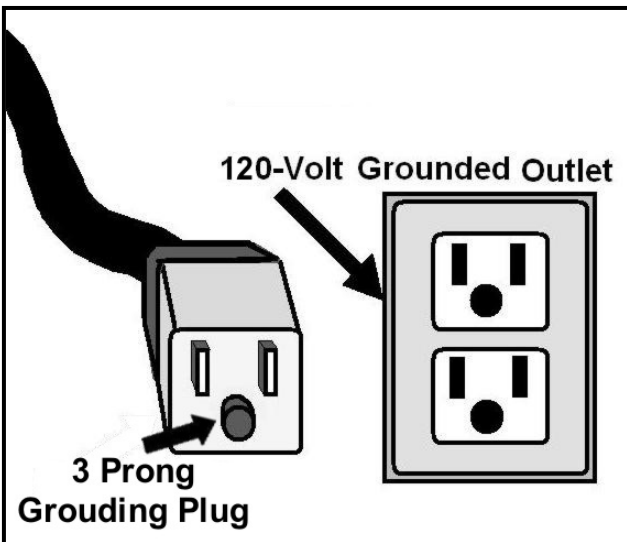

Figure-1 120-Volts outlet for CT170N

It is strongly recommended not to use extension cords with your CT170N. Always try to position your machine close to the power source so that you do not need to use extension cords.

In case if you really find it necessary to use an extension cord, make sure the extension cord does not exceed 50-feet in length and the cord is 14-gauge to prevent motor damage.

WARNING!

Improper connection of the equipment-grounding conductor can result in a risk of electric shock. Check with a qualified electrician if you are in doubt as to whether the outlet is properly grounded.

UNPACKING

The machine is properly packaged and shipped in a carton for safe transportation. When unpacking, carefully inspect the carton to ensure that nothing has been damaged and check that the sander and the parts are in good condition.

While doing inventory, if you can not find any part, check if the part is already installed on the machine. Some of the parts come preassembled on the machine.

SANDING BELT TABLE

The CT170N is equipped with a tilting table secured by a lock lever.

To install the table:

Make sure the switch is in the OFF position and the cord is disconnected from the power source.

Pass the sanding belt through the slot on the table and position the table on the machine as shown in figure-2.

Secure the table to the machine using the lock lever. See figure-2.

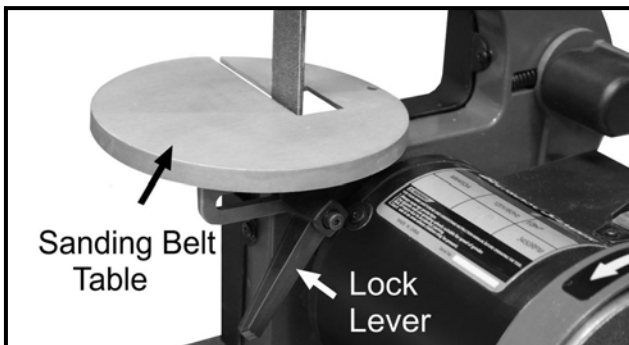

Figure-2 Installing the sanding belt table

DUST PORT

For optimum dust removal the sander is equipped with two dust ports.

The sanding belt dust port with the side guard is mounted to the machine using a lock knob and two screws. See figure-3.

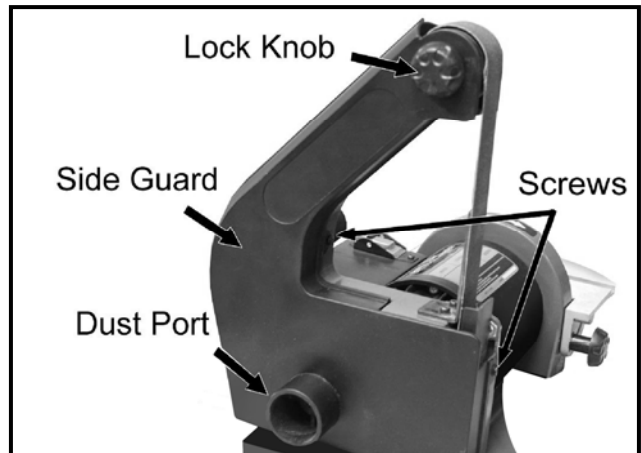

Figure-3 Sanding belt dust port with side guard

The sanding disc is also provided with a dust port to remove the dust created while using the disc.

To install the dust chute:

Make sure the switch is in the OFF position and the cord is disconnected from the power source.

Attach the dust port to the sander as shown in figure-4 and secure it using screws and washers provided.

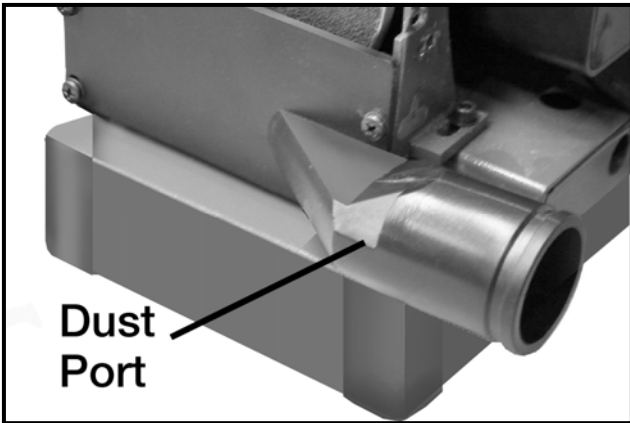

Figure-4 Installing sanding disc dust port

SANDING DISC TABLE

CT170N is provided with a work table for disc sanding operation.

To install the sanding disc table:

Make sure the switch is in the OFF position and the cord is disconnected from the power source.

Attach the table to the sander, above the dust chute as shown in figure-5 and secure it using two lock knobs from both sides.

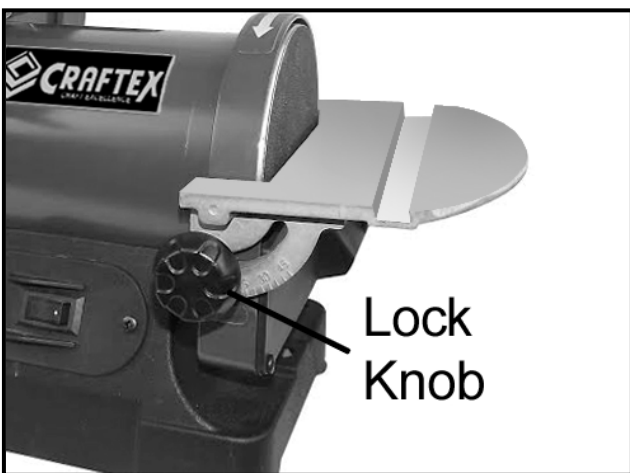

Figure-5 Installing the sanding disc table

BELT TRACKING

Belt tracking means to adjust the belt in the center of the rollers so that it runs true and does not wander left or right off the rollers.

The belt tracking adjustment on CT170N is very simple and easy. The sander is provided with a belt tracking adjustment knob as shown in figure-6.

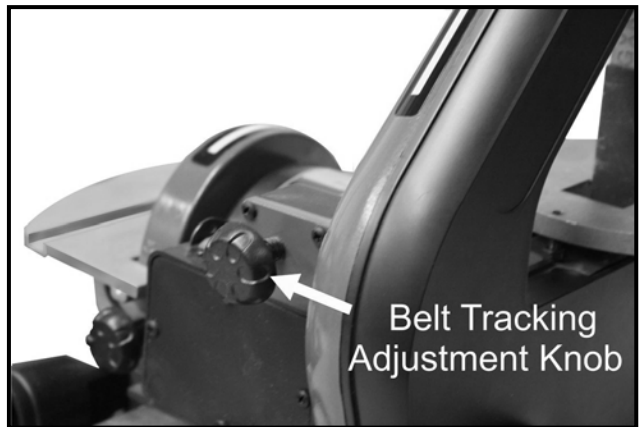

Figure-6 Belt Tracking adjustment knob

To adjust the belt tracking:

Make sure the switch is in the OFF position and the cord is disconnected from the power source.

Remove the upper guard lock knob, the screws holding the side cover and remove the side cover to expose the rollers.

Rotate the sanding disc with your hand which will rotate the sanding belt and watch where the belt rides on the rollers.

Keep rotating the disc with one hand the use the other hand to turn the belt tracking adjustment knob.

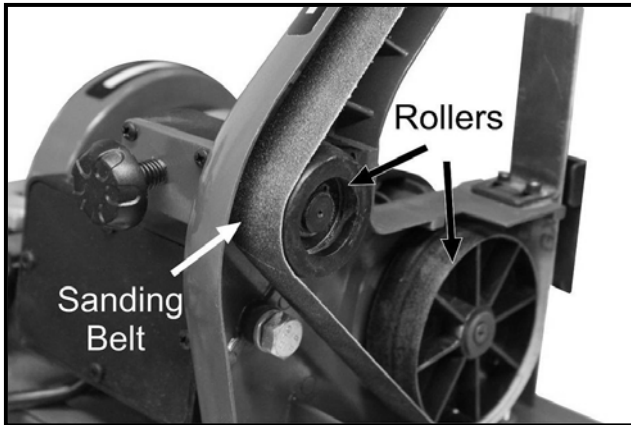

Figure-7 Adjusting the belt tracking

Once the belt is in the center of the rollers, stop turning the adjustment knob and the disc.

Re-install the side cover and connect the cord to the power source.

Turn the sander ON and then quickly OFF and watch if the belt is riding true in the center of the rollers.

UPPER GUARD

Install the upper bracket to the belt sanding arm and secure it with the lock knob as shown in figure-8.

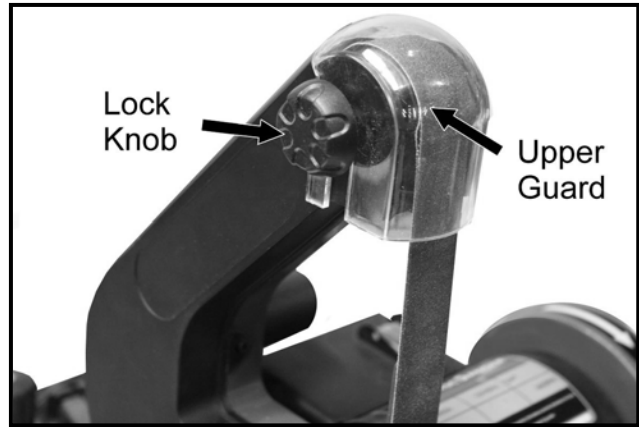

Figure-8 Installing the upper guard

TEST RUN

Once you have assembled the machine it is then time to do a test run and see that the machine powers up and runs properly.

All the tools and objects used for assembling the machine should be removed and cleared away during test run.

During the test run make sure the ON/OFF switch and all the safety features on the machine are working properly.

Connect the machine to the correct power source. Stand to the side of the sander and start the machine. During the test run if there is any unusual noise or vibration, disconnect the machine from the power source immediately. Check all the parts you have assembled, once again and try to find out the problem.

BELT SANDER PLATEN

The platen is a steel support plate that is positioned behind the sanding belt, rising from the table level to a point several inches above the table surface. The platen provides support to the work when sanding and it should be adjusted so that it is almost touching the back of the sanding belt.

To adjust the platen:

Make sure the switch is in the OFF position and the cord is disconnected from the power source.

Loosen the lever securing the table and remove it to access the hex screws.

Loosen the two hex screws securing the platen to the sander frame.

Adjust the platen so that it is almost touching the back of the belt and re-tighten the screws. See figure-9.

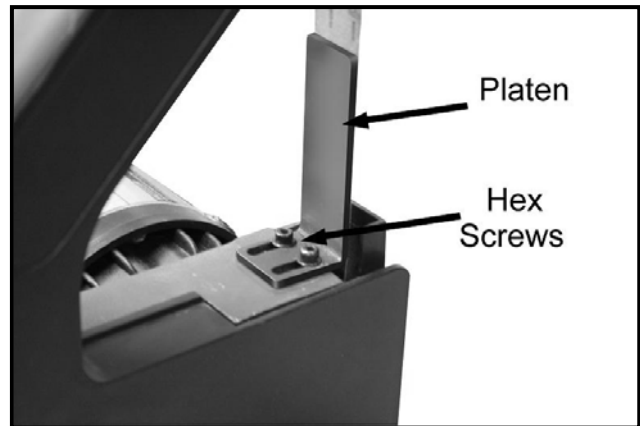

Figure-9 Sanding platen

SQUARING THE TABLES

A better result can be attained when the table is at 90° with the belt/disc.

To square the table:

Make sure the switch is in the OFF position and the cord is disconnected from the power source.

Loosen the lock knobs/lever securing the table to the machine and place a square on the table as shown in figure-10 and figure-11.

Adjust the table so that it is square with the belt/disc and tighten the knobs.



Figure-10 Squaring table to the belt

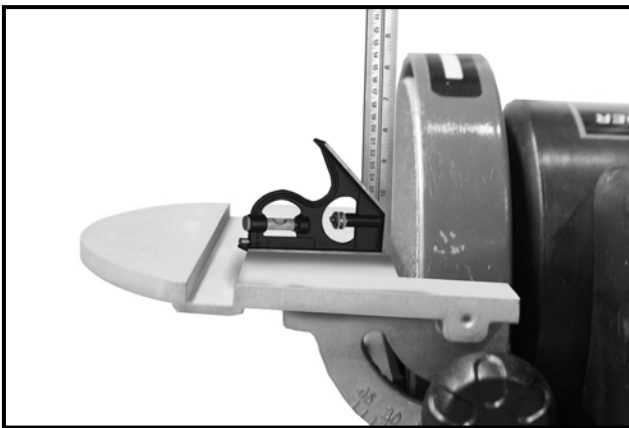

Figure-11 Squaring table to the disc

SANDING BELT REPLACEMENT

To replace the sanding belt:

Make sure the switch is in the OFF position and the cord is disconnected from the power source.

Remove the upper guard and the side cover by removing the lock knob and loosening the two screws securing the

upper guard and the side cover. See figure-

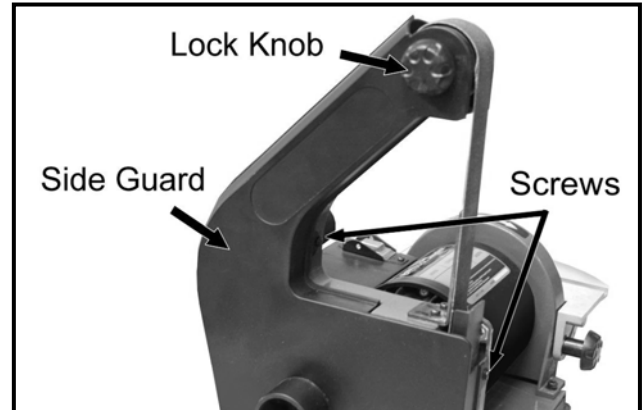

12.

Figure-12 Removing the side cover

The middle roller features spring at the back and can be pushed towards the table.

To remove the belt, hold the adjusting shaft guard and apply moderate pressure just to loosen the belt tension and push it towards the table. See figure-14.

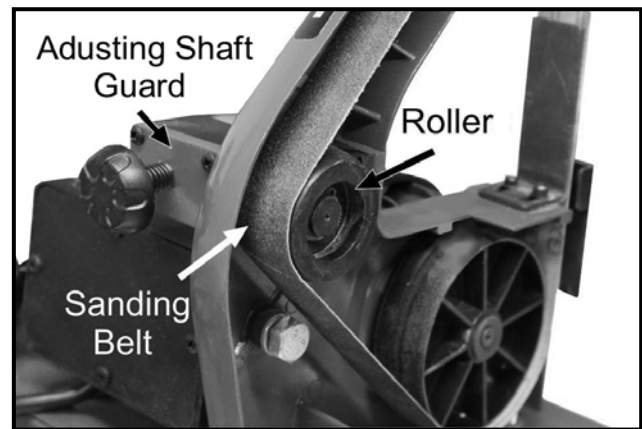

Figure-13 Replacing the belt

Take the belt off the rollers with the other hand and replace it with a new one.

Once the belt is positioned on the wheels, remove your hand and let the adjusting shaft guard to come in its normal position and tension the belt.

Perform the belt tracking adjustment and re-install the cover and the table.

SANDING DISC REPLACEMENT

To replace the sanding disc:

Turn the switch OFF and remove the cord from the power source.

Loosen the sanding disc table and the dust chute by removing the knobs and screws securing them to the sander.

Peel the old sanding disc from the sanding wheel and clean the surface of the wheel.

Peel off the back of the new sanding disc and expose its self adhesive back and position it on the wheel. Make sure it is on the center of the wheel. See figure-14.

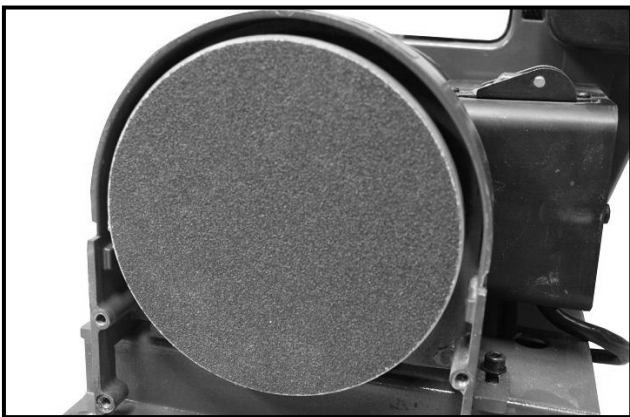

Figure-14 Installing sanding disc

MITER GAUGE

CT170N is provided with a miter gauge and can be used on the disc table.

The miter gauge head can be set anywhere up to 45° right or left, by loosening the lock knob, setting the miter gauge ahead to the desired angle and tightening the lock knob.

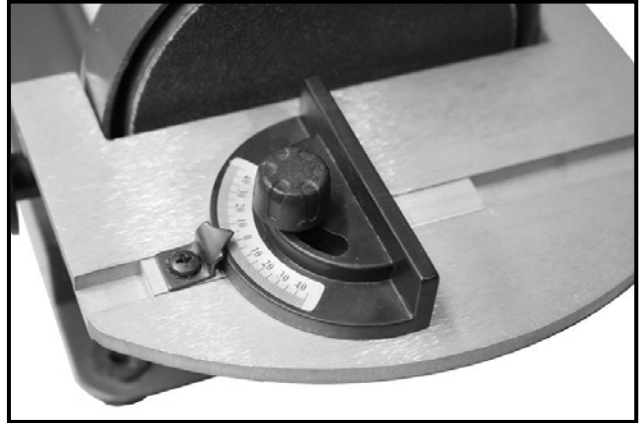

Figure-15 Miter gauge

WARNING!

Turn the switch OFF and make sure the cord is disconnected from the power source before installing, servicing, removing any parts. Failure to do so may result serious personal injury.

MAINTENANCE

All ball bearings are sealed and permanently lubricated and do not require any lubrication.

Check the sander for loose mounting hardware, worn or damaged wires, damaged abrasive belt and disc or any other unsafe condition before each use.

CT170N Parts Diagram

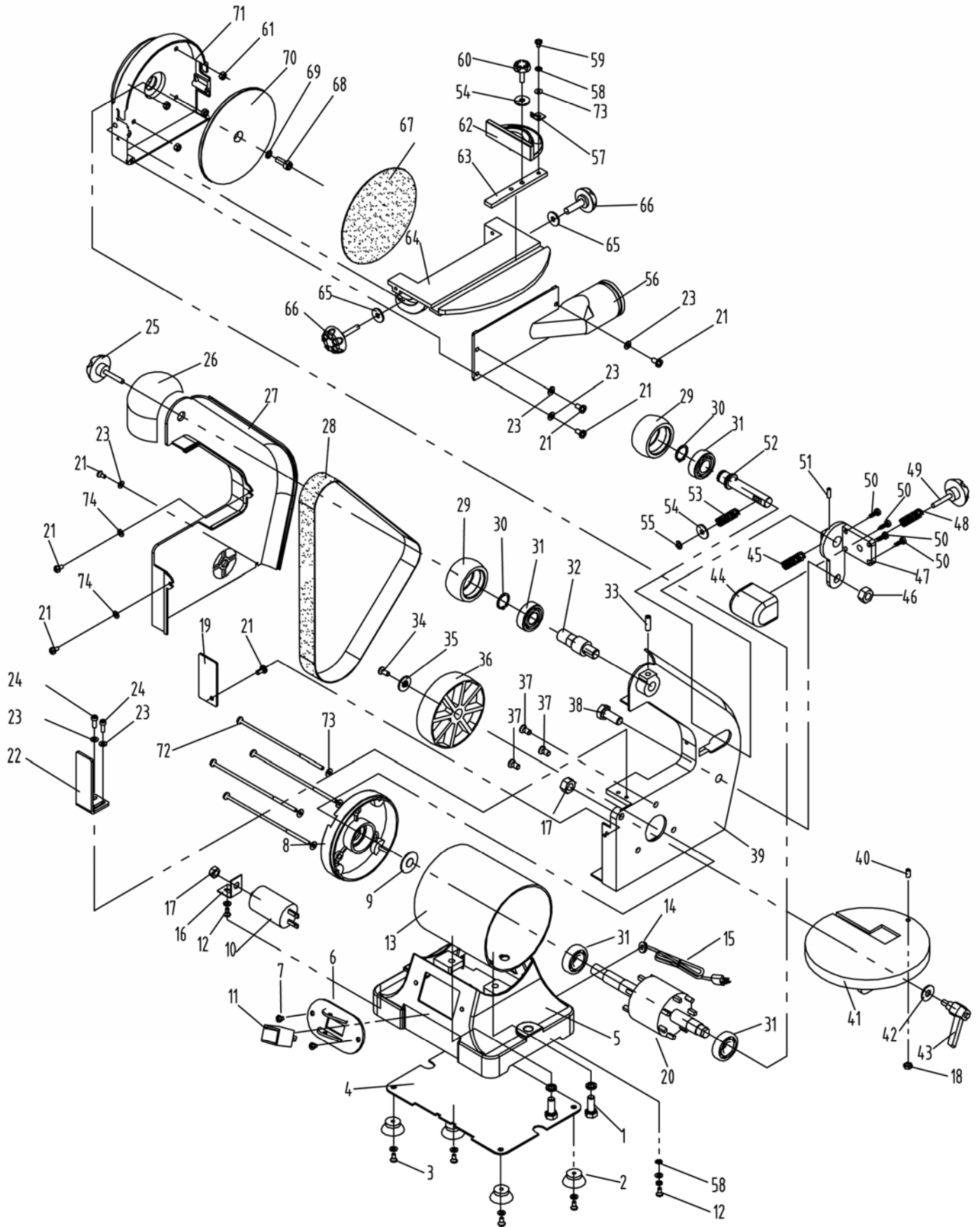

CT170N PARTS LIST

NO	DESCRIPTION	SPEC	QTY	NO	DESCRIPTION	SPEC	QTY
1	Philips screw +flat washer assy	M6x18	2	30	Spring washer	D15	2
2	Rubber foot		4	31	Bearing	6202	4
3	Philips screw +flat washer assy	M4x12	4	32	Idler shaft		1
4	Base plate		1	33	Hex screw	M6x8	1
5	Base		1	34	Philips screw	M5x16 Left	1
6	Switch Plate		1	35	Locking washer		1
7	Philips screw	M5x10	2	36	Driving wheel		1
8	Ends Caps		1	37	Philips screw	M6x10	3
9	Wavy Washer	35	1	38	Hex Bolt	M10x25	1
10	Capacitor		1	39	Sanding Belt support		1
11	Switch		1	40	Hex screw	M6x20	1
12	Philips screw +flat washer Assembly	M4x8	2	41	Belt Working table		1
13	Stator		1	42	Big flat washer	D8	1
14	Cord Clip		1	43	Locking knob assy		1
15	Cord & Plug		1	44	Adjusting shaft guard		1
16	Capacitor Support		1	45	Adjusting spring		1
17	Hex Nut	M8	2	46	Nut	M10	1
18	Hex Nut	M6	1	47	Adjusting fixing plate		1
19	Belt Guard plate		1	48	Adjusting spring I		1
20	Rotor		1				
21	Philips screw	M4x10	7				
22	Sanding Belt limiting plate		1				
23	Flat washer	D4	6				
24	Hex screw	M4x10	2				
25	Locking knob		1				
26	Belt guard		1				
27	Belt support cover		1				
28	Belt 100#	1"x30"	1				
29	Idler wheel		2				

NO	DESCRIPTION	SPEC	QTY
49	Adjusting knob		1
50	Philips screw	ST4.2x10	4
51	Spring Column Pin	φ3x20	1
52	Adjusting shaft		1
53	Adjusting spring II		1
54	Big flat washer	D5	2
55	Split washer	3.5	1
56	Sanding Disc Cover		1
57	Pointing Arrow		1
58	Outer tooth locking washer	D4	2
59	Philips screw	M4x6	1
60	Mitre Gauge Handle		1
61	Hex knob	M4	4
62	Mitre Gauge		1
63	Rod		1
64	Disc Table		1
65	Flat washer	D6	2
66	Table locking knob		2
67	Disc Paper 80#	5"	1
68	Hex screw	M6x16	1
69	Outer tooth locking washer	D6	1
70	Disc		1
71	Disc safeguard		1
72	Philips screw	M4x155	4
73	Flat washer	D4	5
74	Big flat washer	D4	2



WARRANTY

CRAFTEX 2 YEARS LIMITED WARRANTY

Craftex warrants every product to be free from defects in materials and agrees to correct such defects where applicable. This warranty covers **two years** for parts and 90 days for labor (unless specified otherwise), to the original purchaser from the date of purchase but does not apply to malfunctions arising directly or indirectly from misuse, abuse, improper installation or assembly, negligence, accidents, repairs or alterations or lack of maintenance.

Proof of purchase is necessary.

All warranty claims are subject to inspection of such products or part thereof and Craftex reserves the right to inspect any returned item before a refund or replacement may be issued.

This warranty shall not apply to consumable products such as blades, bits, belts, cutters, chisels, punches etceteras.

Craftex shall in no event be liable for injuries, accidental or otherwise, death to persons or damage to property or for incidental contingent, special or consequential damages arising from the use of our products.

RETURNS, REPAIRS AND REPLACEMENTS

To return, repair, or replace a Craftex product, you must visit the appropriate Busy Bee Tools showroom or call 1-800-461-BUSY. Craftex is a brand of equipment that is exclusive to Busy Bee Tools.

For replacement parts directly from Busy Bee Tools, for this machine, please call 1-800-461-BUSY (2879), and have your credit card and part number handy.

- All returned merchandise will be subject to a minimum charge of 15% for re-stocking and handling with the following qualifications.
- Returns must be pre-authorized by us in writing.
- We do not accept *collect* shipments.
- Items returned for warranty purposes must be insured and shipped pre-paid to the nearest warehouse
- Returns must be accompanied with a copy of your original invoice as proof of purchase. Returns must be in an un-used condition and shipped in their original packaging a letter explaining your reason for the return. Incurred shipping and handling charges are not refundable.
- Busy Bee will repair or replace the item at our discretion and subject to our inspection.
- Repaired or replaced items will be returned to you pre-paid by our choice of carriers.
- Busy Bee reserves the right to refuse reimbursement or repairs or replacement if a third party without our prior authorization has carried out repairs to the item.
- Repairs made by Busy Bee are warranted for 30 days on parts and labour.
- Any unforeseen repair charges will be reported to you for acceptance prior to making the repairs.
- The Busy Bee Parts & Service Departments are fully equipped to do repairs on all products purchased from us with the exception of some products that require the return to their authorized repair depots. A Busy Bee representative will provide you with the necessary information to have this done.
- For faster service it is advisable to contact the nearest Busy Bee location for parts availability prior to bringing your product in for repairs.

