

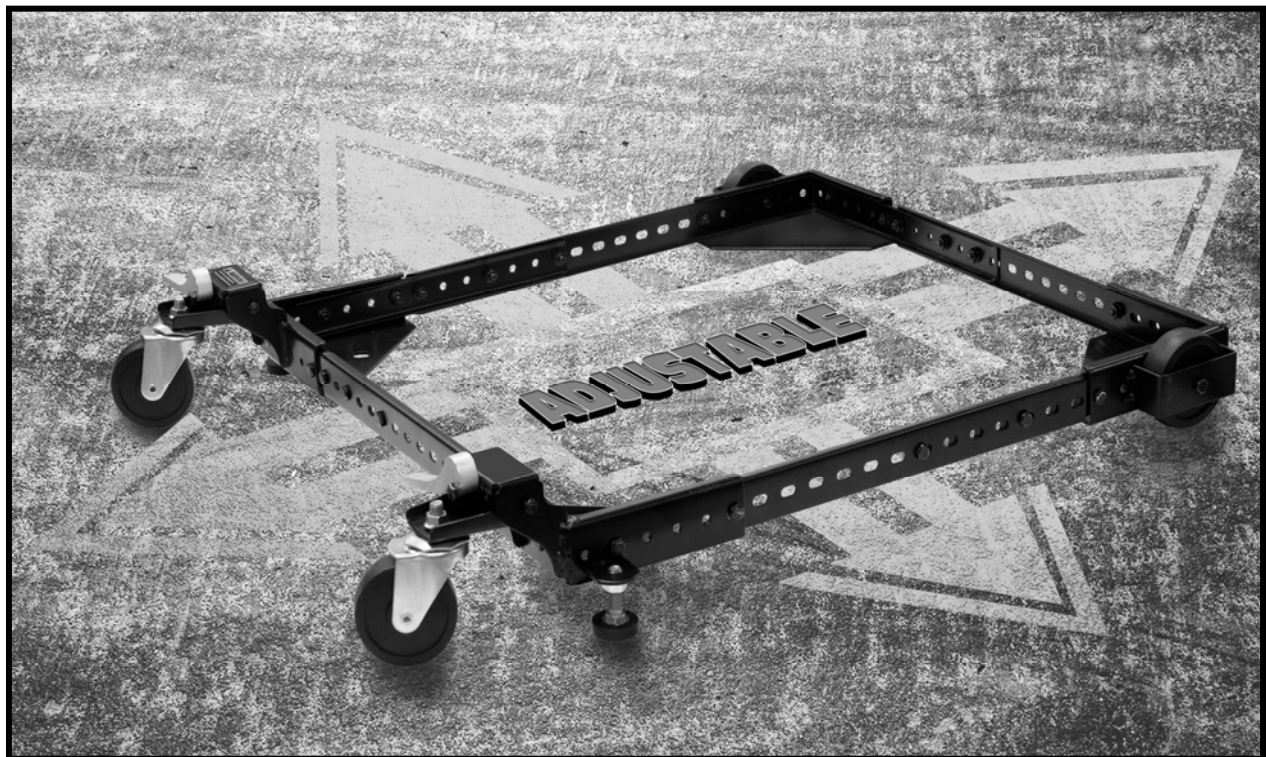

CT183/CT184 UNIVERSAL MOBILE BASE INSTRUCTIONS MANUAL



SAFETY INSTRUCTIONS

Do not position a machine heavier than (450 lbs on CT183) & (500 lbs on CT184) mobile base.

When adjusting the side rails for bigger/smaller machines, make sure the nuts and bolts are tightened properly.

Place the mobile base on a levelled surface and adjust the levelling feet before positioning the machine on the mobile base.

Always lower the mobile base onto the levellers before operating the machine.

Always test your setup for stability before moving or repositioning the machine.

Never use the machine without engaging the wheel locks on the mobile base.

Always unplug the cord from the power source before moving the machine.

ASSEMBLY

Follow the instructions given below to assemble your mobile base.

Measure the foot print of your machine or whatever you want to position on the mobile base and add 1" to the dimension to allow clearance for the fasteners.

Select the side rails and arrange them to assemble the mobile base to the footprint of your machine.

Check the assembly examples below and arrange the side rails according to the foot print of your machine.

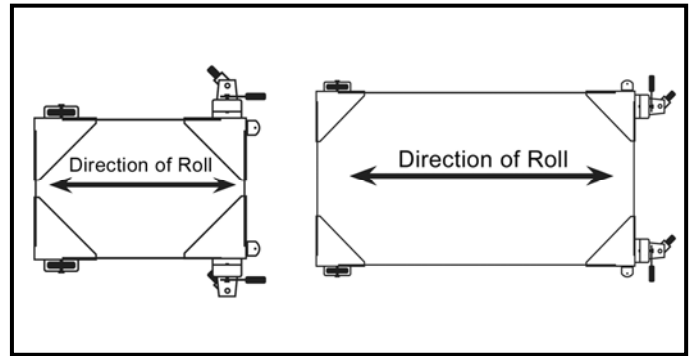

Figure-1 Mobile base assembly examples to fit different machines base

Bolt the side rails to the corners as far as possible and then to each other using proper sized nuts and bolts provided. Do not tighten the nuts and bolts at this time.

Re-check the dimensions with the foot print of the machine and tighten all the nuts and bolts.

ATTACHING THE CASTERS

Attach the swivel bracket to the corner bracket using the pivot rod bolt and a 1/4" self locking nut. See figure-2.

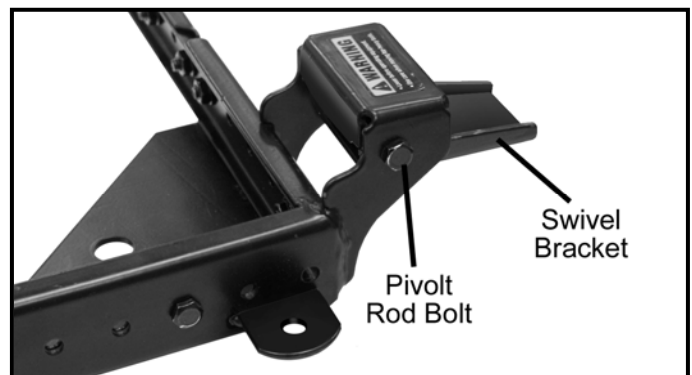

Figure-2 Installing the swivel bracket

Attach the lock lever to the corner and the swivel brackets, shown in figure-3 using a pivot bolt.

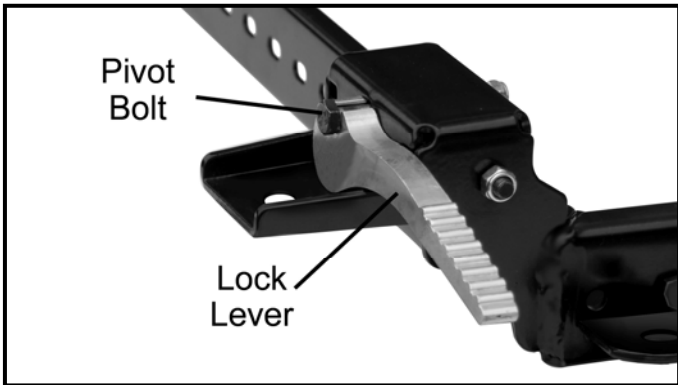

Figure-3 Installing the foot operated lock lever

Now, attach the swivel caster to the swivel bracket using a nut. See figure-4.

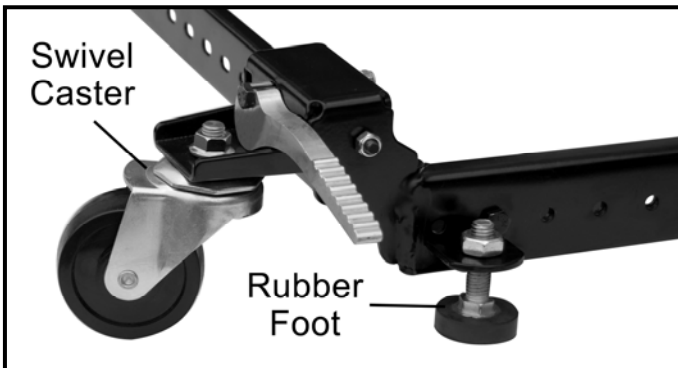

Figure-4 Installing the swivel caster and the rubber foot

Insert the threaded rubber foot into the threaded hole in levelling foot bracket and thread the nut onto the rubber foot bolt. See figure-4.

Attach the fixed wheel to the mobile base using a bolt and a nut shown in figure-5.

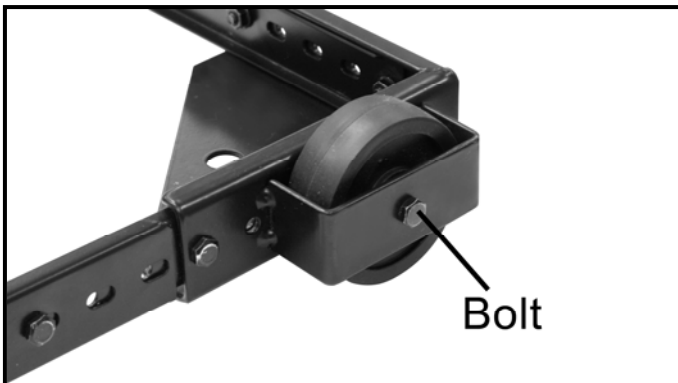

Figure-5 Installing the fixed wheel

Repeat the above steps to install the second swivel bracket, caster and fixed wheel on the other side of the mobile base.

CAUTION!

Check stability of the mobile base in the up and down positions before using. Failure to follow safety instructions may result in serious personal injury or damage to the tool.

WARNING!

The safety instructions given in this manual can not be complete because the environment in every shop is different. Always consider safety first as it applies to your individual working conditions.

CT183/CT184 PARTS DIAGRAM AND LIST

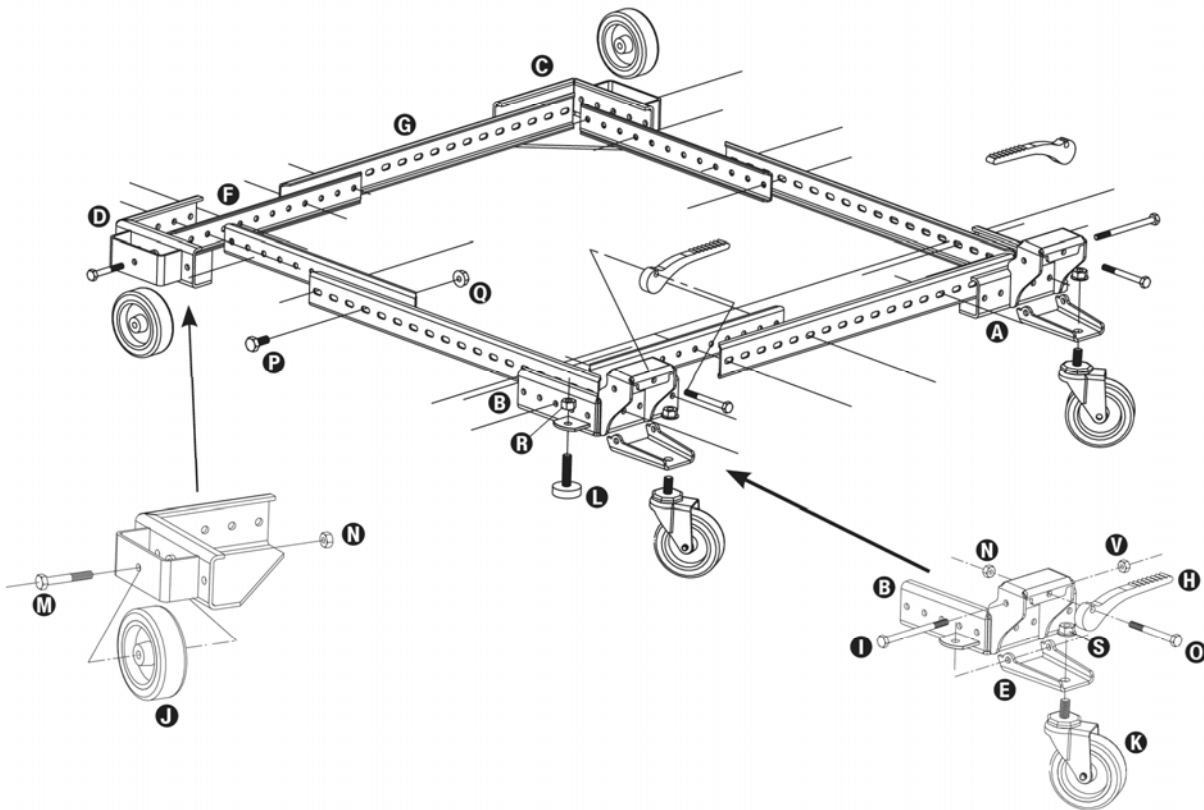

Description	Part Number	Qty
A Corner (Front-Right)	3057	1
B Corner (Front-Left)	3058	1
C Corner (Back-Right)	3059	1
D Corner (Back-Left)	3060	1
E Swivel Plate	3063	2
F Side Rail, 12"	3061	4
G Side Rail, 18"	3062	4
H Actuator Cam	F101	2
I Pivot Rod Bolt	D-125	2
J Wheel	G-705	2
K Swivel Caster	G-706	2
L Rubber Foot	G-209A	2
M 1/4"-20 x 1 3/4" Bolts, Axle	D-115	2
N 1/4"-20 Nuts, Self Locking	D-117	4
O 1/4" -20 x 2 1/4" Bolts, Pivot	D-116	2
P 1/4"-20 x 1/2" Bolts, (Black)	D-114	24
Q 1/4"-20 Nuts, Flanged/Serrated	D-118	24
R 3/8"-16 Nuts	C-305	2
S 3/8"-16 Nuts, Flanged/Serrated	C-405	2
V 1/4"-20 Nuts, Self Locking (Black)	D-134	2