



CX101N
18" VARIABLE SPEED
WOOD & METAL BAND SAW
User Manual



TABLE OF CONTENTS

General Safety Instructions	3
Specific Safety Instructions	4
Features	5
Physical Features	6
Setup	7
Un-packing	7
Proper Grounding	8
Assembly and Adjustments	9
Blade Tracking	12
Basic Controls	13
Test Run	13
Blade Tension	14
Adjusting the Blade Tension	14
Guide Bearings Adjustments	14
Table Stop Adjustment	15
Table Tilt Scale Calibration	16
Table Alignment	16
Guide Post	17
Work-Piece Inspection	17
Work-Piece Inspection (Metal)	18
Blade Selection (Metal)	18
Cast Iron Wheels	19
Coplanar Adjustment	19
Operations	20
Ripping	20
Cross Cutting	20
Re-Sawing	21
Cutting Curves	21
Connecting to a Dust Collector	21
Maintenance	22
Removing/Installing Blade	22
Blade and Table Alignments	22
Tilting the Table Backward	23
Table and Base	23
V-Belts	23
Removing/Replacing the V-Belts	24
Optional Accessories	24
Parts Breakdown and List	25-30
Warranty	31

GENERAL SAFETY INSTRUCTIONS

Extreme caution should be used when operating all machinery. Know your machine, be familiar with its operation, read through the owner's manual and practice safe usage procedures at all times.

- ❖ **ALWAYS** read and understand the user manual before operating the machine.
- ❖ **CONNECT** your machine **ONLY** to the matched and specific power source.
- ❖ **ALWAYS** wear safety glasses respirators, hearing protection and safety shoes, when operating your machine.
- ❖ **DO NOT** wear loose clothing or jewelry and secure long hair in a net or tied back when operating your machine.
- ❖ **A SAFE ENVIRONMENT** is important. Keep the area free of dust, dirt and other debris in the immediate vicinity of your machine.
- ❖ **BE ALERT! DO NOT** use prescription or other drugs that may affect your ability or judgment to safely use your machine.
- ❖ **DISCONNECT** the power source when changing blade and / or making adjustments.
- ❖ **NEVER** leave a tool unattended while it is in operation.
- ❖ **NEVER** reach over the table when the tool is in operation.
- ❖ **ALWAYS** keep blades, knives and bits sharpened and properly aligned.
- ❖ **ALL OPERATIONS MUST BE** performed with the guards in place to ensure safety.
- ❖ **ALWAYS** use push sticks to safely feed your work through the machine.
- ❖ **ALWAYS** make sure that any tools used for adjustments are removed before operating the machine.

CX101N - 18" Variable Speed Wood & Metal Band Saw

SPECIFIC SAFETY INSTRUCTIONS

- ❖ **CX101N** is perfect for cutting various types of wood.
- ❖ **ALWAYS INSPECT** the blade for any cracked or missing teeth before operating the band saw.
- ❖ **ALWAYS ENSURE** that the blade tension is properly set for the type and width of blade installed.
- ❖ **NEVER** place your fingers or hands in the line of cut. If you slip, your hands or fingers may come into contact with the blade. Always use a push stick when ripping narrow pieces.
- ❖ **DO NOT** back the work-piece away from the blade while cutting. Always turn off the machine if you are backing out a cut. ALL GUARDS must be in place while operating the band saw to ensure safety.
- ❖ **ALWAYS FEED** the stock smoothly. Do not force or twist the work-piece while cutting.
- ❖ **ALWAYS ENSURE** that the band saw blade guard is no more than 1/2" above the stock.
- ❖ **MAKE SURE** before making any adjustments, the switch is in the **"OFF"** position and the cord is un-plugged from the power source.
- ❖ **NEVER LEAVE** the band saw unattended while it is running.
- ❖ **DO NOT** attempt to remove jammed pieces unless the band saw has come to a complete stop and the power switch has been turned to the **OFF** position.
- ❖ **NEVER TURN ON** the band saw if the blade is in contact with your workpiece.
- ❖ **ALWAYS ENSURE** that the guide bearings are properly set to prevent blade wander.
- ❖ **ALWAYS MAKE CERTAIN** that the guide bearings are properly adjusted to guide the blade properly.
- ❖ **MAINTAIN AND SERVICE** your band saw regularly as instructed in the user manual.
- ❖ **MAKE SURE** you have read and understood all the safety instructions in the manual and you are familiar with your band saw, before operating the **CX101N**. If you fail to do so, serious injury could occur.

WARNING

The safety instructions given above can not be complete because the environment in every shop is different. Always consider safety first as it applies to your individual working conditions.

CX101N - 18" Variable Speed Wood & Metal Band Saw

FEATURES

As part of the growing line of Craftex woodworking & metalworking equipment, we are proud to offer the CX101N - 18" Variable Speed Wood & Metal Band Saw. The Craftex name guarantees Craft Excellence. By following the instructions and procedures laid out in this user manual, you will receive years of excellent service and satisfaction. The CX101N is a professional tool and like all power tools, proper care and safety procedures should be adhered to.

- ⊠ Motor 1.5 HP, 220 V Single Phase
- ⊠ Switch On/Off Paddle
- ⊠ Variable Speed 150-3000 FPM
- ⊠ Cast Iron Table Size 20" x 24
- ⊠ Table Tilt 0° to 10° Left and 0° to 45° Right
- ⊠ Wheel 18"
- ⊠ Max Blade Width 1/8"
- ⊠ Min Blade Width 1/4"
- ⊠ Maximum Cutting Height 12"
- ⊠ Floor to Table Height.. 37-1/2"
- ⊠ Cutting Capacity/Throat.. 17-1/2"
- ⊠ Dust Collection Ports 2 Ports@ 4"
- ⊠ Blade Length 133"
- ⊠ Bearings Sealed and Permanently Lubricated
- ⊠ Computer Balanced Cast Iron WheelsYes
- ⊠ Co-Planer Adjustment Yes
- ⊠ Powder Coated Paint Yes
- ⊠ Precision Ripping Fence Yes
- ⊠ Quick Release Tension Adjustment Yes
- ⊠ Overall size 39.7" x 30.7" x 76.3"
- ⊠ Carton Size 32.6" x 19.6" x 70.7"
- ⊠ Weight.. N.W 157 KGS / G.W 172 KGS
- ⊠ Warranty 3 Years

CX101N - 18" Variable Speed Wood & Metal Band Saw

PHYSICAL FEATURES



Setup

Before setting up your machine you need to read and understand this user manual completely.

The unpainted surfaces of this band saw are coated with a rust preventive waxy oil and you will want to remove this before you begin assembly. Use a solvent cleaner that will not damage painted surfaces. amount of cleaner/degreaser, then let it soak for 5-10 minutes.

WARNING

CX108N is a heavy machine. Do not over-exert yourself. Use a fork truck or get the help of an assistant or a friend.

Unpacking

The machine is properly packaged in a carton for safe transportation. When unpacking, carefully inspect the crate and ensure that nothing has been damaged during transit. Open the crate and check that the machine is in good condition.

The hardware (screws, washers etc) might be shipped in a plastic bag. After the machine has been un-packed, check that all loose parts and hardware are present.

List of Contents

A. Allen Keys 2, 3mm	2
B. Wrench	1
C. 1/4" Lock Washer	2
D. Flat Washer 5/16"	1
E. 1/4" Lock Washer	2
F. Flat Washer	1
G. Knob Bolt 3/8-16 x 1 1/4	1
H. Hex Bolt 5/16-18x1	1
I. Angle Adjustment Plane	1
J. Hex Bolt 1/4-20x1/2	2
K. Bushing	1
L. Nylon Nut 5/16-18	1
M. Adjustment Bar Bracket	1
N. Square Nut 5/16	4

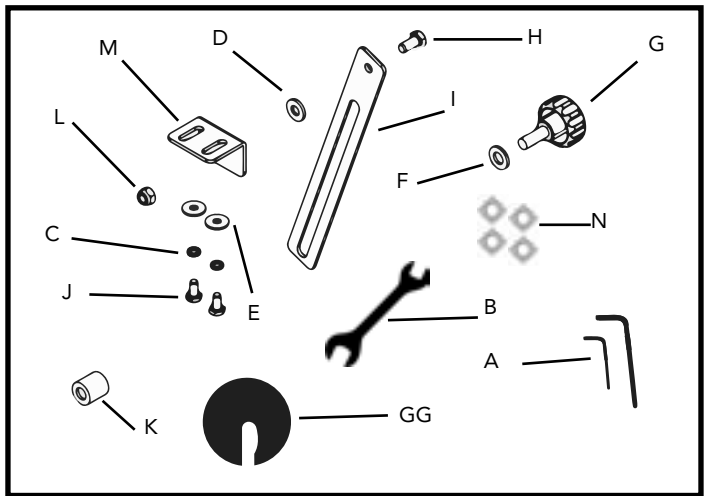

Figure-1 Inventory

List of Contents

O. Flat Washer 1/4"-16 1.2mm	4
P. Hex Bolt 1/4"*5/8"	4
Q. Miter Gauge Holder	1
R. Fence Holder	1
S. Miter Gauge	1
T. Scale (for the front rail)	1
U. Fence Assembly	1
V. Front Rail	1
W. Rear Rail	1
X. Front Rail Brackets	2
Y. Rear Rail Brackets	2
Z. Front Rail Knobs	2
AA. Rear Rail Knobs	2
BB. Flat Washers 3/8"	2
CC. Knobs 3/8"-16	2
DD. Hex Bolts 1/4"-20x1/2"	2
EE. Lock Washer 1/4"	2
FF. Flat Washers 1/4"	2
GG. Table Insert.....	1

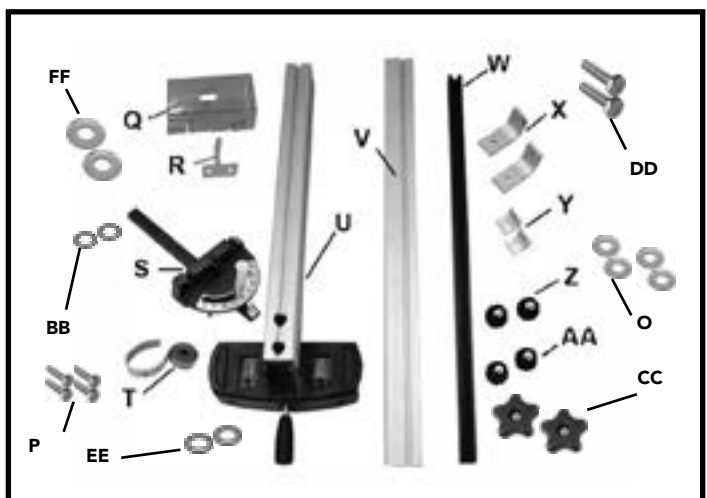

Figure-2 Inventory

Proper Grounding

Grounding provides a path of least resistance for electric current to reduce the risk of electric shock.

CX101N is equipped with a 220 single phase motor which features a 3-conductor cord and a 3-prong grounded plug to fit a grounded type receptacle. Make sure the cord is plugged into a properly installed and grounded power outlet.

To prevent electrical hazards, have a qualified electrician ensure that the line is properly wired.

This appliance is for use on a normal 220-volt circuit and is factory-equipped with a specific electric cord and plug to permit connection to a proper electric circuit. Make sure that the appliance is connected to an outlet having the same configuration as the plug. If an adaptor plug is used, it must be attached to the metal screw of the receptacle.

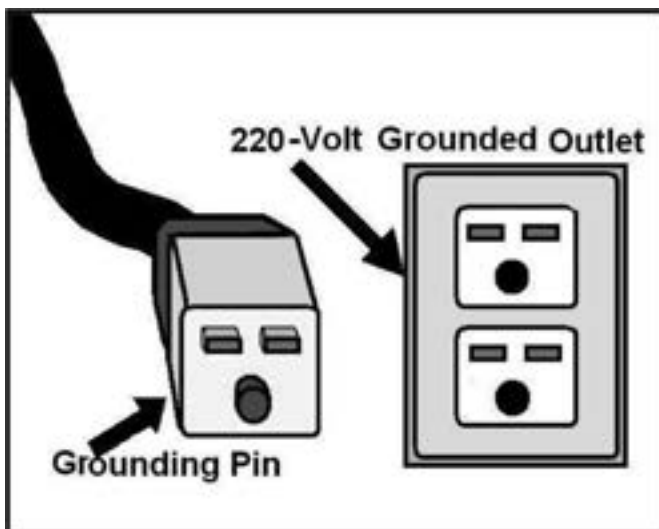

Figure-3 220-Volts Outlet for CX101N



WARNING

Improper connection of the equipment-grounding conductor can result in a risk of electric shock. Check with a qualified electrician if you are in doubt as to whether the outlet is properly grounded.

It is strongly recommended not to use extension cords with your CX101N. Always try to position your machine close to the power source so that you do not need to use extension cords.

In case if you really find it necessary to use an extension cord, make sure the extension cord does not exceed 50-feet in length and the cord is 14-gauge to prevent motor damage.

Your CX101N is equipped with a cord having 3-prongs which fits a 3 prong grounded receptacle as shown in figure-3. Do not remove the grounding prong to fit it into a 2-pronged outlet. Always check with a qualified electrician if you are in doubt.

Assembly

Follow the steps below to assemble your band saw:

Take the band saw table and put it upside down on floor and make sure that all the table bolts shown in the figure are tight. See figure-4

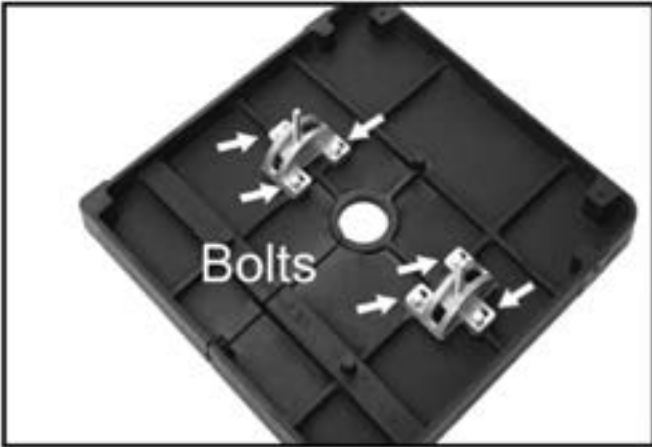

Figure-4 Table turnion bolts

Now turn the table up right, and remove the table pin from the table slot and the table insert (if already installed) and move the table in position around the blade, guiding through the table slot. See figure-5



Figure-5 Installing the table

Position the table on the base in such a way that the bolts under the table extend through the holes on the base. Thread the two knobs on the bolts (do not tighten). See figure-6

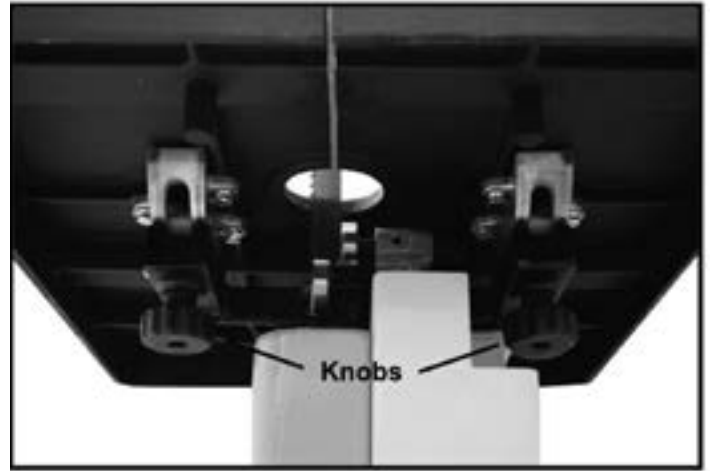

Figure-6 Knobs threaded on the bolts

Position the table on the table stop and the base so that the table is perpendicular to the blade. See page 15 for details.



Figure-7 Table sitting on the table stop

Install the table insert at the center of the table and the table pin into the table slot as shown in figure-8.

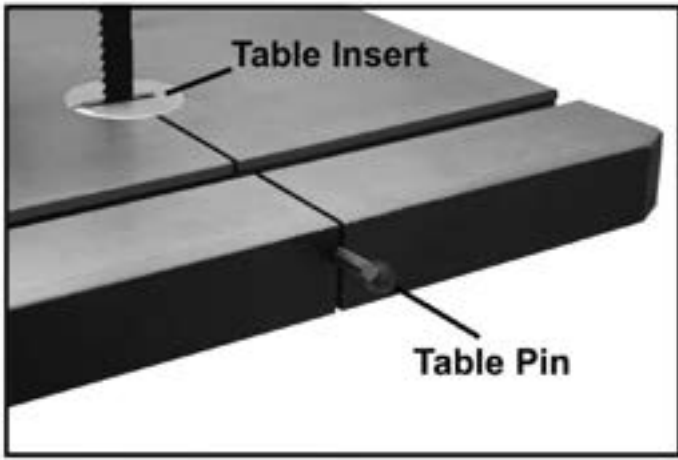

Figure-8 Installing table insert and table pin

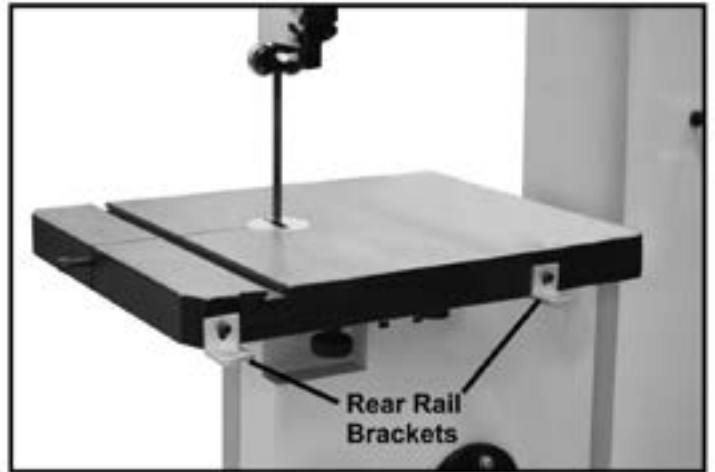

Figure-9 Rear rail brackets attached

Now, attach the rear rail to the brackets using the knobs provided. See figure-10.

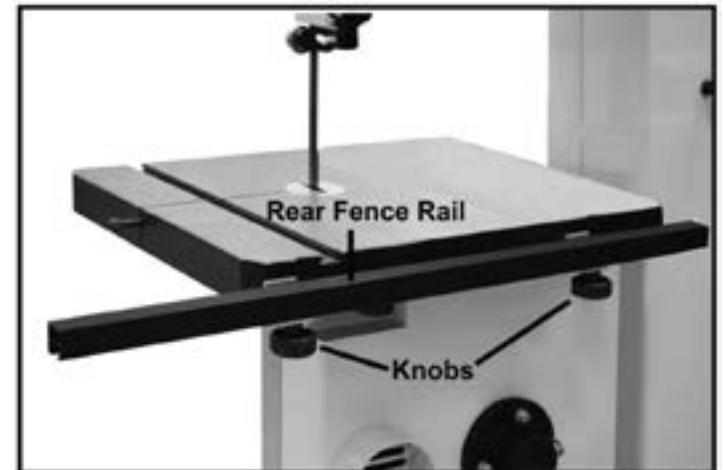

Figure-10 Installing the rear fence rail

Take the rail brackets (larger) for the front fence rail and attach it to the table using the cap screws provided.

Place the front fence rail on the brackets and insert the knobs through the hole on each bracket and thread the T-nuts onto the ends of the knobs a couple of turns to tighten the fence rail in place. See figure-11



Figure-8.5 Installing the angle adjustment brackets

Attach the Adjustment bar bracket to the underside of the table using the 2 screws and the washers. Secure the Angle adjustment plane to the adjustment bar bracket with the hex bolt, washer and the locking nut.

Take the rail bracket (smaller) and attach it to the table using cap screws provided. See figure-9



Figure-11 Front fence rail installed

Now take the fence and pull its handle up. Place the fence on the front fence rail and slide it against the blade.

Use a pencil to mark the fence rail where the fence scale indicator on the right hand side is pointing (there is a gap just behind the indicator plate where you can mark the rail). This mark will indicate where to align the 0" mark when install the scale.

Now, remove the fence from the rail and install the adhesive backed scale on the front fence rail.



Figure-12 Adhesive backed scale attached to the front rail

Once you have attached the adhesive backed scale to the rail, place the fence on the rail and tighten it in place by pushing down the handle. See figure-13

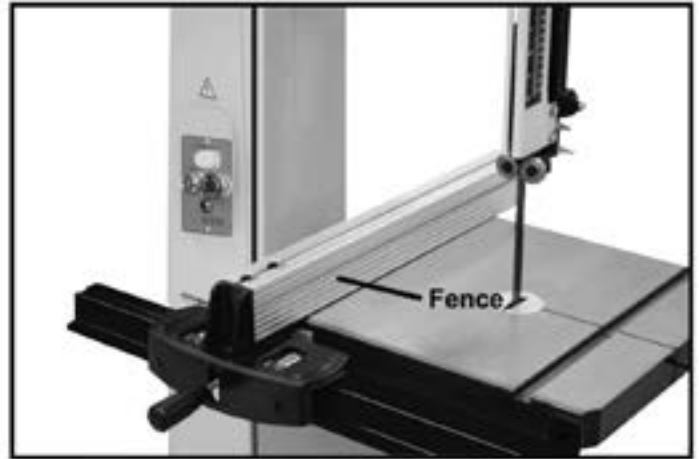

Figure-13 Fence installed on the rails

Attach the miter gauge holder and the fence holder to the back of the saw using screws and washers provided see figure-14

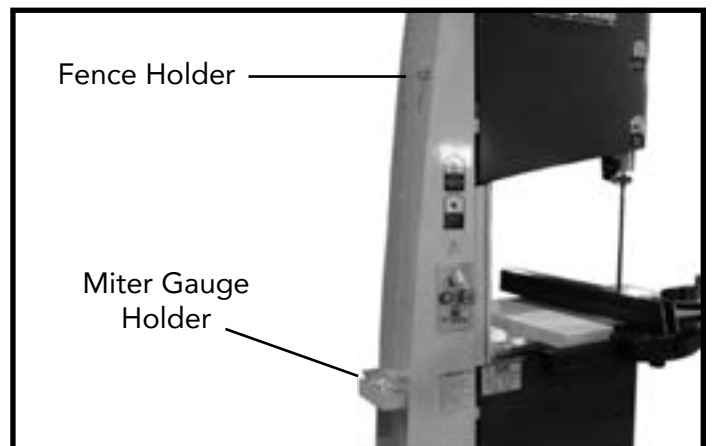

Figure-14 Miter gauge holder and fence holder installed

Blade Tracking

Blade tracking refers to the blade remaining in the same position on the upper and lower wheels. When rotating the wheel by hand, if it moves forward or backward on the wheel then tracking needs to be adjusted.

Although the blade tracking of this band saw is factory set, you should check it again to make sure that the blade is centered on the wheels. Blade tracking blade can be controlled by adjusting the blade tracking knobs.

Disconnect the machine from power and open the upper wheel cover. Rotate the upper wheel by hand slowly and see how the blade rides on the wheel.

If the blade is not properly aligned and needs to be adjusted, loosen the lock nuts shown in figure-15 and turn the knobs.

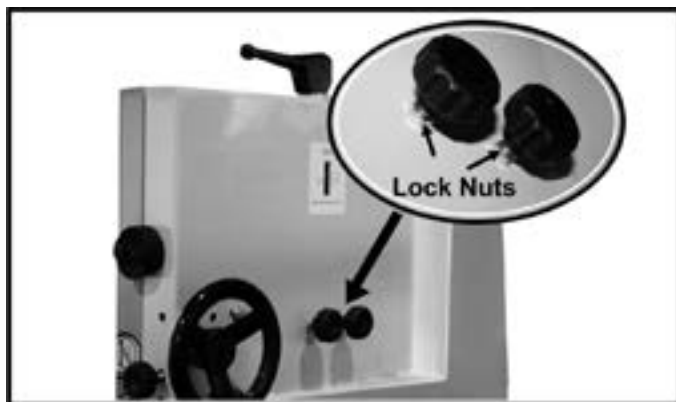

Figure-15 Knobs and Locks Nuts

Turn the knobs clockwise:

If the blade moves towards the front edge of the wheel. It makes the top of the wheel to tilt back and moves the blade towards the center.

Turn the knobs counter-clockwise:

If the blade moves towards the back edge of the wheel. It makes the top of the wheel

to tilt to the front and moves the blade towards the center.

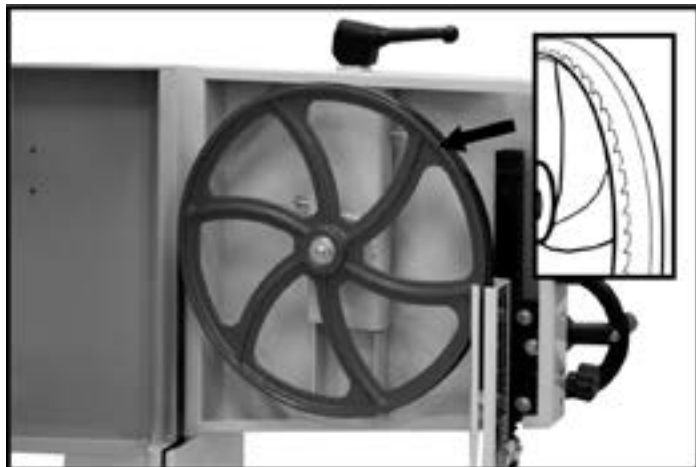

Figure-16 Blade centered on the wheel

When you have adjusted the blade tracking, re-tighten the lock nuts.

IMPORTANT

In very rare cases if the blade tracking is not adjusted by tilting the upper wheel, then you will have to make minor adjustments to the angle of tilt of the lower wheel. Loosen the four hex bolts and to tilt the lower wheel to get the proper angle of tilt and tighten the bolts back. Remember, this adjustment is done only if the blade tracking is not adjusted by tilting the upper wheel.



Figure-17 Lower wheel adjustment sleeves

Basic Controls

The basic controls of this machine are shown in the figure below. Use the figure and read the text to understand what the basic controls of this band saw are.

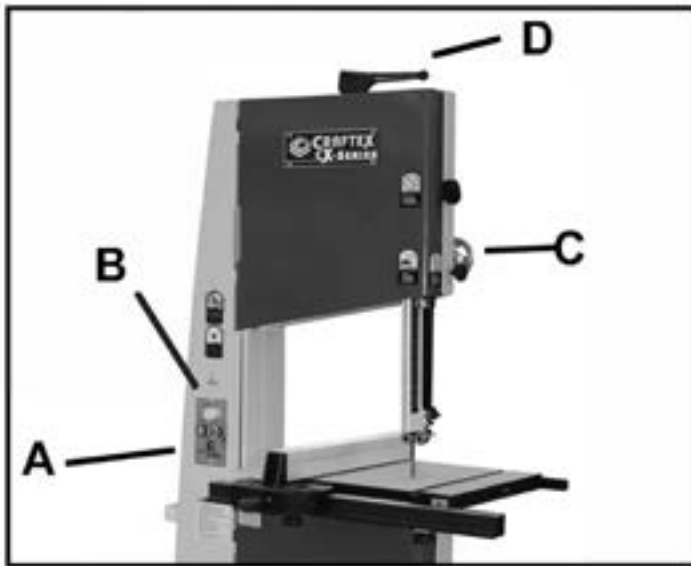

Figure-18 Basic controls of CX101N

- A.** The power switch turns the power on/off to the motor switch.
- B.** The motor switch start and stops the motor and only works after the power switch has been turned on.
- C.** The guide post hand wheel raises or lowers the post guide post.
- D.** The blade tension/ quick release lever increase or decreases blade tension when rotated. Lifting the handle activates the quick release.

IMPORTANT

Make sure you have done the tracking adjustment and the blade is centered on the wheels before you start the band saw for a test run. See page-12 for details on blade tracking.



WARNING

This machine can perform many types of operations which are beyond the scope of this manual and are very dangerous if performed incorrectly. The safety instructions given in this manual can not be complete because the environment in every shop is different. Always consider safety first as it applies to your individual working conditions.

TEST RUN

Once you have assembled your machine completely, it is then time for a test run to make sure that the machine works properly and is ready for operation.

During the test run if there is any unusual noise coming from the machine or the machine vibrates strangely, stop the machine immediately and disconnect from the power source and investigate the source of the problem with your machine. Refer to the trouble shooting.

READ THE MANUAL

Before starting the band saw, make sure that you have read and understood the manual and you are familiar with the functions and safety features on this machine. Failure to do so may cause serious personal injury.

Blade Tension

A properly tensioned blade is very important to get the best performance from any band saw. If the blade is too loose there is a possibility that the blade will slip or drift off the line while in operation and it will be hard to have accuracy in the line of cut. If the blade is tensioned too tightly, it will be very difficult to make tighter radius cuts and there will be a greater possibility of blade breakage.

When using a wider blade for making straight cuts, for re-sawing or making wide radius cuts, tighter blade tension is recommended; while using narrower blades for cutting shorter stock or making tighter radius cuts, less blade tension is recommended.

The information above is just a guideline for you to understand to set the blade tension according to the cut. However, understanding the blade tension adjustment comes with practice with the machine.

Look at the blade tension scale located at the back of your band saw. The scale shows the ideal blade tension adjustment according to the width of the blade.

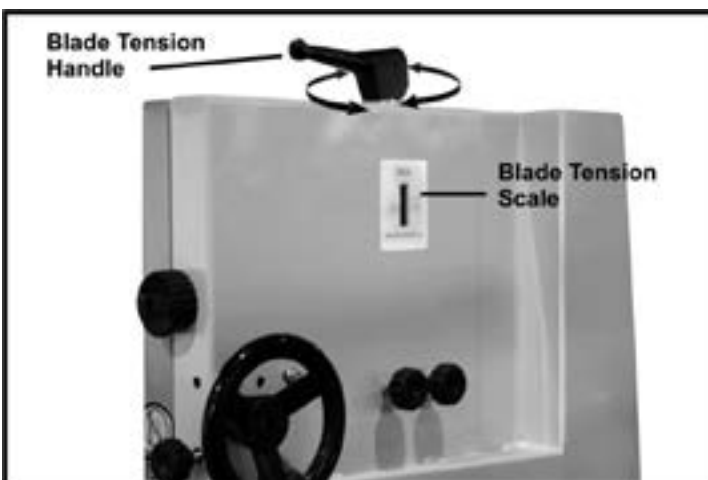

Figure-19 Quick release blade tension handle and scale

Adjusting the Blade Tension

To adjust the blade tension, lift the blade tension handle shown in figure-19 and turn it. Turning the handle clockwise will increase the tension on the blade while turning the handle counter-clockwise will decrease the blade tension.

IMPORTANT

All blades stretch with use, and the scale at the back of your band saw (shown in figure-19) is just an approximation. So, do not rely on any adjusted measurement for a long period of time as the blades stretch and the tension on the blade changes.

IMPORTANT

To prolong the life of the blade and reduce blade stretching, when the machine is not in use for period of 24 hours or more release the tension on the blade.

Guide Bearings Adjustment

The guide bearings (beside) and thrust bearing (behind) the blade, support the blade during cutting operations. Properly adjusted support bearings play, an important role in getting accurate cuts.

To adjust the guide bearings, turn the machine off and disconnect the cord from the power source and prevents the blade from wondering, therefore producing straight cuts.

Remove the blade guard and use a screw driver to loosen the screws located on each of the two guide bearings as shown in figure-20.

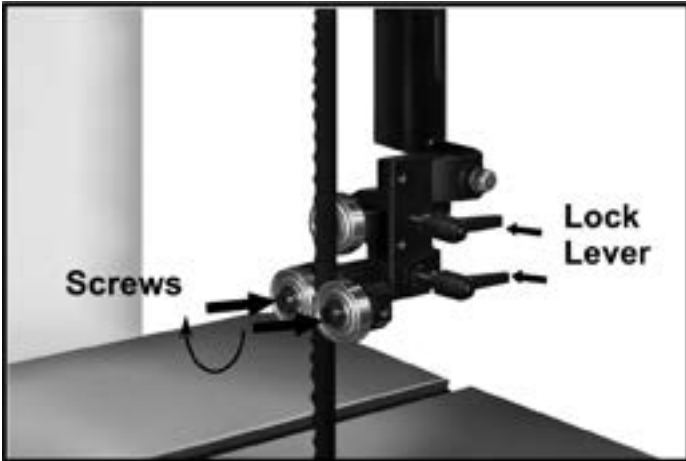

Figure-20 Set Screws

Adjust the bearings so that the space between the guide bearing and the blade should be 0.02" which is thickness of a sheet of paper. See figure-21

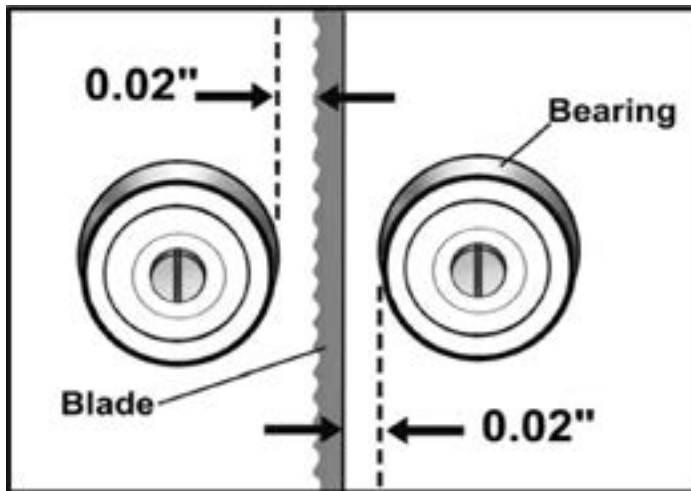

Figure-21 Distance between the guide bearings and the blade

Now, retighten the set screws to lock the guide bearings in place.

Loosen the lock levers shown in figure-22 and move the bearing shafts in or out so that the guide bearings are 1/32" behind the blade teeth and the thrust bearing, 1/64". Once the bearings are at the correct position behind the blade, tighten the lock lever to lock the bearings in place. See figure-22.

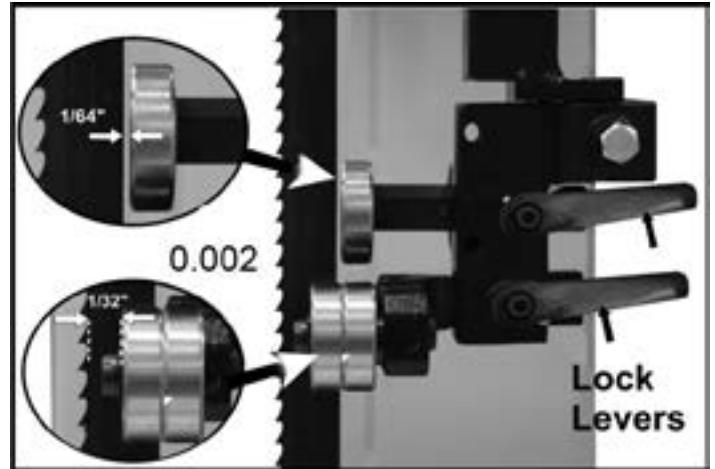

Figure-22 Distance of the bearings behind the blade

Adjust the lower bearings in the same manner.

Table Stop Adjustment

CX101N features a table stop which allows the table to easily come to a 90° if the table is tilted.

To adjust the table stop so that the table sits at 90°, you should first make sure the switch is in "OFF" position and the power cord is unplugged. Loosen the two lock knobs under the table and loosen the hex nut which locks the table stop bolt.

Now, place a square on the table as shown in figure-23 and adjust the table stop so that the table is at a 90° with the blade.

Table Alignment

To make accurate cuts with your band saw, the table should be aligned properly with the blade.

To align the table:

Make sure the blade tension and tracking is done correctly. Disconnect the machine from the power source and loosen the table trunnion bolts under the table shown in figure-25.

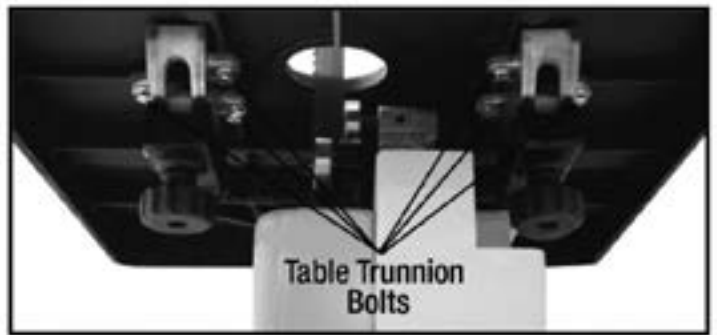

Figure-25 Table trunnion bolts

Place a straightedge on the table so that the straightedge touches the blade and is parallel to it as shown in figure-25. Make sure the straight-edge touches only the flat part of the blade, not the teeth.

Now, use a ruler to measure the distance between the miter slot and the straight edge on both sides on the table R & L. See figure-26

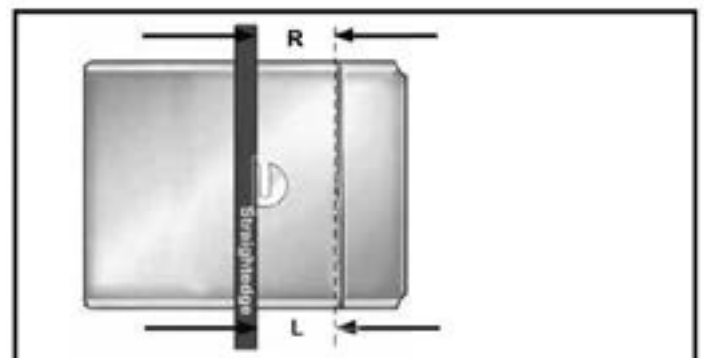

Figure-26 Aligning the table with the blade using a straight-edge

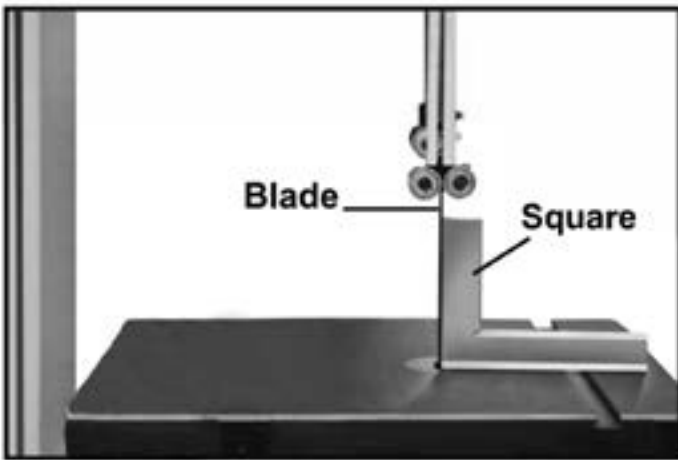

Figure-23 Adjusting the table at 90° to the table using square

Once the table is at 90° with the blade, tighten the hex nut and the knobs.

Table Tilt Scale Calibration

To calibrate the table tilt scale:

Make sure the table is at 90° to the blade and the blade tensioning and tracking is properly set. (See Page 12 & page 14 for details)

Disconnect the machine from the power source and loosen the pointer screw shown in figure-24. Align the tip of the pointer with the 0" mark on the tilt scale and tighten the pointer screw.



Figure-24 Table tilt scale

Adjust the table until the distance on both sides of the table is equal and tighten the table trunnion bolts.

Guide Post

The guide post assembly can be moved up or down above the work-piece. The movement of the guide post is controlled with the hand wheel shown in figure-27.

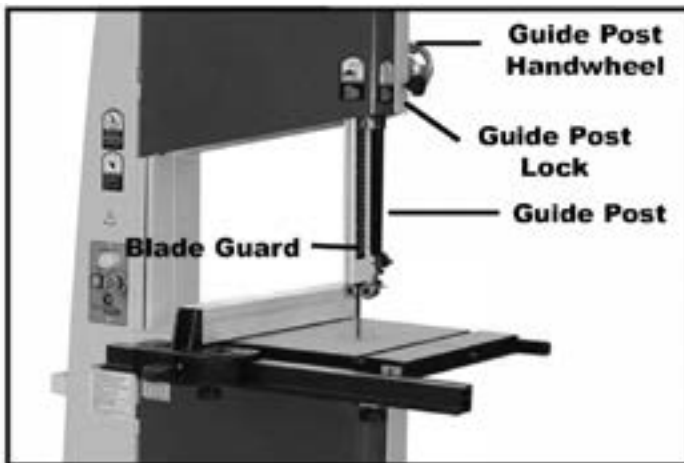

Figure-27 Guide post

To make accurate cuts and to reduce the blade slipping out of position, it is recommended to keep the guide post no more than 1" above the work-piece while cutting operation.

To Adjust the Guide Post Assembly:

Make sure the switch is turned off and the cord is disconnected from the power source.

Loosen the guide post lock knob on your band saw shown in figure-27 and rotate the hand-wheel to move the guide post assembly up or down.

When the guide post assembly is about 1" above the work-piece, lock the guide post in place using the lock knob.

Work-piece Inspection (Wood)

Before cutting any wood, make sure to inspect the work-piece for nails, staples, small pieces of stone or metal and any other object which might come in contact with the blade.

If the wood contains any of these objects and it comes in contact with the blade, the object might fly and hit the operator or seriously damage the blade. For a safe cutting method always inspect your workpiece carefully before cut and wear eye protection.

Some woods with excessive twisting or warping are un-stable while cutting and are dangerous to cut because during operation the work-piece can move unexpectedly which either damages the blade or hurts the operator.

If the wood is slightly cupped, make sure the cupped face of the wood is held against the fence. If the bowed side of the workpiece is held against the fence, the workpiece will move while cutting.



WARNING

The information above is just a guideline for you to understand how to cut a workpiece with slight cupping. If you are not sure and do not have any experience in cutting cupped stock, do not cut it. Failure to follow these instructions might bring personal injuries to the operator or serious damage to the blade.

Some stock with large knots can damage the blade and wet stock will give a poor result.

RECOMMENDED CUTTING SPEED

Material	Speed FPM (M/Min)	Material	Speed FPM (M/Min)	Material	Speed FPM (M/Min)	Material	Speed FPM (M/Min)
Carbon Steel	196-354 (60) (108)	Tool Steel	203 (62)	Alloy Steel	111-321 (34) (98)	Stainless Steel	150-203 (46) (62)
Angle Steel	180-220 (54) (67)	High Speed Tool Steel	75-118 (25) (36)	Mold Steel	246 (75)	Gray Cast Iron	108-225 (33) (75)
Aluminum Alloy	220-534 (67) (163)	Hot Work Tool Steel	203 (62)	Stainless Steak	85 (26)	Malleable Cast Iron	321 (98)

Work-Piece Inspection (Metal)

Before cutting a metal work-piece, inspect it carefully for any defects in the material.

For thin or small metals, the work-piece should be clamped between larger pieces to hold the work-piece tight, when fed against the blade.

Some small work-pieces will be damaged if cut on the band saw; instead use shear or nibblers for this work.

Some round work-pieces like cables, chains etc, which are not stable, if not supported with a vise, should not be cut using a vertical band saw.

Some hard metals take a longer time when cutting. These kinds of metals need a different type of blade and lubrication while cutting.

Tanks, cylinders, valves that contain gasses or liquids can cause fire, explosion or serious personal injury and damage to the machine.

IMPORTANT

Avoid cutting tanks, cylinders and valves that contain gasses or liquids if possible. If you find it really necessary to cut these items, always vent and purge them, before cutting.

Sometimes it is not safe to cut magnesium. Cutting magnesium with a dull blade can create enough friction to make the small magnesium chips produce fire. Avoid cutting magnesium if possible.

Cast Iron Wheels

The CX101N comes with heavy duty cast iron wheels for added stability and overall performance.

A coplanar shim adjustment also added for better alignment of the wheels that allow the blade to run as straight as possible ensuring straight and accurate cuts.

This feature will help improve the band saw performance with the wheels working together instead of against each other. The end result will give you less vibration, more power, accuracy and less wandering. This will be noticed most when it comes to resawing and making straight cuts with blades larger than 1/4".

Coplanar Adjustment

Figure-28 and Figure-29 show the shim for adjusting the top wheel. To move the wheel out remove the nut and shims then remove the wheel.

Now you can add shims to the back of the wheels as required. Replace the wheel and any remaining shims and the nut and tighten. To move the wheel in, remove the cast iron wheel as mentioned above and remove the shims from behind the wheel. Replace the wheel, shims and nut and retighten.

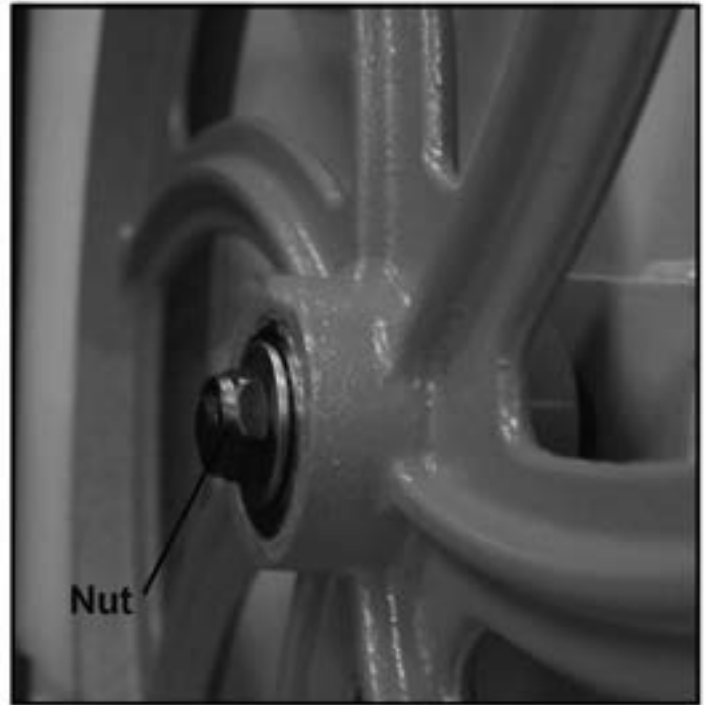

Figure-28 Washer

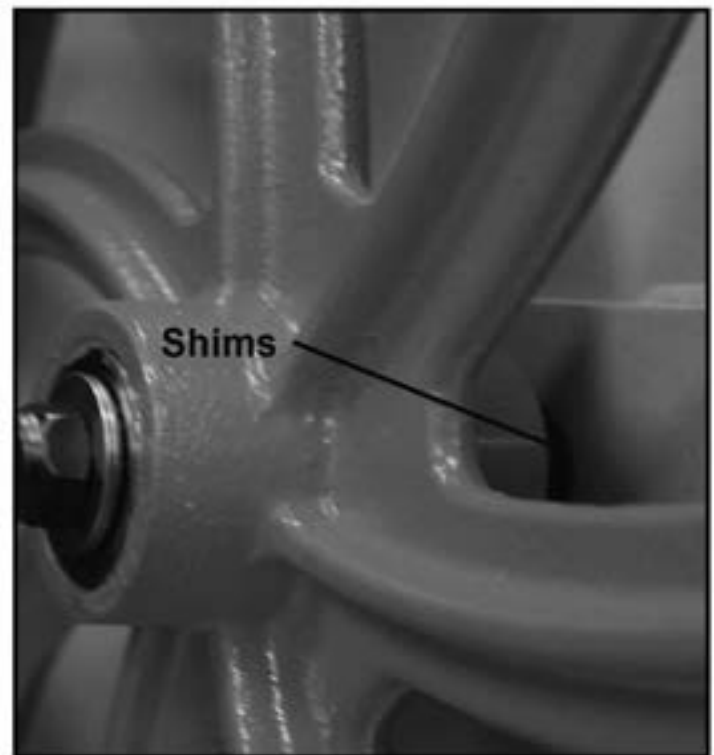

Figure-29 Top wheel back shims

Operations

Before operating the band saw make sure you have performed the following adjustments:

- ❖ Blade tension adjustment
- ❖ Blade tracking adjustment
- ❖ Guide bearings adjustment
- ❖ Make sure all the guards are in place



WARNING

CX101N produces fine dust particles during cutting operation which is very dangerous for health. Always connect your band saw to a dust collector.

Ripping

Cutting solid wood with the grain cutting down the length of the work-piece is called ripping.

Adjust the fence on the rails, according to the width of the cut on the work-piece and turn the hand-wheel to set the guide post assembly 1" above the work-piece.

Now, turn the band saw ON and use a push stick to push the work-piece against the blade. See figure-30.



WARNING

Do not use your fingers to feed narrow work-pieces into the blade. If you slip, your fingers might come close the blade. Always use a push stick.

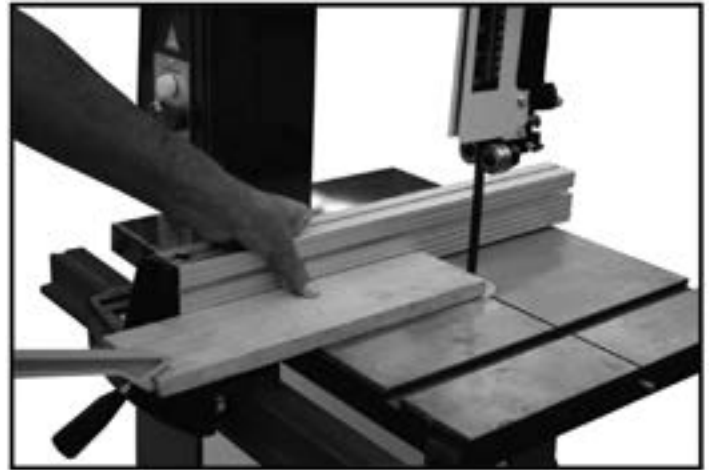

Figure-30 Ripping on CX101N

Crosscutting

Cutting solid wood across the grain and in plywood cutting across the width of the work-piece is called crosscutting.

Mark the work-piece where you want to start the cut from and make sure the miter gauge is at 90° position on the miter slot. Place the work-piece on the table so that the marked point is aligned with the blade and hold the work-piece against the miter gauge.

Turn the band saw ON and feed the workpiece against the blade. See figure-31.

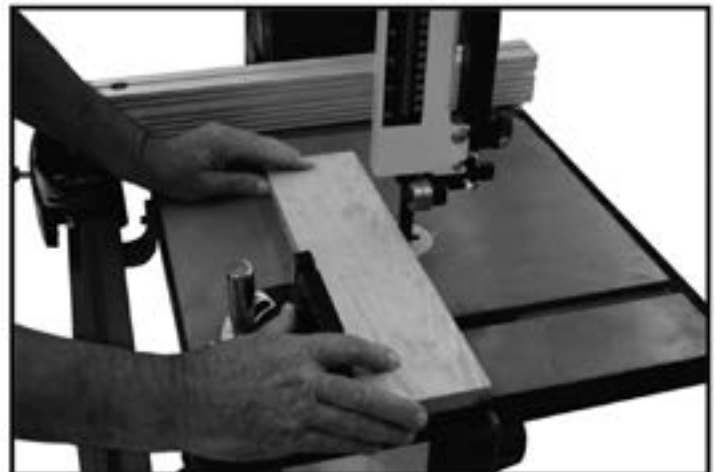

Figure-31 Crosscutting on CX101N

Resawing

Cutting a work-piece into two or more thinner pieces is called resawing. Wider blades give better result, when resawing.

To resaw a work-piece make sure that the table is at a 90° with the blade and use a wider blade for better results.

Adjust the fence according to the width of the cut you want, and lock it in position. Turn the band saw ON and feed the workpiece into the blade using feed paddles until the blade is completely through the workpiece.

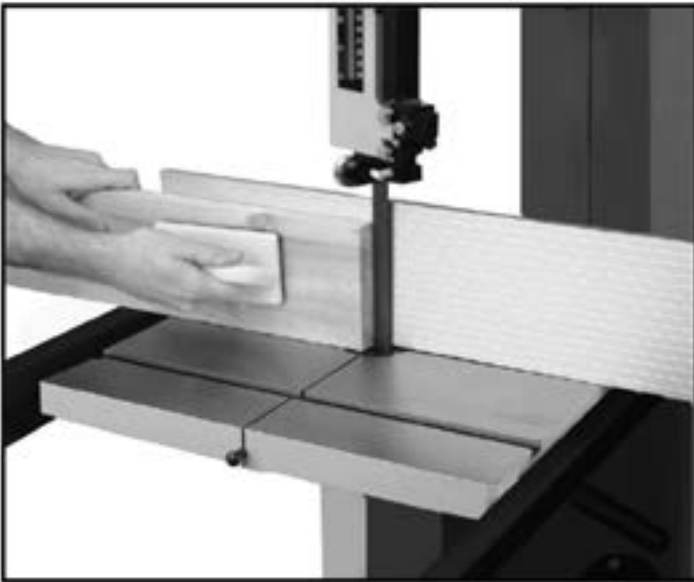

Figure-32 Resawing on CX101N

Cutting Curves

For cutting curves always try to use narrower blades. When cutting curves feed the stock into the blade and turn it very carefully so that the blade follows the line of cut and make sure the blade does not twist.

Make relief cuts through the waste part of the work-piece which makes the job easier and prevents the blade from twisting.

Connecting to a Dust Collector

CX101N features two 4" diameter dust ports to connect to a dust collector.

When connecting to a dust collector, use a proper sized hose and make sure all the connections are sealed tightly.

You should use a dust collector with at least a 500 CFM rating.

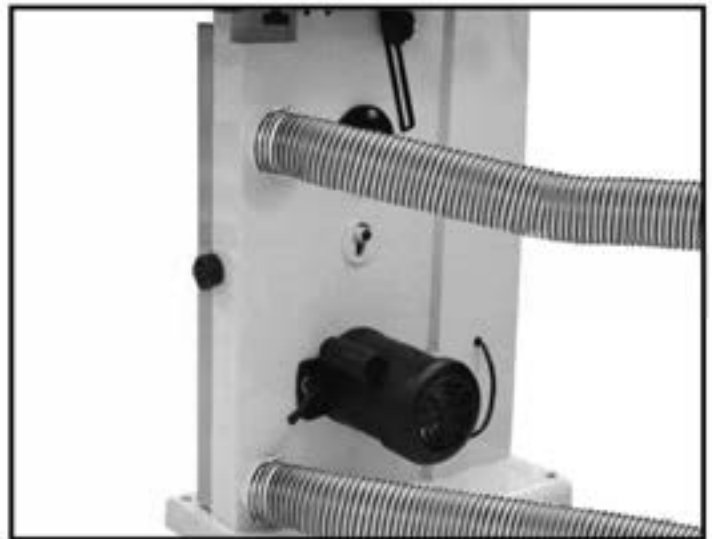

Figure-33 CX101N connected to dust collector



WARNING

The saw dust produced by the band saw can go into your lungs and cause serious health problems. Make sure the band saw is connected to a dust collection system while operating it.

Maintenance

During the life of your machine, you will need to practice some regular maintenance to keep your saw in peak performance condition.

Removing the Blade

To remove / change the blade, turn the switch OFF and disconnect the cord from the power source.

Release the blade tension lever, and remove the table insert and the table pin.

Open the upper and lower wheel cabinets and carefully slide the blade off of both wheels.

Now, slide the blade out, through the slot on the table.

To install the new blade

Once the old blade is removed, carefully slide in the new blade through the slot on the table so that the teeth of the blade are pointing downwards.

Position the blade through the upper and lower guide bearings and install it over the wheels.

Check the blade tracking (See page-12) and adjust the guide bearings (See page-14).

Once the blade is in the proper position, turn the tension lever to tension the blade.



Figure-34 Installing the new blade

Close the top and bottom cabinets and re-insert the table pin and table insert into the table.



WARNING

When installing / removing and servicing any part of the machine, make sure the power switch is in the off position and the cord is disconnected from the power source. Failure to do so may result in serious personal injury or death.

Blade and Table Adjustment

The blade and table alignments should often be checked, and make sure the blade is at a 90° with the table.

See page-16 "Table Alignment" for details.

Tilting the Table Backward

To tilt the table backward, you will need to loosen the bolts shown in figure-35 and adjust them as needed using a wrench.

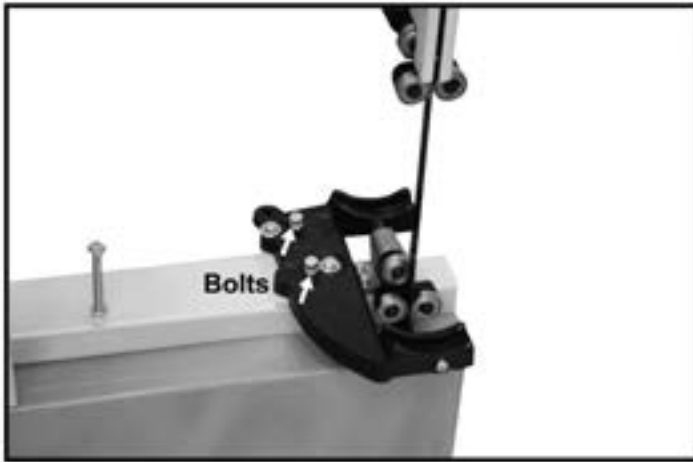

Figure-35 Bolts to tilt the table backward

Table and Base

The moisture from the wood dust remains on the table surface and can cause rust. Protect the un-painted cast iron surfaces of the table by cleaning the table after every use or apply a protective coating.

If the table becomes harder to tilt, remove the table and apply a few drops of oil on the trunnions.

V-Belts

The V-belts stretch with use, and should be re-tensioned periodically. To ensure optimum power transfer from the motor to the blade, the belt must be in good condition and under proper tension.

Check the V-belts at least after every 3 months and more often if the band saw is used daily.

To Inspect the V-Belts

1. Turn the power switch off and disconnect the cord from the power source.
2. Lift the blade tension handle up and release the tension.
3. Open the lower and upper cabinet and remove the blade. (See page-21 Removing/Changing the Blade)
4. Remove the lower wheel by removing the nut bolt securing the wheel to the saw body. See figure-36.
5. Once the wheel is removed, you will have access to the V-belts. Check if the V-belts are in good condition and properly tensioned.

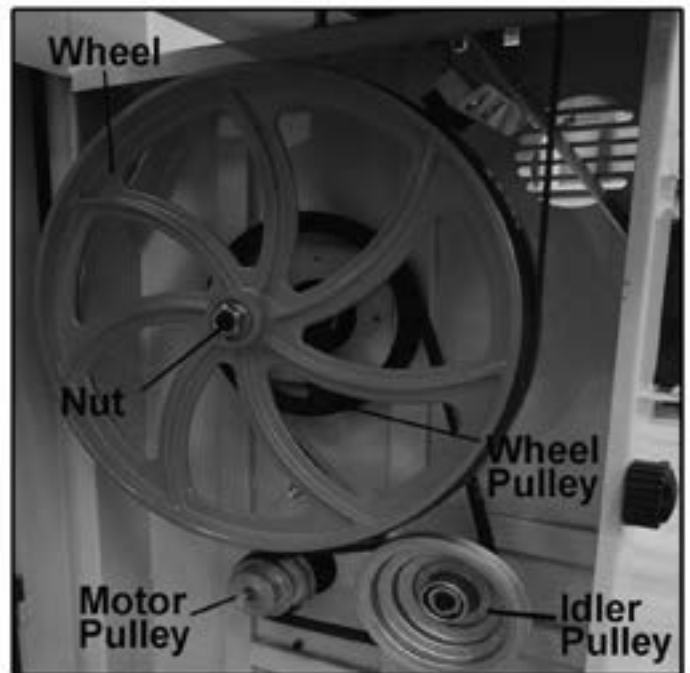

Figure-36 Lower wheel and pulleys

To Replace the V-Belts

6. Follow the instructions 1-5 to access the V-belts.
7. Loosen the motor lock lever shown in figure-37 and idler pulley mounting nut shown in figure-38.



Figure-37 Motor lock lever

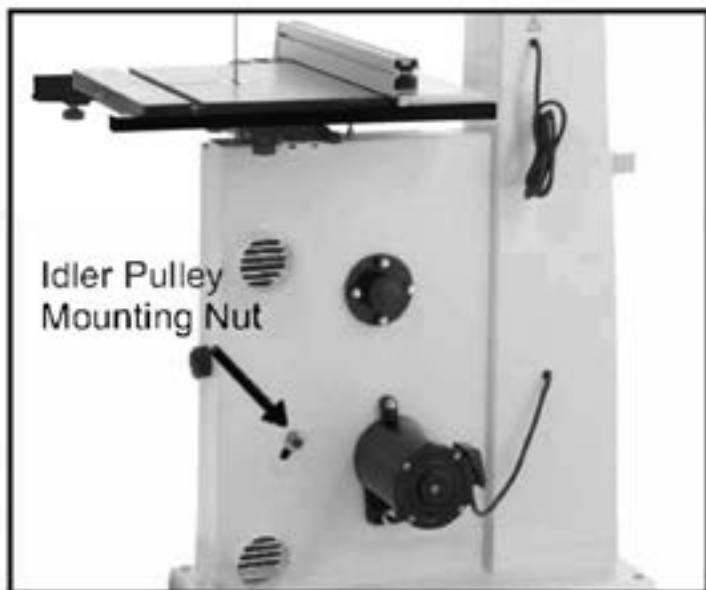

Figure-38 Idler pulley mounting nut

8. Pivot the motor and slide the idler pulley to loosen up the belt.
9. Remove the old belt and install the new one.
10. Slide the idler pulley down to tighten the lower wheel V-belt. Keep pressure on the idler pulley and tighten the mounting nut.
11. Check the wheel pulley V-belt if tensioned properly. If tension is necessary, pivot the motor to tighten the motor V-belt. Keep pressure on the motor and tighten the motor adjustment bolt.
12. Check the motor V-belt, if properly tensioned and tighten the motor hinge bolt.
13. Install back the wheel, blade and close the cabinets.



WARNING

When installing or removing and servicing any part of the machine, make sure the power switch is in the off position and the cord is disconnected from the power source. Failure to do so may result in serious personal injury or death .

CX101N PARTS DIAGRAM

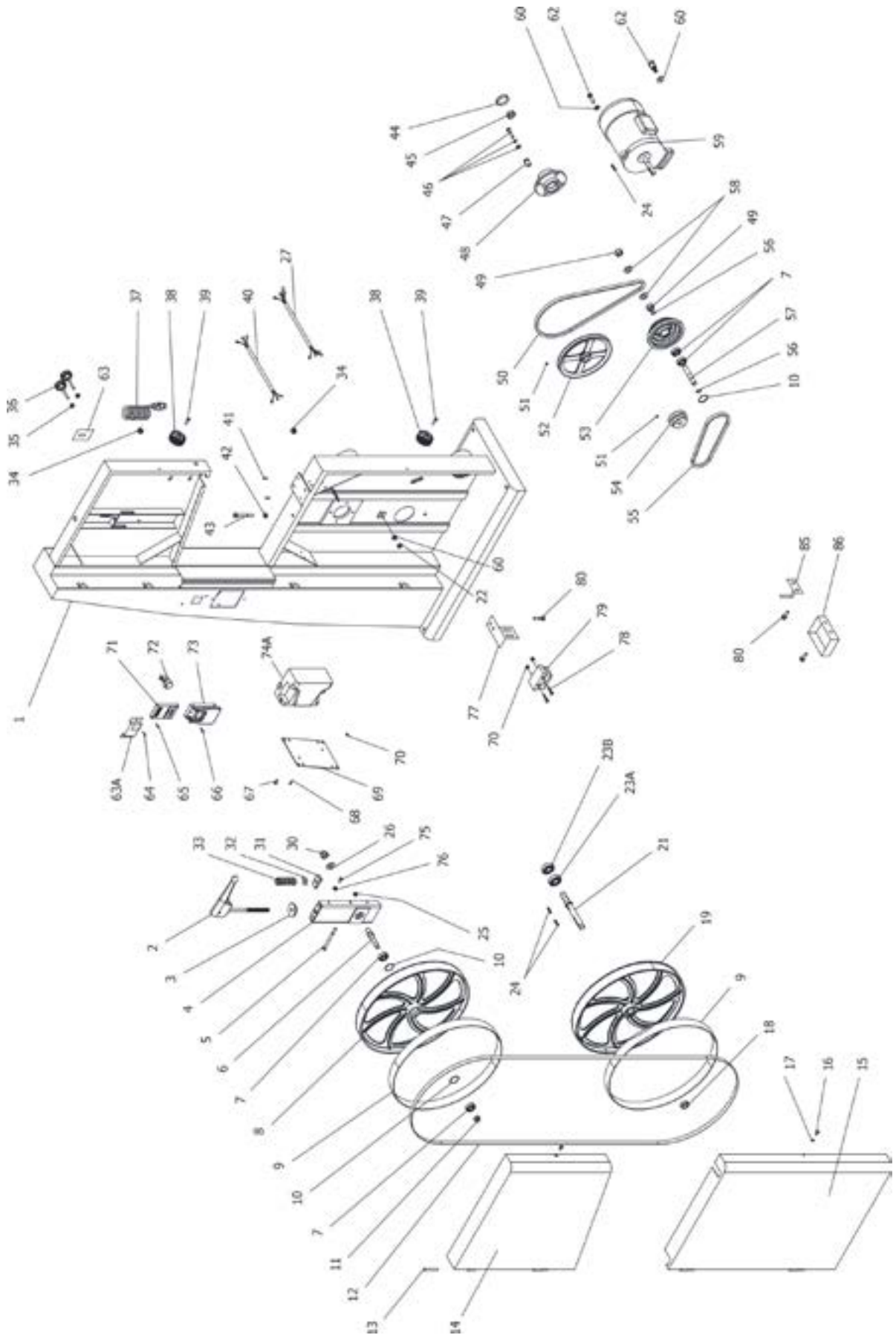

CX101N PARTS LIST

KEY	REF #	DESCRIPTION
1	PCX101N01	BODY
2	PCX101N02	QUICK HANDLE BAR
3	PCX101N03	T TYPE WASHER
4	PCX101N04	UPPER WHEEL BRACKET
5	PCX101N05	HEX BOLT-M8*110m
6	PCX101N06	UPPER WHEEL SHAFT 17MM
7	PCX101N07	BEARING
8	PCX101N08	UPPER WHEEL
9	PCX101N09	WHEEL TIRE
10	PCX101N10	INTERNAL RETAINING RING R40
10A	PCX101N10A	C-RING R-40MM
11	PCX101N11	RETAINER NUT 1/2"-P12
12	PCX101N12	BLADE 133" LONG
13	PCX101N13	HINGE PIN
14	PCX101N14	UPPER GUARD
15	PCX101N15	LOWER GUARD
16	PCX101N16	CAP SCREW 1/4"-20P*3/8"
17	PCX101N17	LOCK WASHER 1/4"
18	PCX101N18	HEX NUT 3/4"-16P(L.H)
19	PCX101N19	LOWER WHEEL
21	PCX101N21	LOWER WHEEL SHAFT
22	PCX101N22	LOCK NUT 3/8"-16P
23A	PCX101N23A	BEARING 6205
23B	PCX101N23B	BEARING 6005
24	PCX101N24	KEY 5*5*35MM
25	PCX101N25	NYLON NUT M8-P1.25
26	PCX101N26	SPRING WASHER
27	PCX101N27	MOTOR CORD
30A	PCX101N30A	HEX NUT 5/8"
31	PCX101N31	NUT
32	PCX101N32	BLADE TENSION POINTER
33	PCX101N33	SPRING
34	PCX101N34	STRAIN RELIEF
35	PCX101N35	HEX NUT 5/16"-18P
36	PCX101N36	KNOB 5/16-18X2
37	PCX101N37	POWER CORD
38	PCX101N38	GUARD LOCKING KNOB
39	PCX101N39	SPECIAL HIGH CAP SCREW 7x19-1/4"
40	PCX101N40	CORD
41	PCX101N41	PIN 6*16MM
42	PCX101N42	HEX NUT 3/8"-16P

KEY	REF #	DESCRIPTION
43	PCX101N43	HEX BOLT 3/8-16P*4"
44	PCX101N44	BEARING COVER
45	PCX101N45	HEX NUT 3/4"-16P
46	PCX101N46	HEX BOLT 5/16-18P*1-1/2"
47	PCX101N47	ADJUSTING SCREW
48	PCX101N48	BEARING BASE
49	PCX101N49	HEX BOLT 5/8"-11P
50	PCX101N50	V-BELT A41
51	PCX101N51	SET SCREW 1/4-20P* 1/4"
52A	PCX101N52A	WHEEL PULLEY
53	PCX101N53	IDLER PULLEY
54	PCX101N54	MOTOR PULLEY
55	PCX101N55	V-BELT A30
56	PCX101N56	EXTERNAL RETAINING RING S15
57	PCX101N57	SHAFT
58	PCX101N58	FLAT WASHER 5/8"
59	PCX101N59	MOTOR
60	PCX101N60	FLAT WASHER 3/8"
62	PCX101N61	HEX BOLT 3/8*1-3/4"
63	PCX101N63	TENSION LABEL
63A	PCX101N63A	TENSION LABEL
64	PCX101N64	PHILLIPS FLAT HEAD SCREW M4*6
65	PCX101N65	PHILLIPS HEAD SCREW M3*18
66	PCX101N66	PHILLIPS HEAD SCREW 3/16*3/4
67	PCX101N67	PHILLIPS FLAT HEAD SCREW 1/4*1/2"
68	PCX101N68	PHILLIPS FLAT HEAD SCREW 3/16*1/2"
69	PCX101N69	CONTROLLER COVER PLATE
70	PCX101N70	HEX NUT 3/16"
71A	PCX101N71A	MOTOR INVERTER SWITCH
72	PCX101N72	SPEED DIAL
73	PCX101N73	SWITCH W/LARGE STOP
74A	PCX101N74A	AC MOTOR CONTROLLER
75	PCX101N75	HEX BOLT 5/16*3/4
76	PCX101N76	HEX NUT 5/16"-18P
77	PCX101N77	BRUSH BASE
78	PCX101N78	PHILLIPS FLAT HEAD SCREW 3/16*1-1/2"
79	PCX101N79	BRUSH
80	PCX101N80	HEX BOLT 1/4-20P*3/4"
85	PCX101N85	HOLDER
86	PCX101N86	TOOL TRAY

CX101N PARTS DIAGRAM

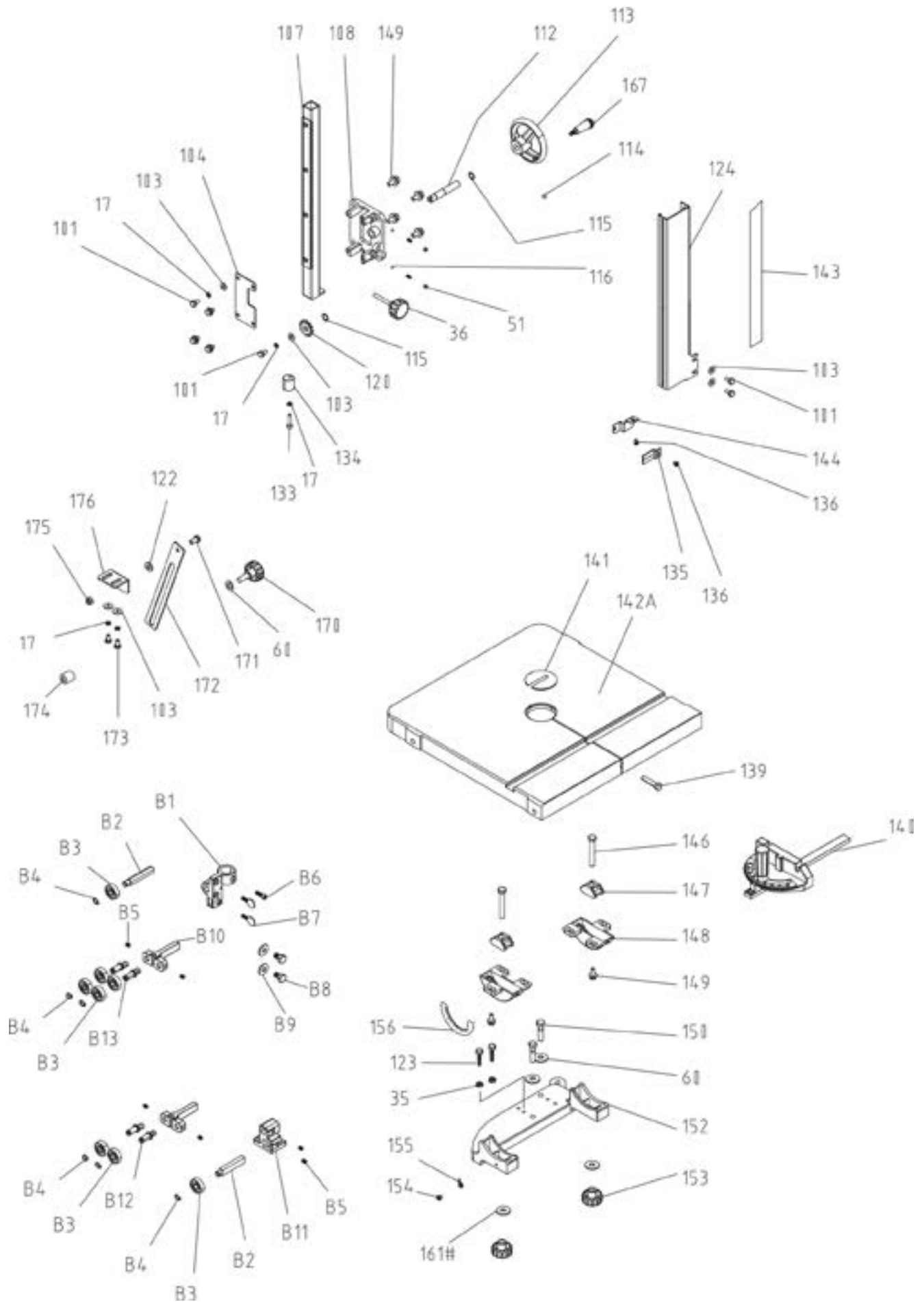

CX101N TABLE PARTS LIST

KEY	REF #	DESCRIPTION	KEY	REF#	DESCRIPTION
101	PCX101N101	HEX BOLT 1/4-20P*3/8"	150	PCX101N150	HEX BOLT 3/8*2"
103	PCX101N103	FLAT WASHER 1/4-16*1.2MM	152	PCX101N152	TRUNNION SUPPORT BRACKET
104	PCX101N104	GUIDE BAR COVER	153	PCX101N153	KNOB
107	PCX101N107	GUIDE BAR	154	PCX101N154	PHILLIPS HEAD SCREW 3/16"-24P*1/4"
108	PCX101N108	BRACKET	155	PCX101N155	POINTER
112	PCX101N112	PINION SHAFT	156	PCX101N156	GAUGE LABEL
113	PCX101N113	6" HANDLE	161	PCX101N161	FLAT WASHERS 3/8"-19
114	PCX101N114	SET SCREW 5/16*3/8"-18P	167	PCX101N167	HANDWHEEL HANDLE
115	PCX101N115	EXTERNAL RETAINING RING S13	170	PCX101N170	KNOB BOLT 3/8" *1 1/4"
116	PCX101N116	BALL	171	PCX101N171	HEX BOLT 5/16-18P*1"
120	PCX101N120	PINION GEAR	172	PCX101N172	ANGLE ADJUSTMENT PLANE
122	PCX101N122	FLAT WASHER 5/16"-20	173	PCX101N173	HEX BOLT 1/-*1/2"
123	PCX101N123	HEX BOLT 5/16*2"	174	PCX101N174	BUSHING
124	PCX101N124	BLADE COVER	175	PCX101N175	NYLON NUT 5/16"
133	PCX101N133	CAP SCREW 1/4*7/8"-20P	176	PCX101N176	ADJUSTMENT BAR BRACKET
134	PCX101N134	GUIDE POST	B1	PCX101NB1	SUPPORT BRACKET CAST IRON 7/8" ID
135	PCX101N135	POINTER	B2	PCX101NB2	SUPPORT BEARING SHAFT
136		PHILLIPS HEAD SCREW 3/16"-24P1/4"	B3	PCX101NB3	BEARING 6200ZZ
139	PCX101N139	TABLE PIN	B4	PCX101NB4	EXTERNAL RETAINING RING S10
140	PCX101N140	MITER GAUGE ASSY	B5	PCX101NB5	SET SCREW 1/4-20P*1/4"
141	PCX101N141	TABLE INSERT ALUMINUM	B6	PCX101NB6	HEX BOLT 1/4-20*1/2"
142A	PCX101N142A	TABLE	B7	PCX101NB7	THUMBSCREW 1/4*3/4"20P
143	PCX101N143	SCALE	B8	PCX101NB8	HEX BOLT 1/4-20P*3/8"
144	PCX101N144	POINTER PLATE	B9	PCX101NB9	FLAT WASHER 1/4"-25
146	PCX101N146	HEX BOLT 3/8-16P*2-1/2	B10	PCX101NB10	SUPPORT
147	PCX101N147	TRUNNION CLAMPSHOE	B11	PCX101NB11	LOWER SUPPORT BRACKET
148	PCX101N148	TRUNNION	B12	PCX101NB12	BEARING SHAFT (BEARING SUPPORT)
149	PCX101N149	HEX BOLT 5/16-18P*3/4"	B13	PCX101NB13	GUIDE SHAFT (L)

CX101N FENCE BREAKDOWN

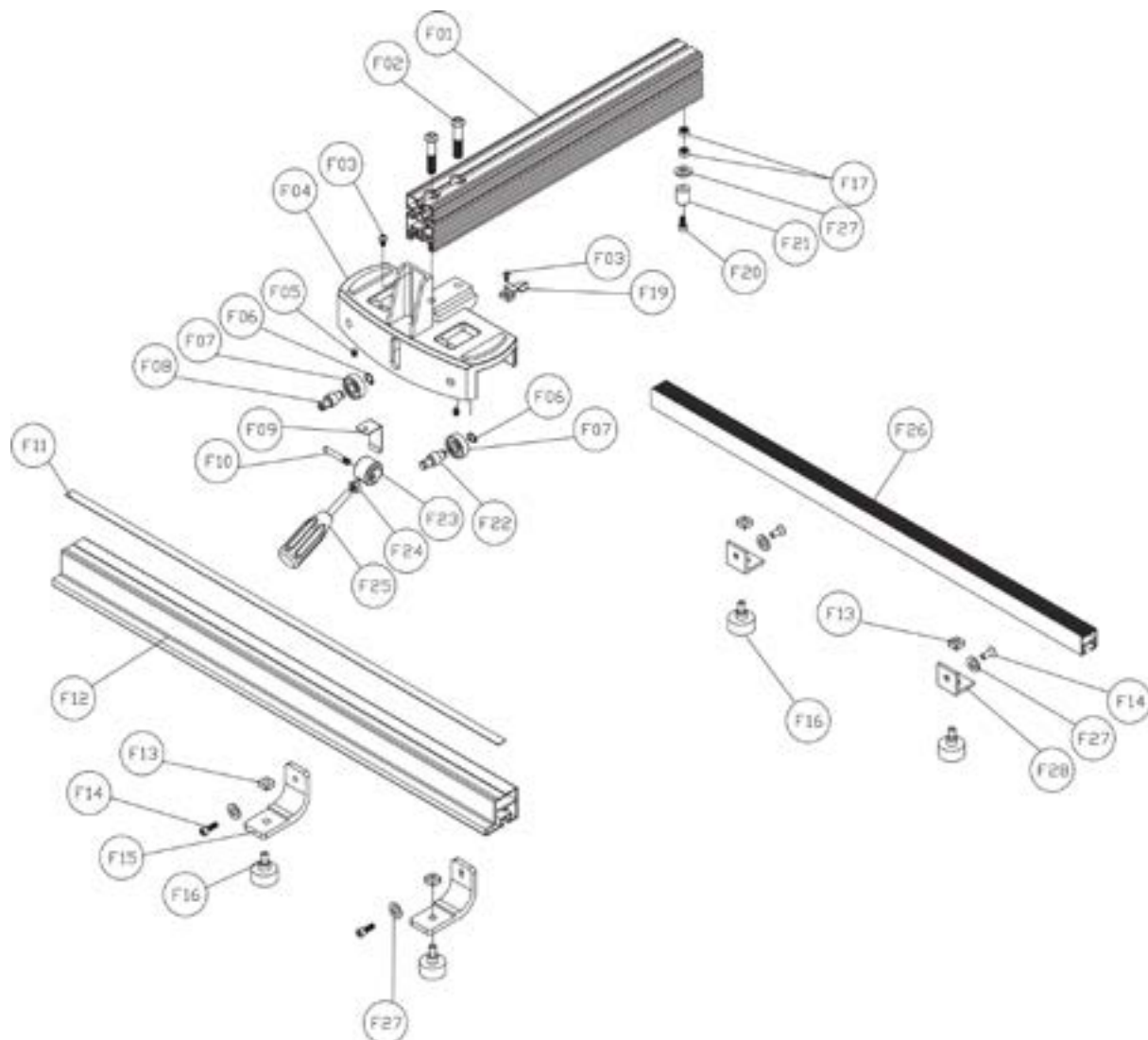

KEY	REF #	DESCRIPTION	KEY	REF #	DESCRIPTION
F01	PCX101NF01	FENCE BODY	F15	PCX101NF15	L TYPE PLATE
F02	PCX101NF02	FLAT HEAD CAP SCREW M10*25MM	F16	PCX101NF16	KNOB 5/16-18X5/8
F03	PCX101NF03	FLAT HEAD CAP SCREW M5*10MM	F17	PCX101NF17	HEX NUT M6
F04	PCX101NF04	FENCE BASE	F19	PCX101NF19	POINTER
F05	PCX101NF05	SET SCREW 1/4-20P*1/4"	F20	PCX101NF20	SOCKET HEAD CAP SCREW M6*16mm
F06	PCX101NF06	EXTERNAL RETAINING RING S10	F21	PCX101NF21	RUNNER
F07	PCX101NF07	BEARING 6200ZZ	F22	PCX101NF22	BEARING SHAFT
F08	PCX101NF08	ECCENTRIC SHAFT	F23	PCX101NF23	LOCK MECHANISM
F09	PCX101NF09	PRESSURE PLATE	F24	PCX101NF24	HEX NUT 8MM-1.25P
F10	PCX101NF10	PIN	F25	PCX101NF25	FENCE HANDLE
F11	PCX101NF11	FENCE SCALE	F26	PCX101NF26	REAR RAIL
F12	PCX101NF12	FRONT FENCE RAIL	F27	PCX101NF27	FLAT WASHER
F13	PCX101NF13	SQUARE NUT	F28	PCX101NF28	L BRACKET
F14	PCX101NF14	HEX BOLT 1/4"*5/8"			



WARRANTY

CRAFTEX 3 YEARS LIMITED WARRANTY

Crafter warrants every product to be free from defects in materials and agrees to correct such defects where applicable. This warranty covers **three years** for parts and 90 days for labour (unless specified otherwise), to the original purchaser from the date of purchase but does not apply to malfunctions arising directly or indirectly from misuse, abuse, improper installation or assembly, negligence, accidents, repairs or alterations or lack of maintenance.

Proof of purchase is necessary.

All warranty claims are subject to inspection of such products or part thereof and Crafter reserves the right to inspect any returned item before a refund or replacement may be issued.

This warranty shall not apply to consumable products such as blades, bits, belts, cutters, chisels, punches etceteras.

Crafter shall in no event be liable for injuries, accidental or otherwise, death to persons or damage to property or for incidental contingent, special or consequential damages arising from the use of our products.

RETURNS, REPAIRS AND REPLACEMENTS

To return, repair, or replace a Crafter product, you must visit the appropriate Busy Bee Tools showroom or call 1-800-461-BUSY. Crafter is a brand of equipment that is exclusive to Busy Bee Tools. For replacement parts directly from Busy Bee Tools, for this machine, please call 1-800-461-BUSY (2879), and have your credit card and part number handy.

- All returned merchandise will be subject to a minimum charge of 15% for re-stocking and handling with the following qualifications.
- Returns must be pre-authorized by us in writing.
- We do not accept collect shipments.
- Items returned for warranty purposes must be insured and shipped pre-paid to the nearest warehouse
- Returns must be accompanied with a copy of your original invoice as proof of purchase. Returns must be in an un-used condition and shipped in their original packaging a letter explaining your reason for the return. Incurred shipping and handling charges are not refundable.
- Busy Bee will repair or replace the item at our discretion and subject to our inspection.
- Repaired or replaced items will be returned to you pre-paid by our choice of carriers.
- Busy Bee reserves the right to refuse reimbursement or repairs or replacement if a third party without our prior authorization has carried out repairs to the item.
- Repairs made by Busy Bee are warranted for 30 days on parts and labour.
- Any unforeseen repair charges will be reported to you for acceptance prior to making the repairs.
- The Busy Bee Parts & Service Departments are fully equipped to do repairs on all products purchased from us with the exception of some products that require the return to their authorized repair depots. A Busy Bee representative will provide you with the necessary information to have this done.
- For faster service it is advisable to contact the nearest Busy Bee location for parts availability prior to bringing your product in for repairs.

