



# CX108N

## 18" WOOD BAND SAW

### User Manual



# TABLE OF CONTENTS

General Safety Instructions .....	3
Specific Safety Instructions .....	4
Features .....	5
Physical Features .....	6
<b>Setup .....</b>	<b>7</b>
Un-packing .....	7
Proper Grounding .....	8
<b>Assembly and Adjustments .....</b>	<b>9</b>
Blade Tracking .....	12
Basic Controls .....	13
Test Run .....	13
Blade Tension .....	14
Adjusting the Blade Tension .....	14
Guide Bearings Adjustments .....	14
Table Stop Adjustment .....	15
Table Tilt Scale Calibration .....	16
Table Alignment .....	16
Guide Post .....	17
Work-Piece Inspection .....	17
Cast Iron Wheels .....	18
Coplanar Adjustment .....	18
<b>Operations .....</b>	<b>19</b>
Ripping .....	19
Cross Cutting .....	19
Re-Sawing .....	20
Cutting Curves .....	20
Connecting to a Dust Collector .....	20
<b>Maintenance .....</b>	<b>21</b>
Removing/Installing Blade .....	21
Blade and Table Alignments .....	21
Tilting the Table Backward .....	22
Table and Base .....	22
V-Belts .....	22
Removing/Replacing the V-Belts .....	23
Parts Breakdown and List .....	24-30
Warranty .....	31

# GENERAL SAFETY INSTRUCTIONS

**Extreme caution should be used when operating all machinery. Know your machine, be familiar with its operation, read through the owner's manual and practice safe usage procedures at all times.**

- ❖ **ALWAYS** read and understand the user manual before operating the machine.
- ❖ **CONNECT** your machine **ONLY** to the matched and specific power source.
- ❖ **ALWAYS** wear safety glasses respirators, hearing protection and safety shoes, when operating your machine.
- ❖ **DO NOT** wear loose clothing or jewelry and secure long hair in a net or tied back when operating your machine.
- ❖ **A SAFE ENVIRONMENT** is important. Keep the area free of dust, dirt and other debris in the immediate vicinity of your machine.
- ❖ **BE ALERT! DO NOT** use prescription or other drugs that may affect your ability or judgment to safely use your machine.
- ❖ **DISCONNECT** the power source when changing blade and / or making adjustments.
- ❖ **NEVER** leave a tool unattended while it is in operation.
- ❖ **NEVER** reach over the table when the tool is in operation.
- ❖ **ALWAYS** keep blades, knives and bits sharpened and properly aligned.
- ❖ **ALL OPERATIONS MUST BE** performed with the guards in place to ensure safety.
- ❖ **ALWAYS** use push sticks to safely feed your work through the machine.
- ❖ **ALWAYS** make sure that any tools used for adjustments are removed before operating the machine.

## CX108N - 18" Wood Bandsaw

# SPECIFIC SAFETY INSTRUCTIONS

- ❖ **CX108N** is perfect for cutting various types of wood.
- ❖ **ALWAYS INSPECT** the blade for any cracked or missing teeth before operating the band saw.
- ❖ **ALWAYS ENSURE** that the blade tension is properly set for the type and width of blade installed.
- ❖ **NEVER** place your fingers or hands in the line of cut. If you slip, your hands or fingers may come into contact with the blade. Always use a push stick when ripping narrow pieces.
- ❖ **DO NOT** back the work-piece away from the blade while cutting. Always turn off the machine if you are backing out a cut. ALL GUARDS must be in place while operating the band saw to ensure safety.
- ❖ **ALWAYS FEED** the stock smoothly. Do not force or twist the work-piece while cutting.
- ❖ **ALWAYS ENSURE** that the band saw blade guard is no more than 1/2" above the stock.
- ❖ **MAKE SURE** before making any adjustments, the switch is in the **"OFF"** position and the cord is un-plugged from the power source.
- ❖ **NEVER LEAVE** the band saw unattended while it is running.
- ❖ **DO NOT** attempt to remove jammed pieces unless the band saw has come to a complete stop and the power switch has been turned to the **OFF** position.
- ❖ **NEVER TURN ON** the band saw if the blade is in contact with your workpiece.
- ❖ **ALWAYS ENSURE** that the guide bearings are properly set to prevent blade wander.
- ❖ **ALWAYS MAKE CERTAIN** that the guide bearings are properly adjusted to guide the blade properly.
- ❖ **MAINTAIN AND SERVICE** your band saw regularly as instructed in the user manual.
- ❖ **MAKE SURE** you have read and understood all the safety instructions in the manual and you are familiar with your band saw, before operating the **CX108N**. If you fail to do so, serious injury could occur.

### WARNING

The safety instructions given above can not be complete because the environment in every shop is different. Always consider safety first as it applies to your individual working conditions.

## CX108N - 18" Wood Bandsaw

# FEATURES

As part of the growing line of Craftex woodworking & metalworking equipment, we are proud to offer the CX108N - 18" Variable Speed Band Saw. The Craftex name guarantees Craft Excellence. By following the instructions and procedures laid out in this user manual, you will receive years of excellent service and satisfaction. The CX108N is a professional tool and like all power tools, proper care and safety procedures should be adhered to.

- ⊠ Motor ..... 2HP, 220V Single Phase, 3450 RPM
- ⊠ Switch ..... Magnetic Switch
- ⊠ 3 Speed ..... 1480, 2300 & 3260 FPM
- ⊠ Cast Iron Table Size ..... 20" x 24
- ⊠ Table Tilt ..... 0° to 10° Left and 0° to 45° Right
- ⊠ Wheel ..... 18"
- ⊠ Max Blade Width ..... 1"
- ⊠ Min Blade Width ..... 1/8"
- ⊠ Maximum Cutting Height ..... 12"
- ⊠ Floor to Table Height.. ..... 38-1/2"
- ⊠ Cutting Capacity/Throat.. ..... 17-5/8"
- ⊠ Dust Collection Ports ..... 2 Ports@ 4"
- ⊠ Blade Length ..... 133"
- ⊠ Bearings ..... Sealed and Permanently Lubricated
- ⊠ Computer Balanced Cast Iron Wheels ..... .Yes
- ⊠ Co-Planer Adjustment ..... Yes
- ⊠ Powder Coated Paint ..... Yes
- ⊠ Precision Ripping Fence ..... Yes
- ⊠ Quick Release Tension Adjustment .... Yes
- ⊠ Overall size ..... 30" x 41" x 74"
- ⊠ Carton Size ..... 32" x 76" x 19"
- ⊠ Weight.. ..... 173 GW
- ⊠ Warranty ..... 3 Years

# CX108N - 18" Wood Bandsaw

## PHYSICAL FEATURES



## Setup

Before setting up your machine you need to read and understand this user manual completely.

The unpainted surfaces of this band saw are coated with a rust preventive waxy oil and you will want to remove this before you begin assembly. Use a solvent cleaner that will not damage painted surfaces. amount of cleaner/degreaser, then let it soak for 5-10 minutes.

### WARNING

CX108N is a heavy machine. Do not over-exert yourself. Use a fork truck or get the help of an assistant or a friend.

## Unpacking

The machine is properly packaged in a carton for safe transportation. When unpacking, carefully inspect the crate and ensure that nothing has been damaged during transit. Open the crate and check that the machine is in good condition.

The hardware (screws, washers etc) might be shipped in a plastic bag. After the machine has been un-packed, check that all loose parts and hardware are present.

## List of Contents

<b>A.</b> Allen Keys 2, 3mm .....	2
<b>B.</b> Wrench .....	1
<b>C.</b> 1/4" Lock Washer .....	2
<b>D.</b> Flat Washer 5/16" .....	1
<b>E.</b> 1/4" Lock Washer .....	2
<b>F.</b> Flat Washer .....	1
<b>G.</b> Knob Bolt 3/8-16 x 1 1/4 .....	1
<b>H.</b> Hex Bolt 5/16-18x1 .....	1
<b>I.</b> Angle Adjustment Plane .....	1
<b>J.</b> Hex Bolt 1/4-20x1/2 .....	2
<b>K.</b> Bushing .....	1
<b>L.</b> Nylon Nut 5/16-18 .....	1
<b>M.</b> Adjustment Bar Bracket .....	1
<b>N.</b> Square Nut 5/16 .....	4

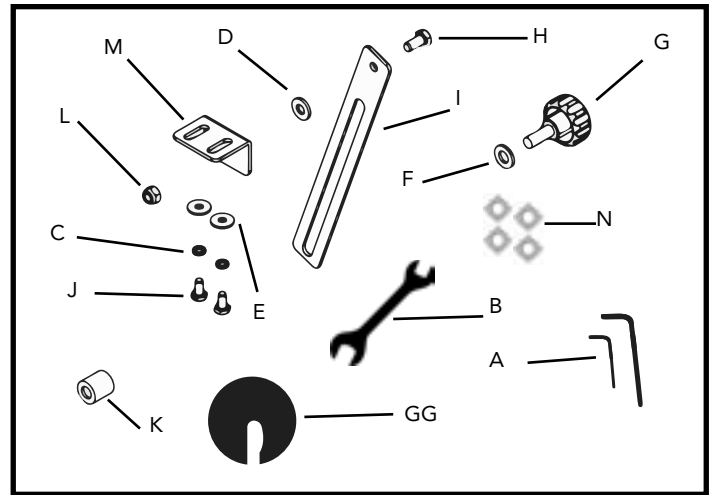

Figure-1 Inventory

## List of Contents

<b>O.</b> Flat Washer 1/4"-16 1.2mm .....	4
<b>P.</b> Hex Bolt 1/4"*5/8" .....	4
<b>Q.</b> Miter Gauge Holder .....	1
<b>R.</b> Fence Holder .....	1
<b>S.</b> Miter Gauge .....	1
<b>T.</b> Scale (for the front rail) .....	1
<b>U.</b> Fence Assembly .....	1
<b>V.</b> Front Rail .....	1
<b>W.</b> Rear Rail .....	1
<b>X.</b> Front Rail Brackets .....	2
<b>Y.</b> Rear Rail Brackets .....	2
<b>Z.</b> Front Rail Knobs .....	2
<b>AA.</b> Rear Rail Knobs .....	2
<b>BB.</b> Flat Washers 3/8" .....	2
<b>CC.</b> Knobs 3/8"-16 .....	2
<b>DD.</b> Hex Bolts 1/4"-20x1/2" .....	2
<b>EE.</b> Lock Washer 1/4" .....	2
<b>FF.</b> Flat Washers 1/4" .....	2
<b>GG.</b> Table Insert.....	1

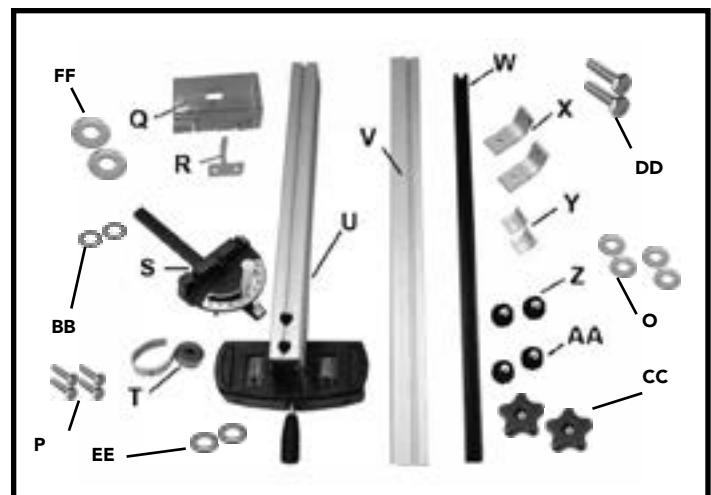

Figure-2 Inventory

## Proper Grounding

Grounding provides a path of least resistance for electric current to reduce the risk of electric shock.

CX108N is equipped with a 220 single phase motor which features a 3-conductor cord and a 3-prong grounded plug to fit a grounded type receptacle. Make sure the cord is plugged into a properly installed and grounded power outlet.

To prevent electrical hazards, have a qualified electrician ensure that the line is properly wired.

This machine is for use on a normal 220-volt circuit and is factory-equipped with a specific electric cord and plug to permit connection to a proper electric circuit. Make sure that the machine is connected to an outlet having the same configuration as the plug. If an adapter plug is used, it must be attached to the metal screw of the receptacle.

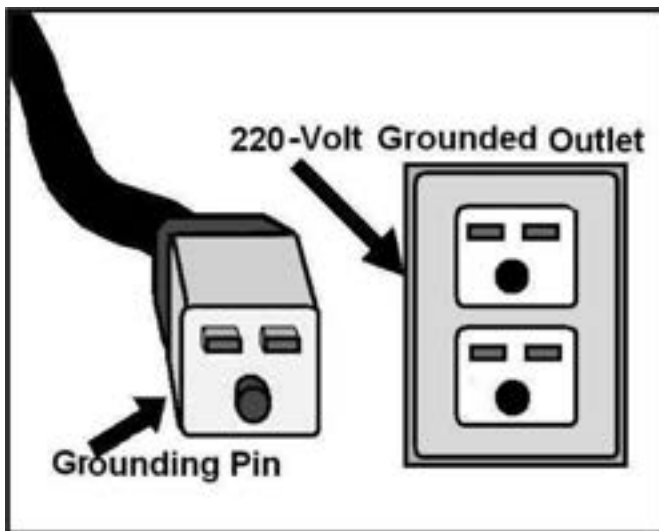

Figure-3 220-Volts Outlet for CX108N



### **WARNING**

Improper connection of the equipment-grounding conductor can result in a risk of electric shock. Check with a qualified electrician if you are in doubt as to whether the outlet is properly grounded.

It is strongly recommended not to use extension cords with your CX108N. Always try to position your machine close to the power source so that you do not need to use extension cords.

In case if you really find it necessary to use an extension cord, make sure the extension cord does not exceed 50-feet in length and the cord is 12-gauge to prevent motor damage.

Your CX108N is equipped with a cord having 3-prongs which fits a 3 prong grounded receptacle as shown in figure-3. Do not remove the grounding prong to fit it into a 2-pronged outlet. Always check with a qualified electrician if you are in doubt.



## Assembly

Follow the steps below to assemble your band saw:

Take the band saw table and put it upside down on floor and make sure that all the table bolts shown in the figure are tight. See figure-4

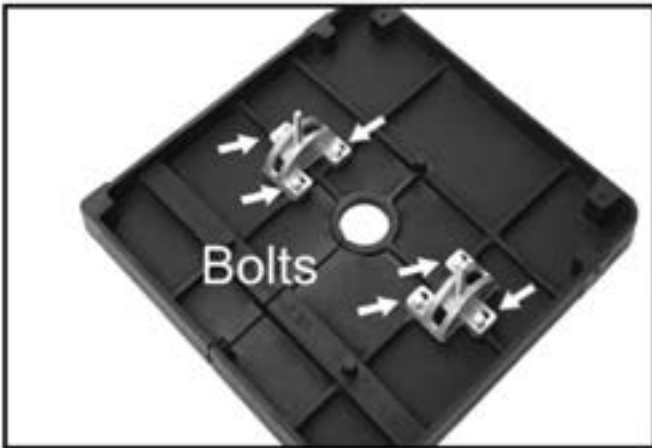

Figure-4 Table Turnion bolts

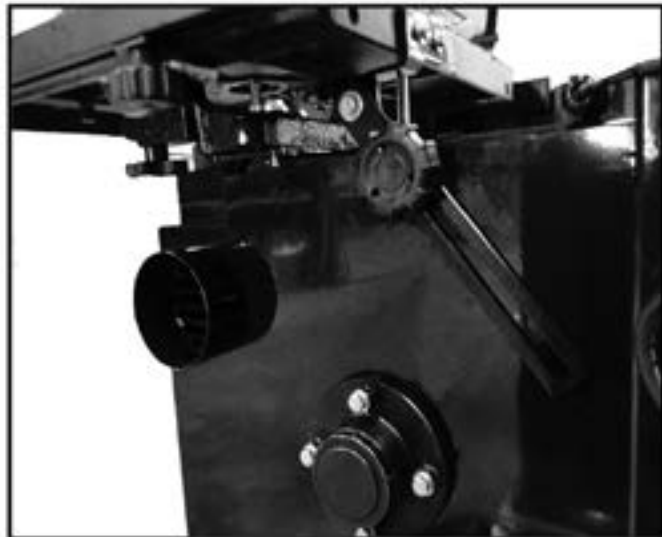

Figure-5 Installing the angle adjustment brackets

Attach the Adjustment bar bracket #176 to the underside of the table using the 2 screws #173 and the washers, #17, and #103. Secure the Angle adjustment plane #172 to the adjustment bar bracket #176 with the hex bolt #171, washer #122 and the locking nut #175.

Now turn the table up right, and remove the table pin from the table slot and the table insert (if already installed) and move the table in position around the blade, guiding through the table slot. See figure-6



Figure-6 Installing the table

Position the table on the base in such a way that the bolts under the table extend through the holes on the base. Thread the two knobs on the bolts ( do not tighten). See figure-7

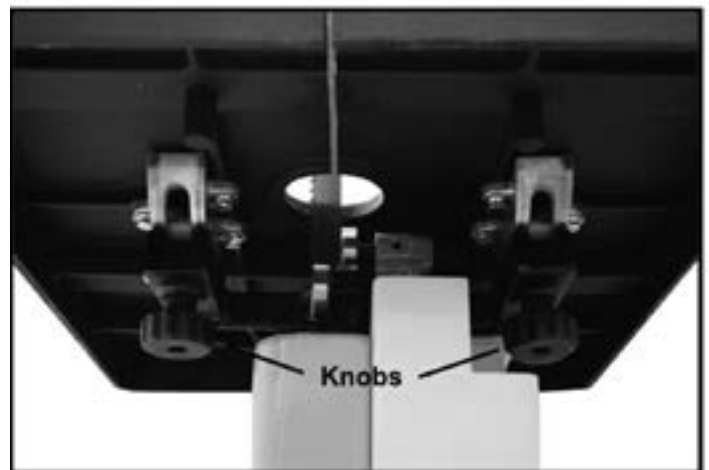

Figure-7 Knobs threaded on the bolts

Position the table on the table stop and the base so that the table is perpendicular to the blade. See page 15 for details.

Place the washer #60 on the knob #170. Pass the threaded stud of the knob through the slot in the angle adjustment plane. Then install the spacer on the threaded stud of the knob and then thread the knob into the body of the band saw.

Tighten the knob to secure the table at the desired angle required for your cutting operation.

Install the table insert at the center of the table and the table pin into the table slot as shown in figure-8.

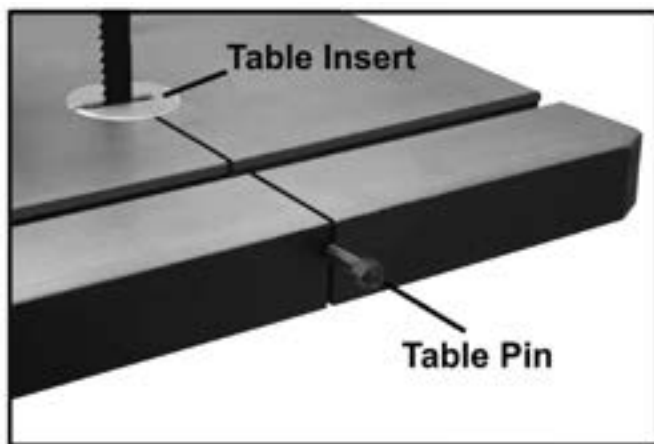

Figure-8 Installing table insert and table pin

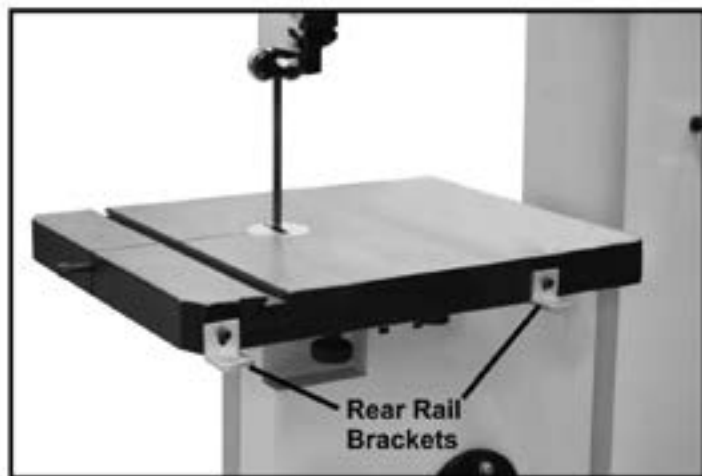

Figure-9 Rear rail brackets attached

Now, attach the rear rail to the brackets using the knobs provided. See figure-11.

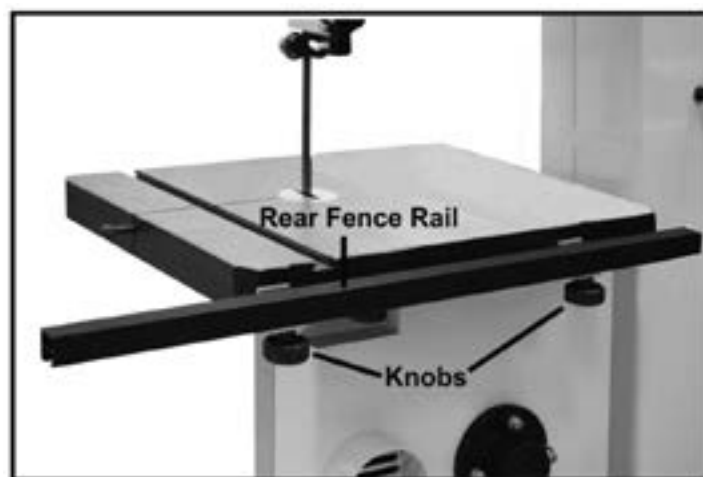

Figure-10 Installing the rear fence rail

Take the rail bracket (smaller) and attach it to the table using cap screws provided. See figure-9 .

Take the rail brackets (larger) for the front fence rail and attach it to the table using the cap screws provided.

Place the front fence rail on the brackets and insert the knobs through the hole on each bracket and thread the square nuts onto the ends of the knobs a couple of turns to tighten the fence rail in place. See figure-11.

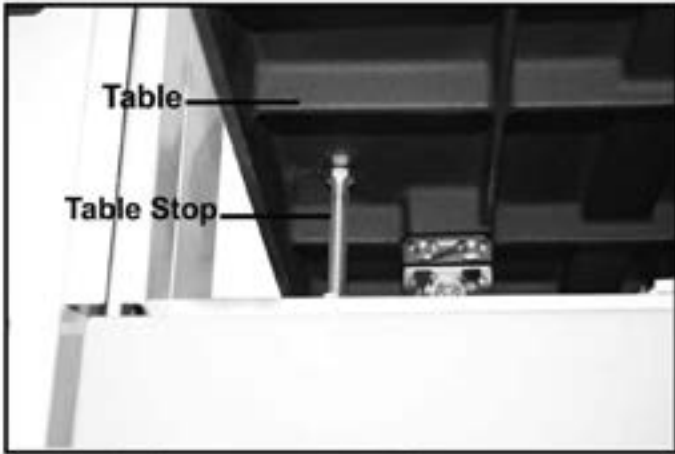

Figure-11 Front fence rail installed

Now take the fence and lift up the handle. Place the fence on the front fence rail until it touches against the blade.

Use a pencil to mark the fence rail where the fence scale indicator on the right hand side is pointing (there is a gap just behind the indicator plate where you can mark the rail). This mark will indicate where to align the 0" mark when install the scale.

Now, remove the fence from the rail and install the adhesive backed scale on the front fence rail.



Figure-12 Adhesive backed scale attached to the front rail

Once you have attached the adhesive backed scale to the rail, place the fence on the rail and tighten it in place by pushing down the handle. See figure-14

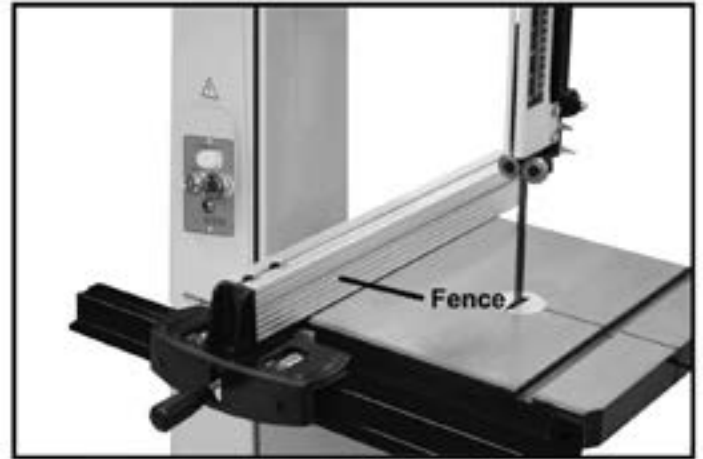

Figure-13 Fence installed on the rails

Attach the miter gauge holder and the fence holder to the back of the saw using screws and washers provided see figure-14

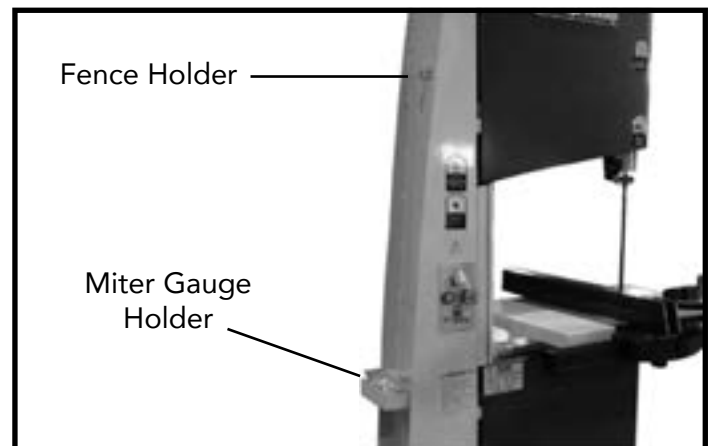

Figure-14 Miter gauge holder and fence holder installed

## Blade Tracking

Blade tracking refers to the blade remaining in the same position on the upper and lower wheels. When rotating the wheel by hand, if it moves forward or backward on the wheel then tracking needs to be adjusted.

Although the blade tracking of this band saw is factory set, you should check it again to make sure that the blade is centered on the wheels. The misalignment of the blade can be controlled by adjusting the upper wheel tilt lock nuts.

Disconnect the machine from power and open the upper wheel cover. Rotate the upper wheel by hand slowly and see how the blade rides on the wheel.

If the blade is not properly aligned and needs to be adjusted, loosen the lock nuts shown in figure-15 and turn the knobs.

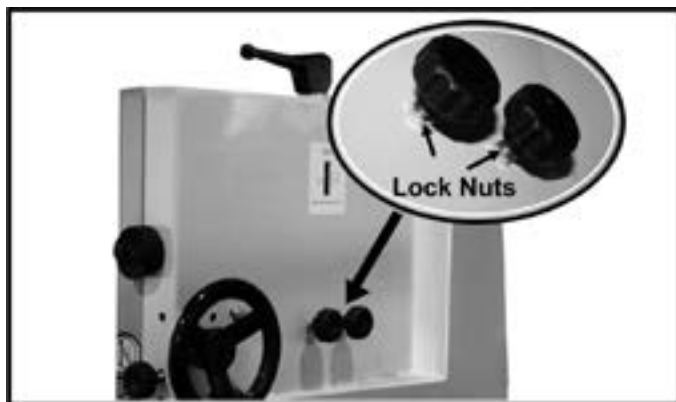

Figure-15 Knobs and Locks Nuts

### Turn the knobs clockwise:

If the blade moves towards the front edge of the wheel. It makes the top of the wheel to tilt back and moves the blade towards the center.

### Turn the knobs counter-clockwise:

If the blade moves towards the back edge of the wheel. It makes the top of the wheel

to tilt to the front and moves the blade towards the center.

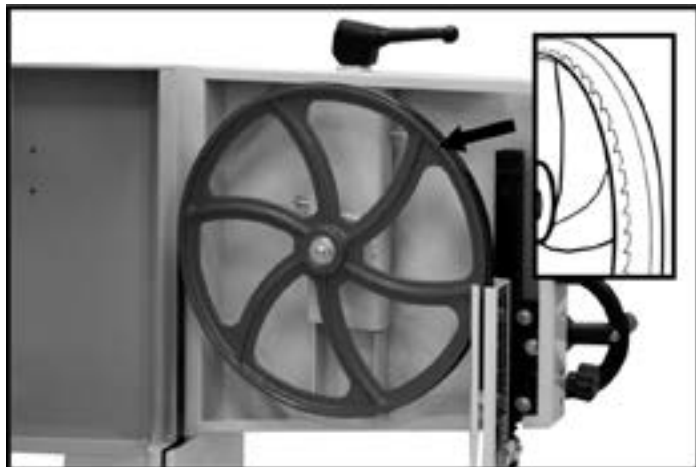

Figure-16 Blade centered on the wheel

When you have adjusted the blade tracking, re-tighten the lock nuts.

### IMPORTANT

In very rare cases if the blade tracking is not adjusted by tilting the upper wheel, then you will have to make minor adjustments to the angle of tilt of the lower wheel. Loosen the four hex bolts and rotate the sleeves to tilt the lower wheel to get the proper angle of tilt and tighten the bolts back. Remember, this adjustment is done only if the blade tracking is not adjusted by tilting the upper wheel.

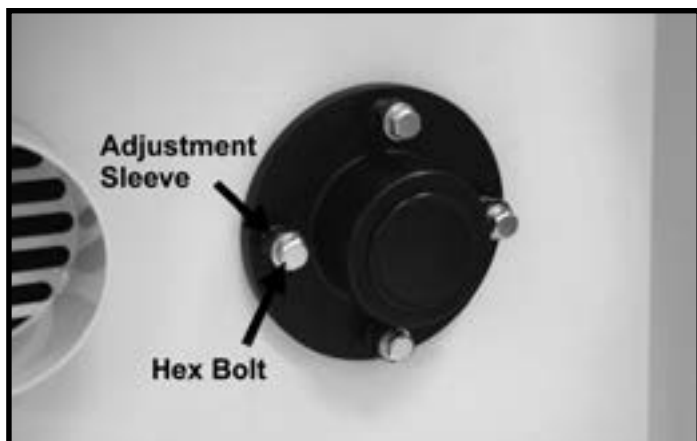

Figure-17 Lower wheel adjustment sleeves

## Basic Controls

The basic controls of this machine are shown in the figure below. Use the figure and read the text to understand what the basic controls of this band saw are.

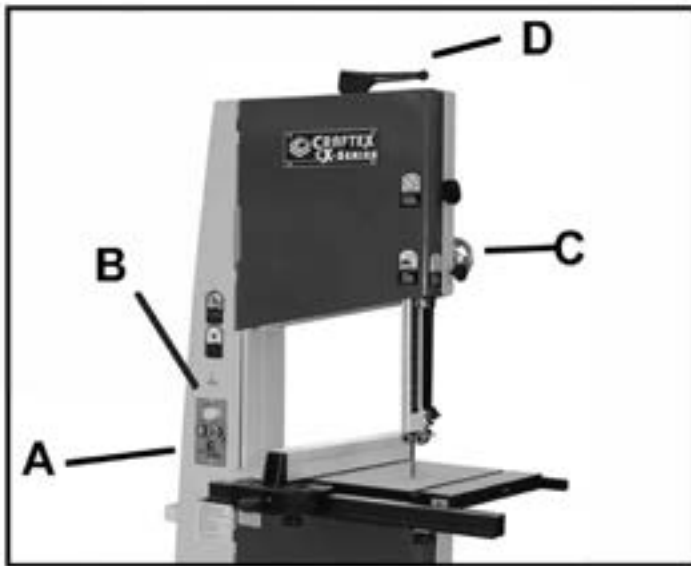

Figure-18 Basic controls of CX108N

- A.** The power switch turns the power on/off to the motor switch.
- B.** The motor switch start and stops the motor and only works after the power switch has been turned on.
- C.** The guide post hand wheel raises or lowers the post guide post.
- D.** The blade tension/ quick release lever increase or decreases blade tension when rotated. Lifting the handle activates the quick release.

## IMPORTANT

Make sure you have done the tracking adjustment and the blade is centered on the wheels before you start the band saw for a test run. See page-12 for details on blade tracking.



## WARNING

This machine can perform many types of operations which are beyond the scope of this manual and are very dangerous if performed incorrectly. The safety instructions given in this manual can not be complete because the environment in every shop is different. Always consider safety first as it applies to your individual working conditions.

## TEST RUN

Once you have assembled your machine completely, it is then time for a test run to make sure that the machine works properly and is ready for operation.

During the test run if there is any unusual noise coming from the machine or the machine vibrates strangely, stop the machine immediately and disconnect from the power source and investigate the source of the problem with your machine refer to the trouble shooting.

## READ THE MANUAL

Before starting the band saw, make sure that you have read and understood the manual and you are familiar with the functions and safety features on this machine. Failure to do so may cause serious personal injury.

## Blade Tension

A properly tensioned blade is very important to get the best performance from any band saw. If the blade is too loose there is a possibility that the blade will slip or drift off the line while in operation and it will be hard to have accuracy in the line of cut. If the blade is tensioned too tightly, it will be very difficult to make tighter radius cuts and there will be a greater possibility of blade breakage.

When using a wider blade for making straight cuts, for re-sawing or making wide radius cuts, tighter blade tension is recommended; while using narrower blades for cutting shorter stock or making tighter radius cuts, less blade tension is recommended.

The information above is just a guideline for you to understand to set the blade tension according to the cut. However, understanding the blade tension adjustment comes with practice with the machine.

Look at the blade tension scale located at the back of your band saw. The scale shows the ideal blade tension adjustment according to the width of the blade.

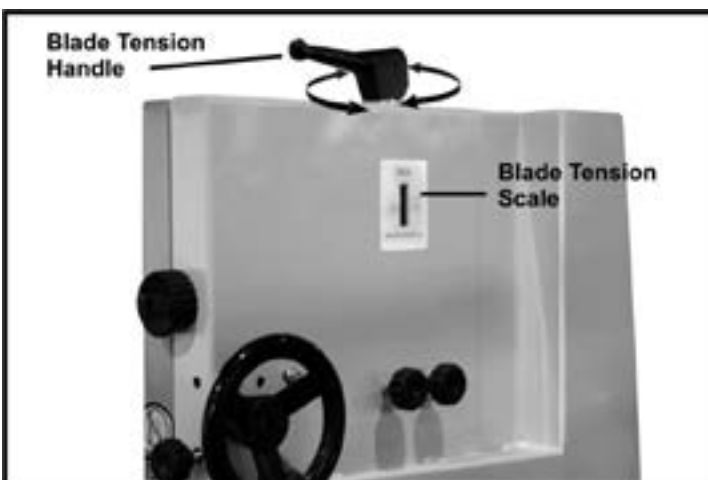

Figure-19 Quick release blade tension handle and scale

## Adjusting the Blade Tension

To adjust the blade tension, lift the blade tension handle shown in figure-19 and turn it. Turning the handle clockwise will increase the tension on the blade while turning the handle counter-clockwise will decrease the blade tension.

### IMPORTANT

All blades stretch with use, and the scale at the back of your band saw (shown in figure-19) is just an approximation. So, do not rely on any adjusted measurement for a long period of time as the blades stretch and the tension on the blade changes.

### IMPORTANT

To prolong the life of the blade and reduce blade stretching, when the machine is not in use for period of 24 hours or more release the tension on the blade.

## Guide Bearings Adjustment

The guide bearings (beside) and thrust bearing (behind) the blade, support the blade during cutting operations. Properly adjusted support bearings play, an important role in getting accurate cuts.

To adjust the guide bearings, turn the machine off and disconnect the cord from the power source and prevents the blade from wondering, therefore producing straight cuts.

Remove the blade guard and use a screw driver to loosen the screws located on each of the two guide bearings as shown in figure-20.

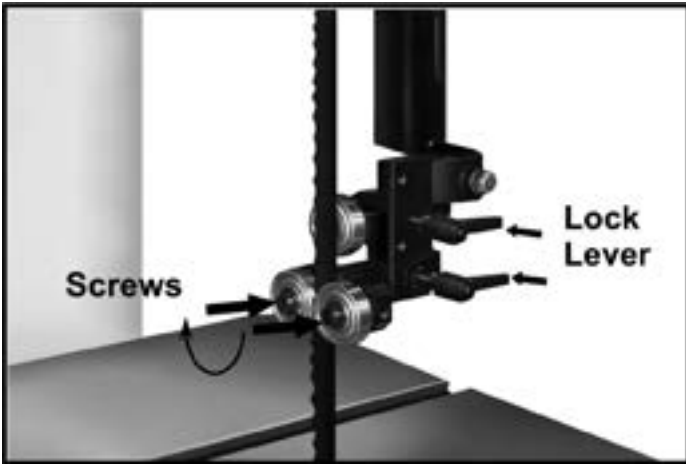

Figure-20 Set Screws

Adjust the bearings so that the space between the guide bearing and the blade should be 0.02" which is thickness of a sheet of paper. See figure-22

Now, retighten the set screws to lock the guide bearings in place. Loosen the lock levers shown in figure-23 and move the guide shafts in or out so that the guide bearings are 1/32" behind the blade gullet teeth and the thrust bearing, is 1/64" behind the back edge of the blade. Once the bearings are at the correct position behind the blade, tighten the lock lever to lock the bearings in place. See figure-23.

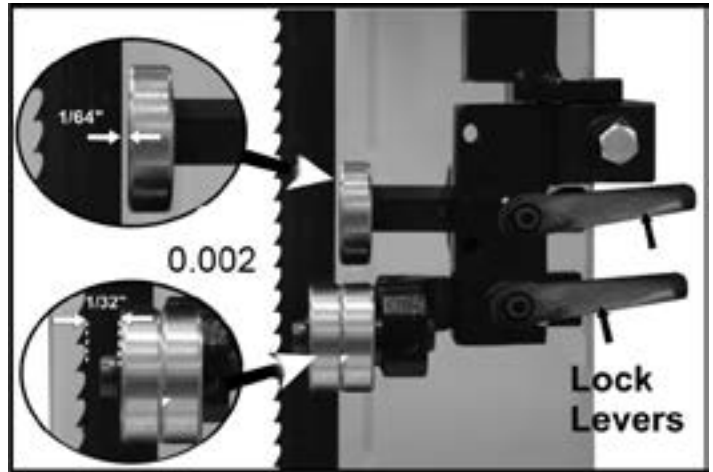

Figure-22 Distance of the bearings behind the blade.

Adjust the lower bearings in the same manner.

### Table Stop Adjustment

See figure-21 for reference.

CX108N features a table stop which allows the table to easily come to a 90° if the table is tilted.

To adjust the table stop so that the table sits at 90°, you should first make sure the switch is in "OFF" position and the power cord is unplugged. Loosen the two lock knobs under the table and loosen the hex nut which locks the table stop bolt.

Now, place a square on the table as shown in figure-23 and adjust the table stop so that the table is at a 90° with the blade.



Figure-21 Table sitting on the table stop

## Table Alignment

To make accurate cuts with your band saw, the table should be aligned properly with the blade.

To align the table:

Make sure the blade tension and tracking is done correctly. Disconnect the machine from the power source and loosen the table trunnion bolts under the table shown in figure-25.

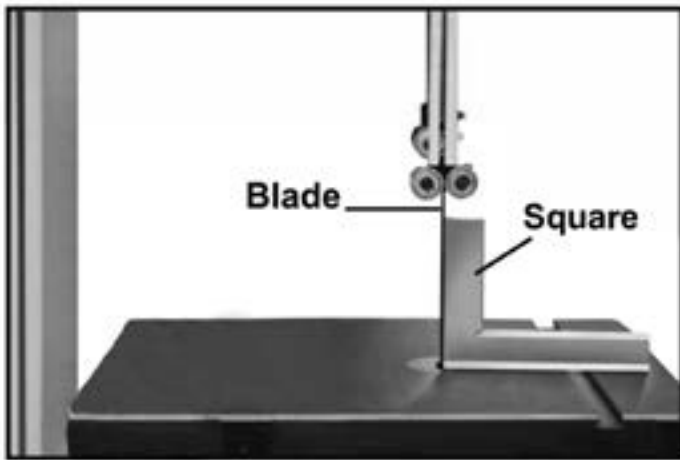

Figure-23 Adjusting the table at 90° to the table using square

Once the table is at 90° with the blade, tighten the hex nut and the knobs.

## Table Tilt Scale Calibration

To calibrate the table tilt scale:

Make sure the table is at 90° to the blade and the blade tensioning and tracking is properly set. (See Page 12 & page 14 for details)

Disconnect the machine from the power source and loosen the pointer screw shown in figure-24. Align the tip of the pointer with the 0" mark on the tilt scale and tighten the pointer screw.



Figure-24 Table tilt scale

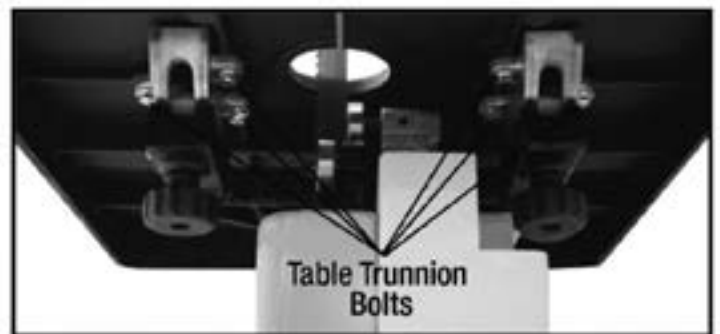

Figure-25 Table trunnion bolts

Place a straightedge on the table so that the straightedge touches the blade and is parallel to it as shown in figure-25. Make sure the straight-edge touches only the flat part of the blade, not the teeth.

Now, use a ruler to measure the distance between the miter slot and the straight edge on both sides on the table R & L. See figure-26

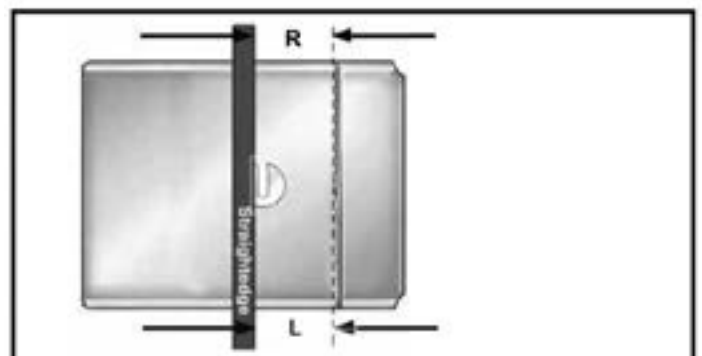

Figure-26 Aligning the table with the blade using a straight-edge



Adjust the table until the distance on both sides of the table is equal and tighten the table trunnion bolts.

## Guide Post

The guide post assembly can be moved up or down above the work-piece. The movement of the guide post is controlled with the hand wheel shown in figure-27.

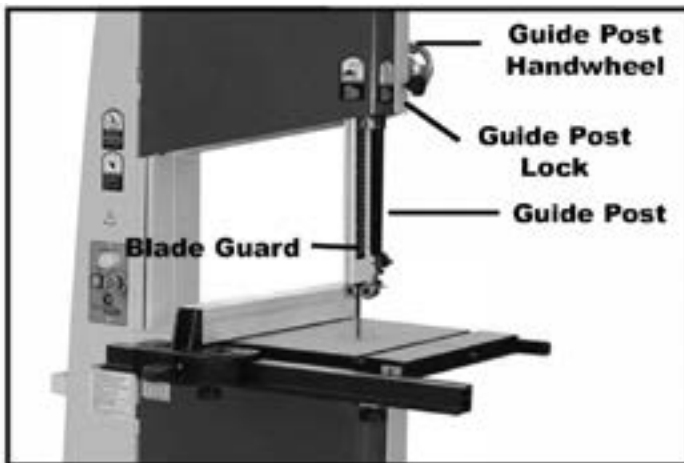

Figure-27 Guide post

To make accurate cuts and to reduce the blade slipping out of position, it is recommended to keep the guide post no more than 1" above the work-piece while cutting operation.

### To Adjust the Guide Post Assembly:

Make sure the switch is turned off and the cord is disconnected from the power source.

Loosen the guide post lock knob on your band saw shown in figure-27 and rotate the hand-wheel to move the guide post assembly up or down.

When the guide post assembly is about 1" above the work-piece, lock the guide post in place using the lock knob.

## Work-piece Inspection (Wood)

Before cutting any wood, make sure to inspect the work-piece for nails, staples, small pieces of stone or metal and any other object which might come in contact with the blade.

If the wood contains any of these objects and it comes in contact with the blade, the object might fly and hit the operator or seriously damage the blade. For a safe cutting method always inspect your workpiece carefully before cut and wear eye protection.

Some woods with excessive twisting or wrapping are un-stable while cutting and are dangerous to cut because during operation the work-piece can move unexpectedly which either damage the blade or hurt the operator.

If the wood is slightly cupped, make sure the cupped face of the wood is held against the fence. If the bowed side of the workpiece is held against the fence, the workpiece will move while cutting.



### WARNING

The information above is just a guideline for you to understand how to cut a workpiece with slight cupping. If you are not sure and do not have any experience in cutting cupped stock, do not cut it. Failure to follow these instructions might bring personal injuries to the operator or serious damage to the blade.

Some stock with large knots can damage the blade and wet stock will give a poor result.

## Cast Iron Wheels

The CX108N comes with heavy duty cast iron wheels for added stability and overall performance.

A coplanar shim adjustment also added for better alignment of the wheels that allow the blade to run as straight as possible ensuring straight and accurate cuts. This feature will help improve the band saw performance with the wheels working together instead of against each other. The end result will give you less vibration, more power, accuracy and less wandering. This will be noticed most when it comes to resawing and making straight cuts with blades larger than 1 /4".

## Coplanar Adjustment

To move the wheel out remove the nut and then remove the wheel.

Figure 28. Washer

Now you can add shims to the back of the wheels as required. Replace the wheel and any remaining shims and the nut and tighten. To move the wheel in, remove the cast iron wheel as mentioned above and remove the shims from behind the wheel. Replace the wheel, shims and nut and retighten.

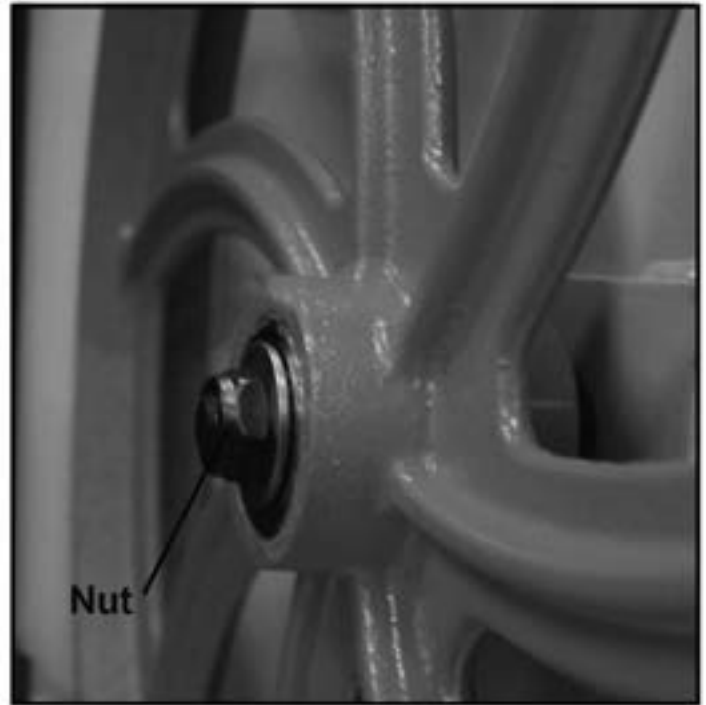

Figure-28 Washer

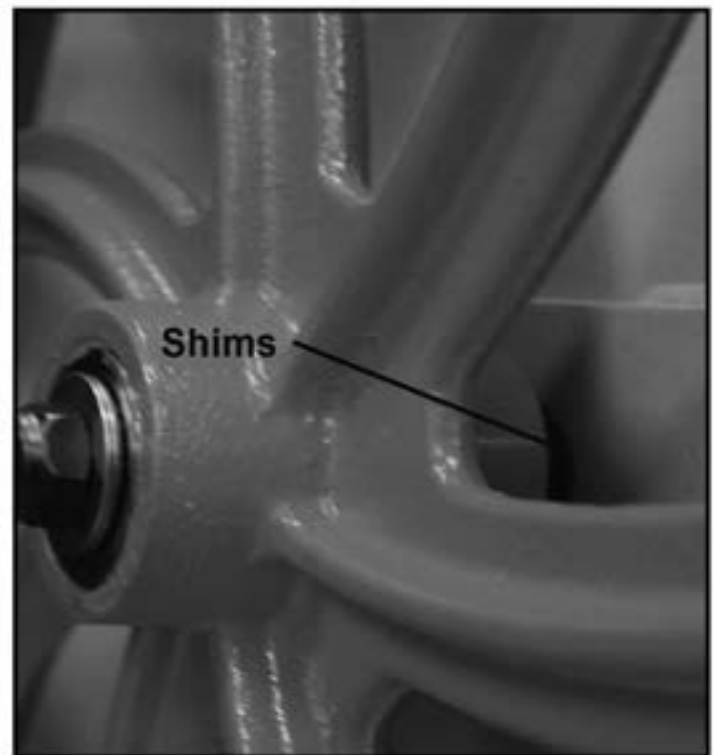

Figure-29 Top wheel back shims

## Operations

Before operating the band saw make sure you have performed the following adjustments:

- ❖ Blade tension adjustment
- ❖ Blade tracking adjustment
- ❖ Guide bearings adjustment
- ❖ Make sure all the guards are in place



### WARNING

CX108N produces fine dust particles during cutting operation which is very dangerous for health. Always connect your band saw to a dust collector.

## Ripping

Cutting solid wood with the grain cutting down the length of the work-piece is called ripping.

Adjust the fence on the rails, according to the width of the cut on the work-piece and turn the hand-wheel to set the guide post assembly 1" above the work-piece.

Now, turn the band saw ON and use a push stick to push the workpiece against the blade. See figure-30.



### WARNING

Do not use your fingers to feed narrow work-pieces into the blade. If you slip, your fingers might come close the blade. Always use a push stick.

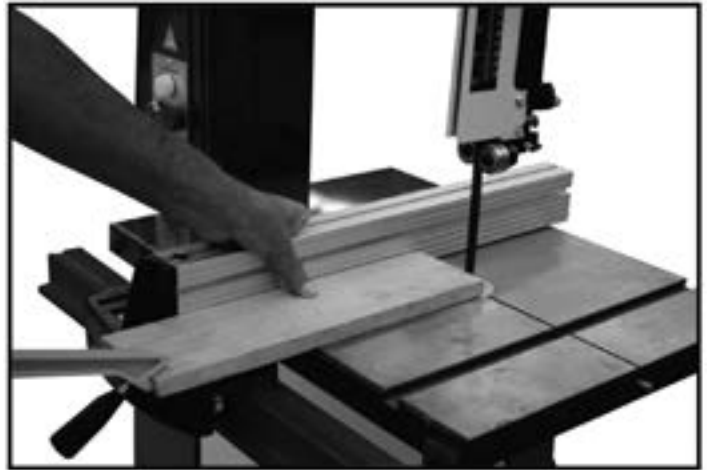

Figure-30 Ripping on CX108N

## Crosscutting

Cutting solid wood across the grain and in plywood cutting across the width of the work-piece is called crosscutting.

Mark the work-piece where you want to start the cut from and make sure the miter gauge is at 90° position on the miter slot. Place the work-piece on the table so that the marked point is aligned with the blade and hold the work-piece against the miter gauge.

Turn the band saw ON and feed the workpiece against the blade. See figure-31.

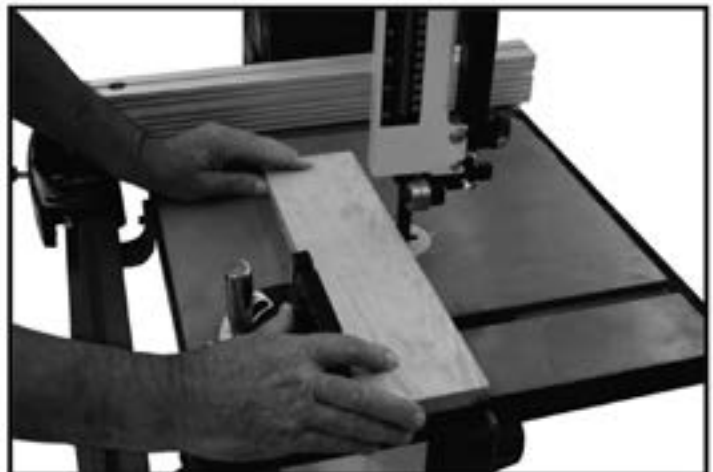

Figure-31 Crosscutting on CX108N

## Resawing

Cutting a work-piece into two or more thinner pieces is called resawing. Wider blades give better result, when resawing.

To resaw a work-piece make sure that the table is at a 90° with the blade and use a wider blade for better results.

Adjust the fence according to the width of the cut you want, and lock it in position. Turn the band saw ON and feed the workpiece into the blade using feed paddles until the blade is completely through the workpiece.

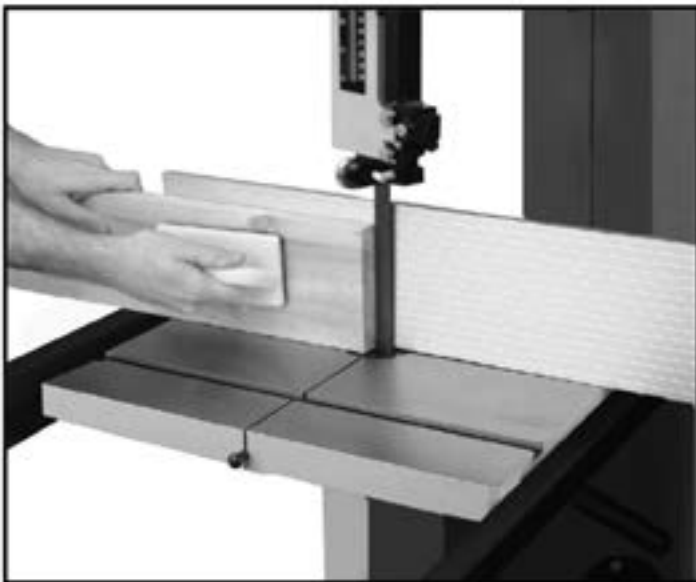

Figure-32 Resawing on CX108N

## Cutting Curves

For cutting curves always try to use narrower blades. When cutting curves feed the stock into the blade and turn it very carefully so that the blade follows the line of cut and make sure the blade does not twist.

Make relief cuts through the waste part of the work-piece which makes the job easier and prevents the blade from twisting.

## Connecting to a Dust Collector

CX108N features two 4" diameter dust ports to connect to a dust collector.

When connecting to a dust collector, use a proper sized hose and make sure all the connections are sealed tightly.

You should use a dust collector with at least a 500 CFM rating.

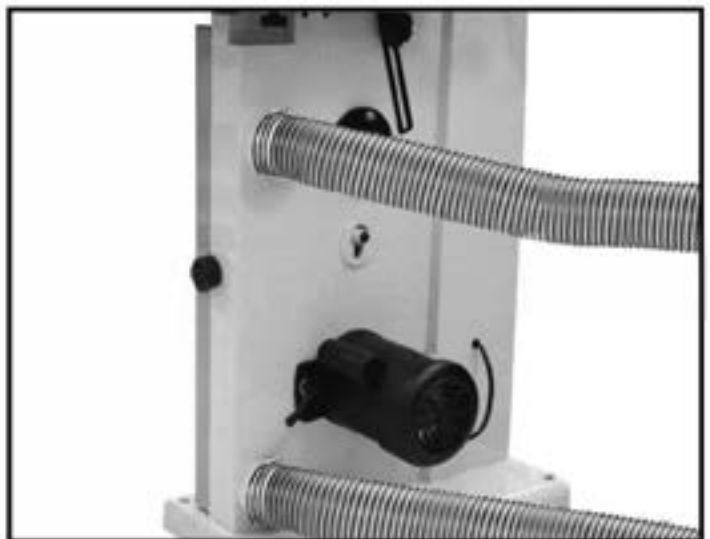

Figure-33 CX108N connected to dust collector



### **WARNING**

The saw dust produced by the band saw can go into your lungs and cause serious health problems. Make sure the band saw is connected to a dust collection system while operating it.

## Maintenance

During the life of your machine, you will need to practice some regular maintenance to keep your saw in peak performance condition.

### Removing the Blade

To remove / change the blade, turn the switch OFF and disconnect the cord from the power source.

Release the blade tension lever, and remove the table insert and the table pin.

Open the upper and lower wheel cabinets and carefully slide the blade off of both wheels.

Now, slide the blade out, through the slot on the table.

### To install the new blade

Once the old blade is removed, carefully slide in the new blade through the slot on the table so that the teeth of the blade are pointing downwards.

Position the blade through the upper and lower guide bearings and install it over the wheels.

Check the blade tracking (See page-12) and adjust the guide bearings (See page-14).

Once the blade is in the proper position, turn the tension lever to tension the blade.



Figure-34 Installing the new blade

Close the top and bottom cabinets and re-insert the table pin and table insert into the table.



### WARNING

When installing / removing and servicing any part of the machine, make sure the power switch is in the off position and the cord is disconnected from the power source. Failure to do so may result in serious personal injury or death.

### Blade and Table Adjustment

The blade and table alignments should often be checked, and make sure the blade is at a 90° with the table.

See page-16 "Table Alignment" for details.

## Tilting the Table Backward

To tilt the table backward, you will need to loosen the bolts shown in figure-35 and adjust them as needed using a wrench.

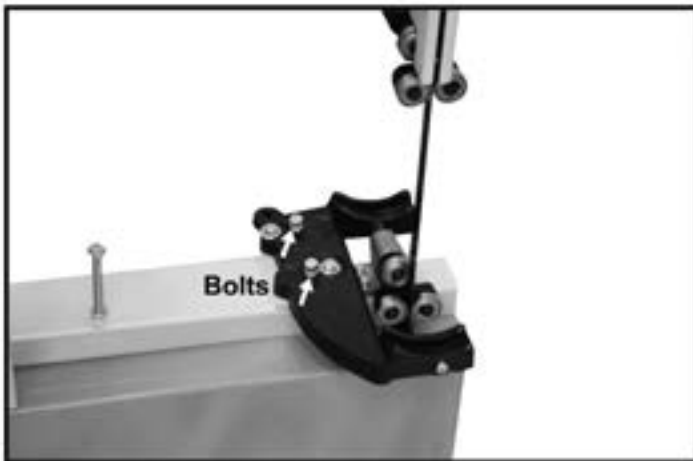

Figure-35 Bolts to tilt the table backward

## Table and Base

The moisture from the wood dust remains on the table surface and can cause rust. Protect the un-painted cast iron surfaces of the table by cleaning the table after every use or apply a protective coating.

If the table becomes harder to tilt, remove the table and apply a few drops of oil on the trunnions.

## V-Belts

The V-belts stretch with use, and should be re-tensioned periodically. To ensure optimum power transfer from the motor to the blade, the belt must be in good condition and under proper tension.

Check the V-belts at least after every 3 months and more often if the band saw is used daily.

## To Inspect the V-Belts

1. Turn the power switch off and disconnect the cord from the power source.
2. Lift the blade tension handle up and release the tension.
3. Open the lower and upper cabinet and remove the blade. (See page-21 Removing/Changing the Blade)
4. Remove the lower wheel by removing the hex bolt securing the wheel to the saw body. See figure-36.
5. Once the wheel is removed, you will have access to the V-belts. Check if the V-belts are in good condition and properly tensioned.

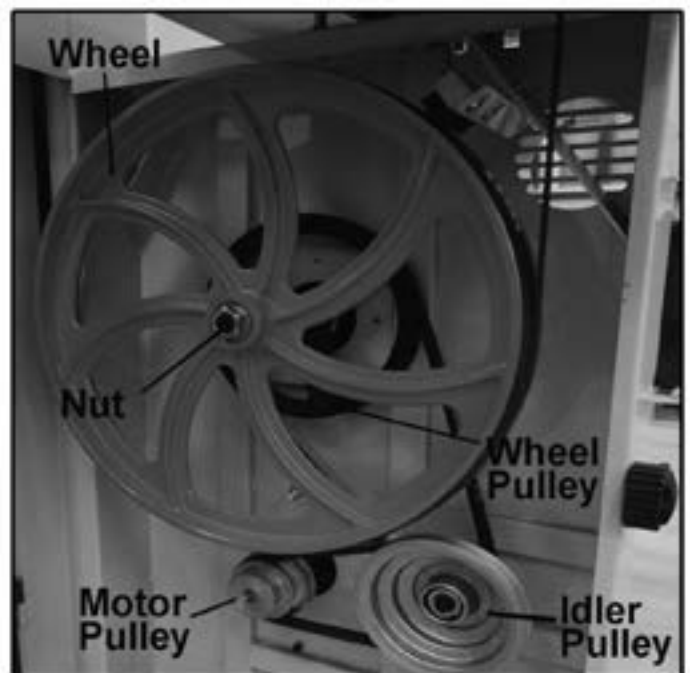

Figure-36 Lower wheel and pulleys

## To Replace the V-Belts

Follow the instructions 1-5 to access the V-belts.

6. Loosen the motor lock lever shown in figure-38 and idler pulley mounting nut shown in figure-39.



Figure-38 Motor lock lever

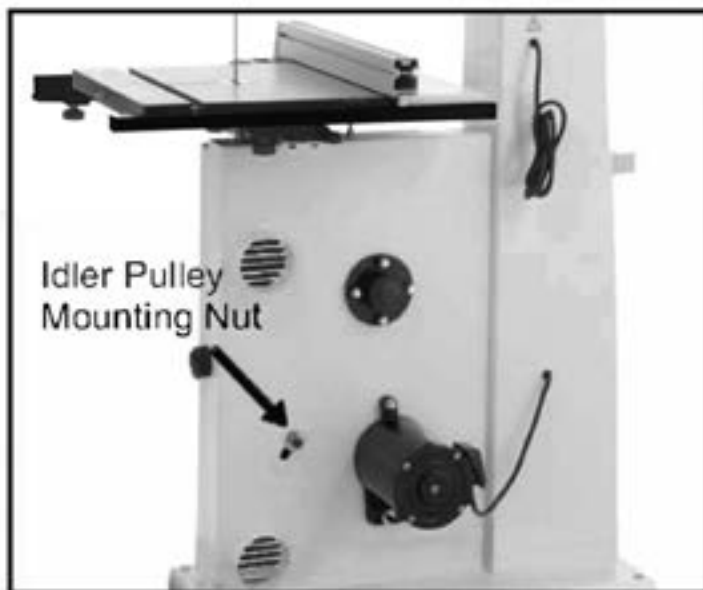

Figure-39 Idler pulley mounting nut

7. Pivot the motor and slide the idler pulley to loosen up the belt.
8. Remove the old belt and install the new one.
9. Slide the idler pulley down to tighten the lower wheel V-belt. Keep pressure on the idler pulley and tighten the mounting nut.
10. Check the wheel pulley V-belt if tensioned properly. If tension is necessary, pivot the motor to tighten the motor V-belt. Keep pressure on the motor and tighten the motor adjustment bolt.
11. Check the motor V-belt, if properly tensioned and tighten the motor hinge bolt.
12. Install back the wheel, blade and close the cabinets.



### WARNING

When installing or removing and servicing any part of the machine, make sure the power switch is in the off position and the cord is disconnected from the power source. Failure to do so may result in serious personal injury or death.

# CX108N PARTS DIAGRAM

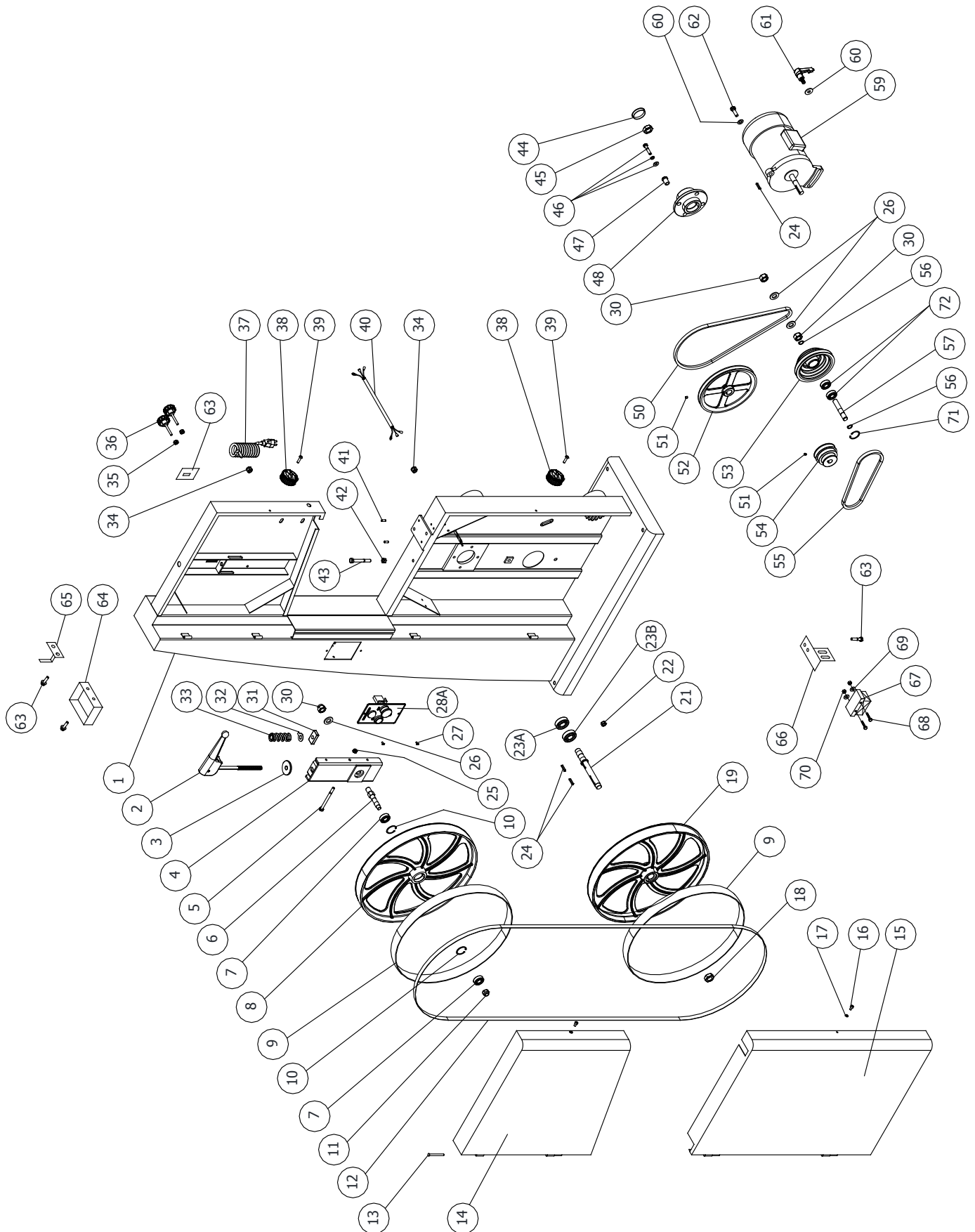



# CX108N PARTS LIST

KEY	PART #	DESCRIPTION	KEY	PART #	DESCRIPTION
1	PCX108N01	BODY	37	PCX108N37	POWER CORD
2	PCX108N02	QUICK HANDLE BAR	38	PCX108N38	GUARD LOCKING KNOB
3	PCX108N03	WASHER - T TYPE	39	PCX108N39	SPECIAL HIGH CAP SCREW 7x19-1/4"
4	PCX108N04	UPPER WHEEL BRACKET	40	PCX108N40	CORD
5	PCX108N05	HEX BOLT-M8*110mm	41	PCX108N41	PIN 6*16mm
6	PCX108N06	UPPER WHEEL SHAFT 17MM	42	PCX108N42	HEX NUT 3/8"-16P
7	PCX108N07	BEARING	43	PCX108N43	HEX BOLT 3/8-16P84"
8	PCX108N08	UPPER WHEEL	44	PCX108N44	BEARING COVER
9	PCX108N09	WHEEL TIRE	45	PCX108N45	NUT
10	PCX108N10	INTERNAL RETAINING RING R40	46	PCX108N46	HE BOLT 5/16-18P*1-1/2"
11	PCX108N11	RETAINER NUT 1/2"-P12	47	PCX108N47	ADJUSTING SCREW
12	PCX108N12	BLADE 133" LONG	48	PCX108N48	BEARING BASE
13	PCX108N13	HINGE PIN	50	PCX108N50	V-BELT A41
14	PCX108N14	UPPER DOOR	51	PCX108N51	SCREW - SET 1/4-20P*1/4"
15	PCX108N15	LOWER DOOR	52	PCX108N52	PULLEY
16	PCX108N16	CAP SCREW 1/4"-20P*3/8	53	PCX108N53	PULLEY
17	PCX108N17	LOCK WASHER 1/4"	54	PCX108N54	MOTOR PULLEY
18	PCX108N18	HEX NUT 3/4"-16P(L.H)	55	PCX108N55	V-BELT A25
19	PCX108N19	LOWER WHEEL	56	PCX108N56	EXTERNAL RETAINING RING S15
21	PCX108N21	LOWER WHEEL SHAFT	57	PCX108N57	SHAFT
22	PCX108N22	LOCK NUT 3/8"-16P	59	PCX108N59	MOTOR
23A	PCX108N23A	BEARING	60	PCX108N60	FLAT WASHER 3/8"
23B	PCX108N23B	BEARING 6005ZZ	61	PCX108N61	LOCK KNOB
24	PCX108N24	KEY 5*5*40mm	62	PCX108N62	HEX BOLT 3/8-16P*2-1/2"
25	PCX108N25	NYLON NUT M8-P1.25	63	PCX108N63	HEX BOLT 1/4-20P*3/4"
26	PCX108N26	FLAT WASHER 5/8"	64	PCX108N64	TOOL TRAY
27	PCX108N27	PHILLIPS FLAT HEAD SCREW 3/16*1/2	65	PCX108N65	HOLDER
28A	PCX108N28A	CONTROL SWITCH ASSY	66	PCX108N66	BRUSH BASE
30	PCX108N30	HEX NUT 5/8"	67	PCX108N67	BRUSH
31	PCX108N31	NUT	68	PCX108N68	PHILLIPS FLAT HEAD SCREW 3/16*1-1/2"
32	PCX108N32	BLADE TENSION POINTER	69	PCX108N69	FLAT WASHER 3/16-12
33	PCX108N33	SPRING	70	PCX108N70	HEX NUT 3/16"
34	PCX108N34	STRAIN RELIEF	71	PCX108N71	INTERNAL RETAINING RING R35
35	PCX108N35	HEX NUT 5/16"-18P	72	PCX108N72	BEARING 6202VV
36	PCX108N36	KNOB 5/16-18x2"			

# CX108N PARTS DIAGRAM

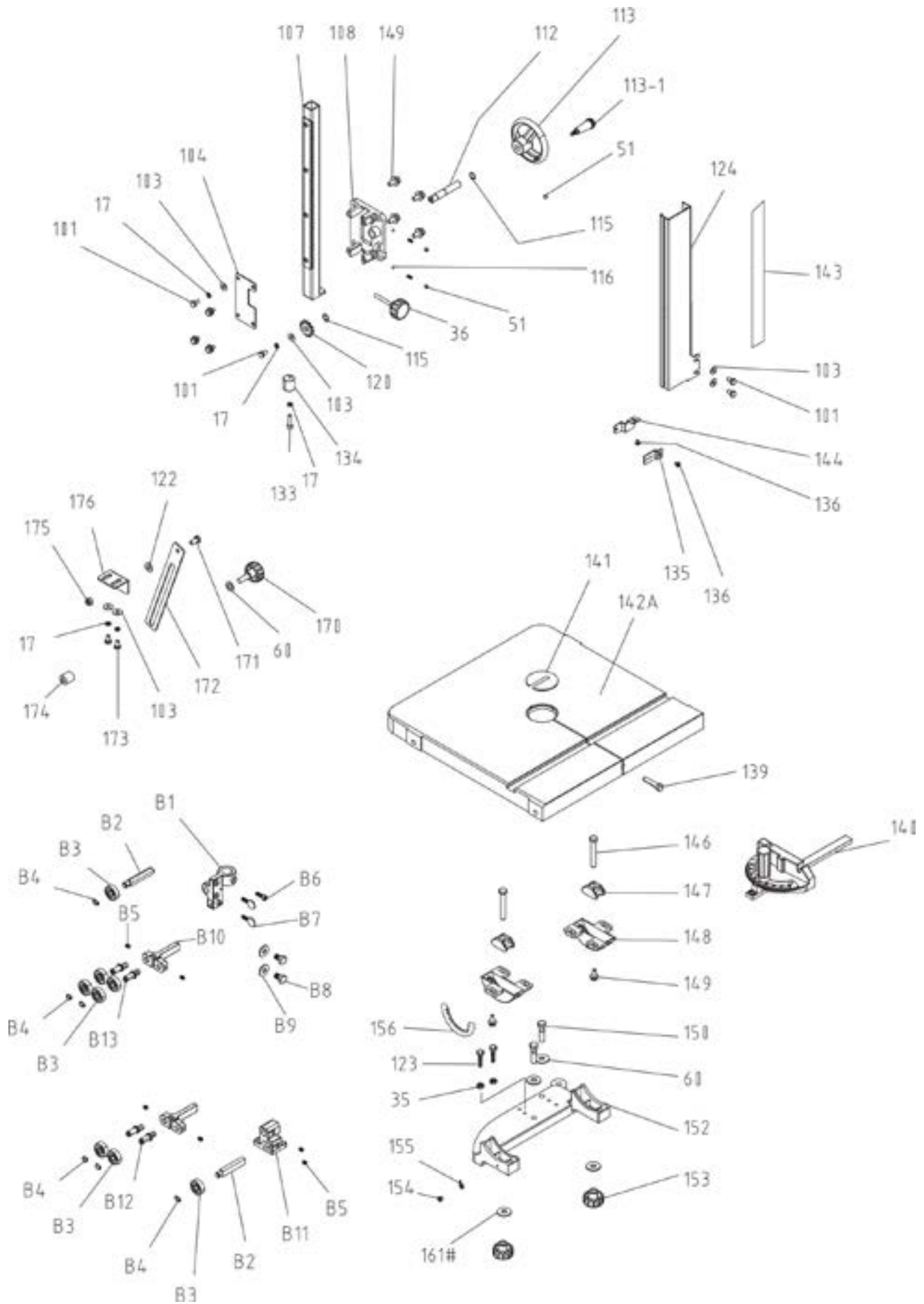

# CX108N TABLE PARTS LIST

KEY	PART #	DESCRIPTION	KEY	PART #	DESCRIPTION
101	PCX108N101	BOLT - HEX HD - 1/4-20P*3/8"	150	PCX108N150	HEX BOLT 3/8*2"
103	PCX108N102	WASHER - FLAT 1/4-16*1.2mm	152	PCX108N152	TRUNNION SUPPORT BRACKET
104	PCX108N104	GUIDE BAR COVER	153	PCX108N153	KNOB
107	PCX108N107	GUIDE BAR	154	PCX108N154	PHILLIPS HEAD SCREW 3/16"-24P*1/4"
108	PCX108N108	BRACKET	155	PCX108N155	POINTER
112	PCX108N112	PINION SHAFT	156	PCX108N156	GAUGE LABEL
113	PCX108N113	HANDLE WHEEL	161	PCX108N161	FLAT WASHER 3/8"-19
113-1	PCX108N113-1	HANDLE	170	PCX108N170	KNOB BOLT 3/8"*1 1/4"
115	PCX108N115	EXTERNAL RETAINING RING S13	171	PCX108N171	HEX BOLT 5/16-18P*1"
116	PCX108N116	BALL	172	PCX108N172	ANGLE ADJUSTMENT PLANE
120	PCX108N120	PINION GEAR	173	PCX108N173	HEX BOLT 1/4-20*1/2"
122	PCX108N122	FLAT WASHER 5/16" - 20	174	PCX108N174	BUSHING
123	PCX108N123	HEX BOLT 5/16*2"	175	PCX108N175	NYLON NUT 5/16"
124	PCX108N124	BLADE COVER	176	PCX108N176	ADJUSTMENT BAR BRACKET
133	PCX108N133	CAP SCREW 1/4*7/8"-20P	B1	PCX101N1B1	SUPPOER BRACKET CAST IRON 7/8" ID
134	PCX108N134	GUIDE POST	B2	PCX101N1B2	SUPPORT BEARING SHAFT
135	PCX108N135	POINTER	B3	PCX101N1B3	BEARING 6200ZZ
136	PCX108N136	PHILLIPS HEAD SCREW 3/16"-24P*1/4"	B4	PCX101N1B4	EXTERNAL RETAINING RING S10
139	PCX108N139	TABLE PIN	B5	PCX101N1B5	SET SCREW 1/4-20P*1/4"
140	PCX108N140	MITER GAUGE ASSY	B6	PCX101N1B6	HEX BOLT 1/4-20*1/2"
141	PCX108N141	TABLE INSERT ALUMINUM	B7	PCX101N1B7	THUMBSCREW 1/4*3/4"20P
142A	PCX108N142A	TABLE	B8	PCX101N1B8	HEX BOLT 1/4-20P*3/8"
143	PCX108N143	SCALE	B9	PCX101N1B9	FLAT WASHER 1/4"-25
144	PCX108N144	POINTER PLATE	B10	PCX101N1B10	SUPPORT
146	PCX108N146	HEX BOLT 3/8-16P*2-1/2"	B11	PCX101N1B11	LOWER SUPPORT BRACKET
147	PCX108N147	TRUNNION CLAMPSHOE	B12	PCX101N1B12	BEARING SHAFT (BEARING SUPPORT)
148	PCX108N148	TRUNNION	B13	PCX101N1B13	GUIDE SHAFT (L)
149	PCX108N149	HEX BOLT 5/16-18P*3/4"			

# CX108N FENCE PART LIST

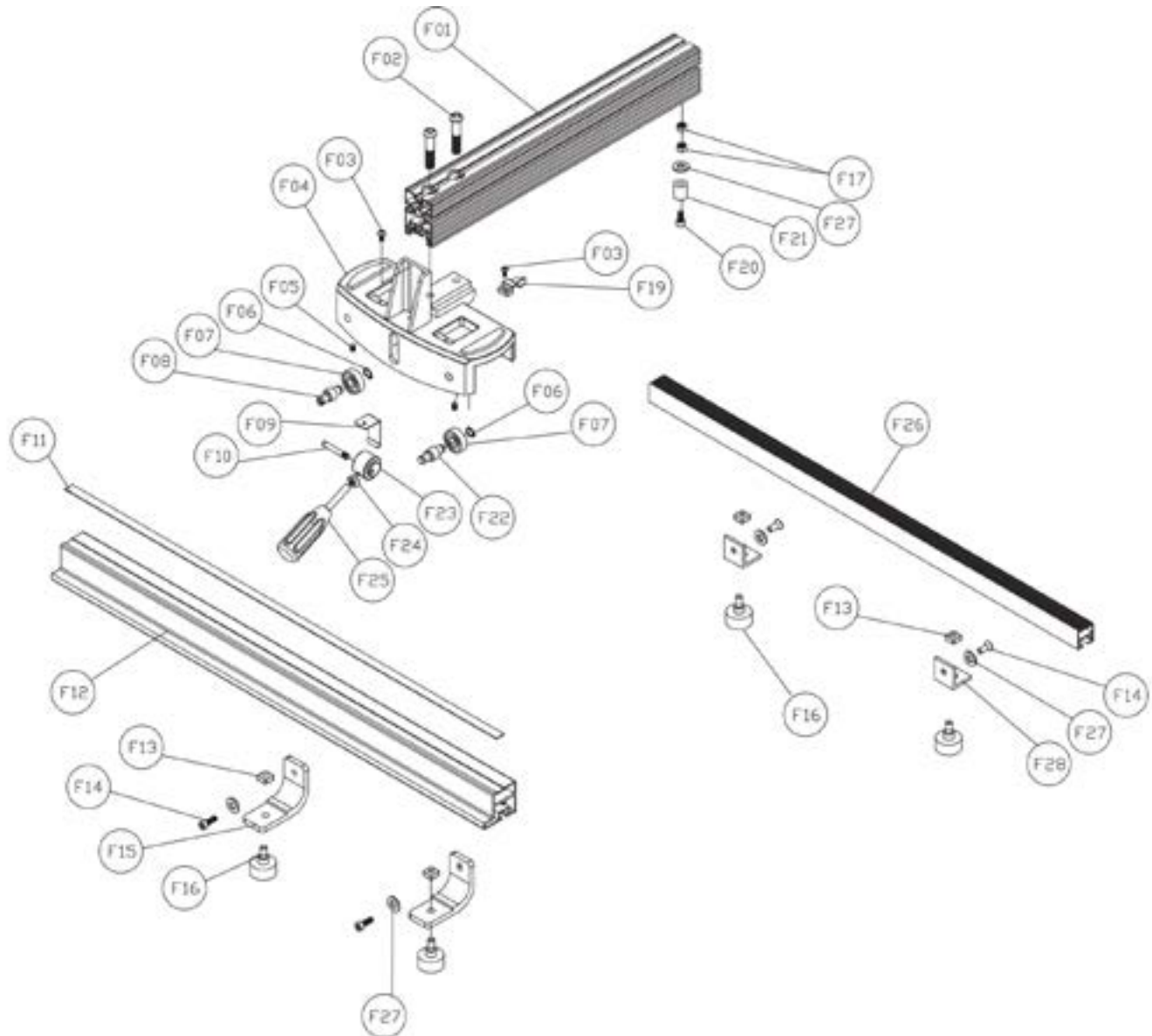

KEY	PART #	DESCRIPTION	KEY	PART #	DESCRIPTION
F01	PCX108NF01	FENCE BODY	F15	PCX108NF15	L TYPE PLATE
F02	PCX108NF02	FLAT HEAD CAP SCREW M10*25mm	F16	PCX108NF16	KNOB 5/16-18 X 5/8
F03	PCX108NF03	FLAT HEAD CAP SCREW M5*10mm	F17	PCX108NF17	HEX NUT M6
F04	PCX108NF04	FENCE BASE	F18	PCX108NF18	FENCE RAIL REAR
F05	PCX108NF05	SCREW - SET 1/4-20P*1/4"	F19	PCX108NF19	POINTER
F06	PCX108NF06	EXTERNAL RETAINING RING S10	F20	PCX108NF20	SOCKET HEAD CAP SCREW M6*16mm
F07	PCX108NF07	BEARING 6200ZZ	F21	PCX108NF21	RUNNER
F08	PCX108NF08	ECENTRIC SHAFT	F22	PCX108NF22	BEARING SHAFT
F09	PCX108NF09	PRESSURE PLATE	F23	PCX108NF23	LOCK MECHANISM
F10	PCX108NF10	PIN	F24	PCX108NF24	HEX NUT 8mm-1.25p
F11	PCX108NF11	FENCE SCALE	F25	PCX108NF25	FENCE HANDLE
F12	PCX108NF12	FRONT FENCE RAIL	F26	PCX108NF26	REAR RAIL
F13	PCX108NF13	SQYARE NUT 5/16"	F27	PCX108NF27	FLAT WASHER 1/4- 16*1.2mm
F14	PCX108NF14	HEX BOLT 1/4" X 5/8"	F28	PCX108NF28	L BRACKET



## WARRANTY

### CRAFTEX MACHINERY WARRANTY

Busy Bee Tools warrants every Craftex machine to be free from defects in materials and agrees to correct such defects where applicable. This warranty covers two years for Craftex CT-Series machines and three years for Craftex CX-Series Machines and 90 days for labour (unless specified otherwise), to the original purchaser from the date of purchase but does not apply to malfunctions arising directly or indirectly from misuse, abuse, improper installation or assembly, negligence, accidents, repairs or alterations or lack of maintenance. *Proof of purchase is necessary.*

All warranty claims are subject to inspection of such products or part thereof and Busy Bee Tools reserves the right to inspect any and all items before a refund or replacement may be issued. A Machinery Return Form must be filled out by the original purchaser requesting a return. Authorization may take up to 72 hours for inspection and approval.

This warranty shall not apply to consumable products such as blades, bits, belts, cutters, chisels, punches etc...

Busy Bee Tools shall in no event be liable for injuries, accidental or otherwise, death to persons or damage to property or for incidental contingent, special or consequential damages arising from the use of our products.

#### RETURNS, REPAIRS AND REPLACEMENTS

To return, repair, or replace a Craftex Machine, a Machinery Return Form must be filled out by the original purchaser requesting a return. Visit the appropriate Busy Bee Tools showroom or call 1-800-461-BUSY. Craftex is a brand of equipment that is exclusive to Busy Bee Tools.

For replacement parts directly from Busy Bee Tools, for this machine, please call 1-800-461-BUSY (2879), and have your credit card and part number handy. You can find the part number in the back of your owner's manual under the parts list & exploded diagram.

- All returned merchandise will be subject to a minimum charge of 15% for re-stocking and handling.
- A Machinery Return Form must be filled out by the original purchaser requesting a return and it must be approved by Busy Bee Tools in writing before accepting a return.
- We do not accept *collect* shipments.
- Items returned for warranty purposes must shipped pre-paid to the nearest warehouse.
- Returns must be accompanied with a copy of your original invoice as proof of purchase. Incurred shipping and handling charges are not refundable.
- Busy Bee Tools will repair or replace the item at our discretion and subject to our inspection.
- Busy Bee Tools reserves the right to refuse reimbursement or repairs or replacement if a third party without our prior authorization has carried out repairs to the item.
- Repairs made by Busy Bee Tools are warranted for 30 days on parts and labour.
- Any unforeseen repair charges will be reported to you for acceptance prior to making the repairs.
- Replacement motors purchased from Busy Bee Tools carry a 90 manufactures defect warranty.
- The Busy Bee Tools Parts & Service Departments are fully equipped to do repairs on all Craftex products purchased from us with the exception of some products that require the return to their authorized repair depots. A Busy Bee Tools representative will provide you with the necessary information to have this done.

Effective Date: 05/18/21

