



CX109
4-1/2" METAL CUTTING BAND SAW
WITH SWIVEL HEAD
User Manual



 **COPYRIGHT © 2012 BY CRAFTEX INDUSTRIES INC.** NO PORTION OF THIS MANUAL MAY BE PRODUCED WITHOUT THE WRITTEN CONSENT OF CRAFTEX INDUSTRIES INC. 

Table of Contents

General Safety Instructions	3
Specific Safety Instructions.....	4
Features	5
Physical Features	6
Proper Grounding.....	7
Unpacking	8
Setup	8
Cleaning	8
Assembly	9
Vertical Cutting Table	10
Stop Bolt.....	11
Test Run.....	12
Speed Changes.....	12
Vise	13
Swivel Head.....	13
Squaring Blade to the Base	13
Blade Selection.....	14
Blade Direction of Travel	14
Blade Tension.....	14
Blade Changing	14
Maintenance	15
Machine Storage	15
Troubleshooting.....	16
Parts Breakdown	18
Parts List	20
Warranty	21

GENERAL SAFETY INSTRUCTIONS

Extreme caution should be used when operating all power tools. Know your power tool, be familiar with its operation, read through the owner's manual and practice safe usage procedures at all times.

- ❖ **ALWAYS** read and understand the user manual before operating the machine.
- ❖ **CONNECT** your machine **ONLY** to the matched and specific power source.
- ❖ **ALWAYS** wear safety glasses respirators, hearing protection and safety shoes, when operating your machine.
- ❖ **DO NOT** wear loose clothing or jewelry when operating your machine.
- ❖ **A SAFE ENVIRONMENT** is important. Keep the area free of dust, dirt and other debris in the immediate vicinity of your machine.
- ❖ **BE ALERT! DO NOT** use prescription or other drugs that may affect your ability or judgment to safely use your machine.
- ❖ **DISCONNECT** the power source when changing drill bits, hollow chisels, router bits, shaper heads, blades, knives or making other adjustments or repairs.
- ❖ **NEVER** leave a tool unattended while it is in operation.
- ❖ **NEVER** reach over the table when the tool is in operation.
- ❖ **ALWAYS** keep blades, knives and bits sharpened and properly aligned.
- ❖ **ALL OPERATIONS MUST BE** performed with the guards in place to ensure safety.
- ❖ **ALWAYS** use push sticks and feather boards to safely feed your work through the machine.
- ❖ **ALWAYS** make sure that any tools used for adjustments are removed before operating the machine.
- ❖ **ALWAYS** keep the bystanders safely away while the machine is in operation.

4-1/2" METAL CUTTING BAND SAW SAFETY INSTRUCTIONS

- ⊠ **CX109** is designed to cut metal only.
- ⊠ **ALWAYS** inspect the blade for any crack or missing teeth before operating the band saw.
- ⊠ **ALWAYS** ensure that the blade tension is properly set for the type and width of blade installed.
- ⊠ **NEVER** place your fingers or hands in the line of cut. If you slip, your hands or fingers may come into contact with the blade.
- ⊠ **ALL THE GUARDS** must be in place while operating the band saw to ensure safety.
- ⊠ **ALWAYS** feed the stock smoothly. Do not force or twist the work-piece while cutting.
- ⊠ **MAKE SURE** before making any adjustments, the switch is in the "OFF" position and the cord is un-plugged from the power source.
- ⊠ **NEVER LEAVE** the band saw unattended while it is running. Turn the switch to the OFF position and unplug the cord before you leave.
- ⊠ **DO NOT** attempt to remove jammed pieces unless the band saw blade has come to a complete stop and the power switch has been turned to the **OFF** position.
- ⊠ **NEVER** the band saw ON if the blade is in contact with your stock.
- ⊠ **ALWAYS** make certain that the bearings are properly adjusted to guide the blade.
- ⊠ **MAINTAIN AND SERVICE** your band saw regularly as instructed in the user manual.
- ⊠ **MAKE SURE** you have read and understood all the safety instructions in the manual and you are familiar with your band saw, before operating the CX109. If you fail to do so, serious injury could occur.

WARNING!

The safety instructions given above can not be complete because the environment in every shop is different. Always consider safety first as it applies to your individual working conditions.



4-1/2" METAL CUTTING BAND SAW FEATURES

MODEL CX109 – 4-1/2" METAL CUTTING BAND SAW WITH SWIVEL HEAD

As part of the growing line of Craftex metalworking equipment, we are proud to offer CX109 a 4-1/2" Metal Cutting Band Saw with Swivel Head. By following the instructions and procedures laid out in this owner's manual, you will receive years of excellent service and satisfaction. The CX109 is a professional tool and like all power tools, proper care and safety procedures should be adhered to.

- ❖ Motor 1/3 HP, 110V, Single Phase
- ❖ Capacity @ 90° 4" x 6" Rectangular, 4" Round
- ❖ Capacity @ 45° 4" x 3" Rectangular, 3-1/2" Round
- ❖ Table 8" x 8-3/4"
- ❖ Blade Speed 80, 120 & 220 FPM
- ❖ Blade Size 1/2" x .025" x 64-1/2"
- ❖ Gear Box Sealed Worm Gear
- ❖ Ball Bearing Drive Wheels and Blade Guides.....Yes
- ❖ Auto Shut Off Yes
- ❖ Heavy Duty Cast Iron Base . Yes
- ❖ Powdered Coated Paint..... Yes
- ❖ Carton Size..... 17" x 18" x 40"
- ❖ Approximate Weight 68 Kg
- ❖ Warranty 3 Years

4-1/2" METAL CUTTING BAND SAW PHYSICAL FEATURES

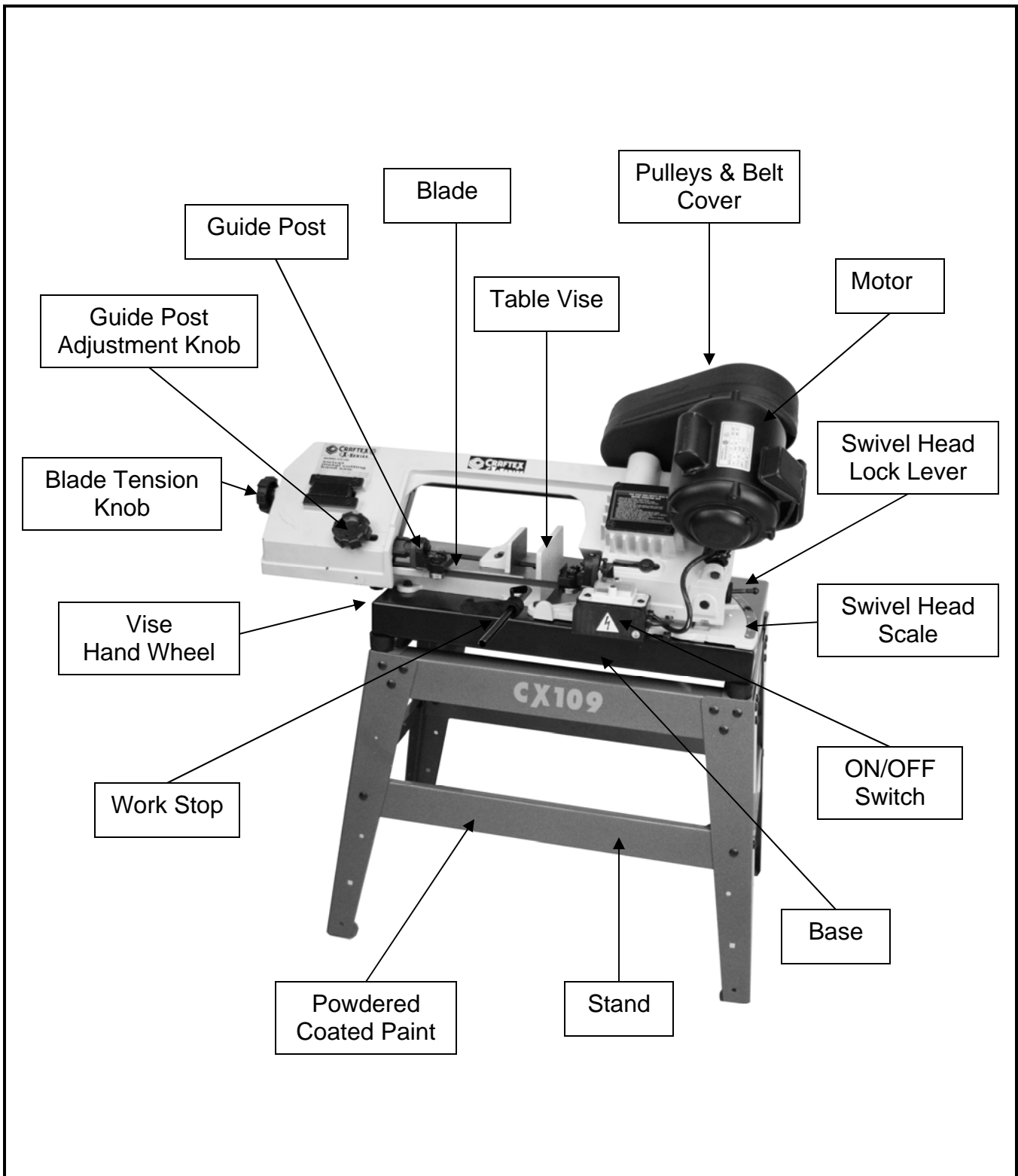

PROPER GROUNDING

Grounding provides a path of least resistance for electric current to reduce the risk of electric shock.

To prevent electrical hazards, have a qualified electrician ensure that the line is properly wired.

This machine is for use on a normal 110 volts circuit. Make sure that the machine is connected to an outlet having the same configuration as the plug. If an adaptor plug is used, it must be attached to the metal screw of the receptacle.

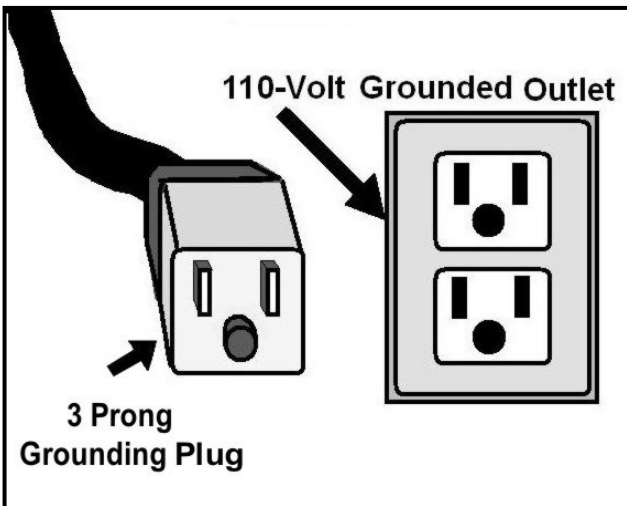

Figure-1 110-Volts Outlet for CX109

WARNING!

Improper connection of the equipment-grounding conductor can result in a risk of electric shock. Check with a qualified electrician if you are in doubt as to whether the outlet is properly grounded.

It is strongly recommended not to use extension cords with your CX109. Always try to position your machine close to the power source so that you do not need to use extension cords.

If it necessary to use an extension cord, make sure the extension cord does not exceed 50-feet in length and the cord is 14-gauge to prevent motor damage. Check for heat build up periodically.

Your CX109 should be wired with a 3-prongs plug fitting a 3 prong grounded receptacles as shown in figure-1. Do not remove the grounding prong to fit it into a 2-pronged outlet. Always check with a qualified electrician if you are in doubt.

UNPACKING

The machine is properly packaged and shipped completely in a box for safe transportation. When unpacking, carefully inspect the box and ensure that nothing has been damaged during transit. Open the box and check that the machine and the parts are in good condition.

NOTICE

While doing inventory, if you can not find any part, check if the part has already been installed on the machine. Some parts come pre-assembled for shipping purposes.

SETUP

Before setting up your machine you should read and understand the instructions given in this manual.

To prevent any damage to the machine during shipping, the band saw comes with it is head secured to the base with a bracket. Remove the two screws using a screw driver and remove the bracket securing the saw head to the base. See figure-2.

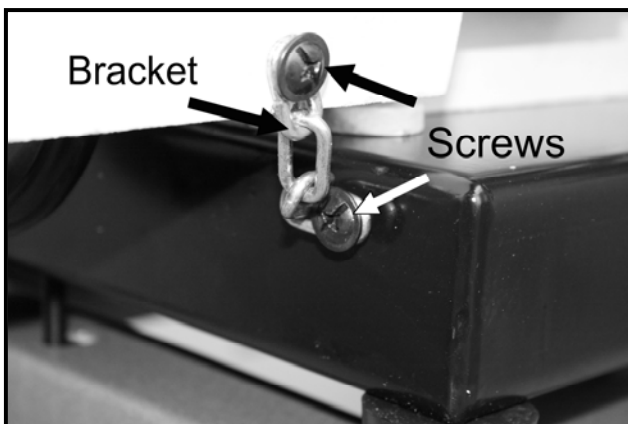

Figure-2 Removing the bracket

WARNING!

CX109 is a very heavy machine, do not over-exert yourself. For safe moving method use fork truck. Failure to do so could result in serious personal injury and damage to the machine.

When setting up your machine, you will want to find an ideal spot where your band saw will most likely be positioned most of the time. Consider your complete work environment before placing your machine in the ideal spot.

CLEANING

The unpainted surfaces of this band saw are coated with a rust preventive waxy oil and you will want to remove this before you begin assembly. Use a solvent cleaner that will not damage painted surfaces.

ASSEMBLY

To assemble the CX109 metal working band saw, follow the instructions given below:

Attach the upper short brackets to two stand legs and secure it using carriage bolts, washers and nuts provided. See figure-3.

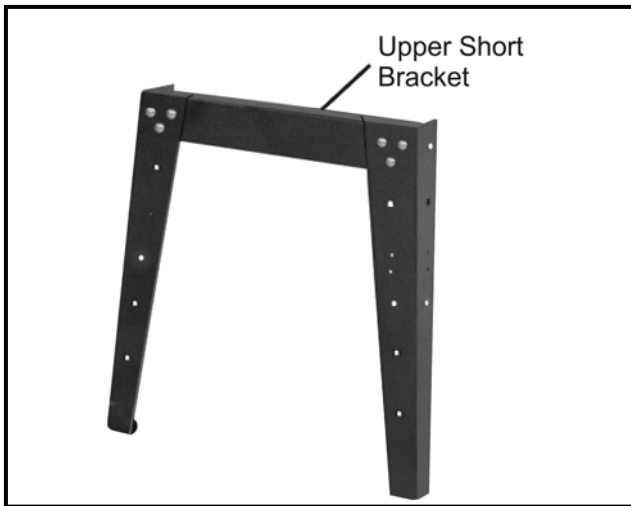

Figure-3 Attaching upper short brace to the legs

Attach the lower short bracket to the leg assembly and secure it using carriage bolts, washers and nuts provided. See figure-4.



Figure-4 Installing the lower short brace to the leg assembly

Assemble the other two legs with the short brackets in the same manner.

Attach the leg assemblies with the two lower and two upper long brackets using carriage bolts, washers and nuts provided. See figure-5.

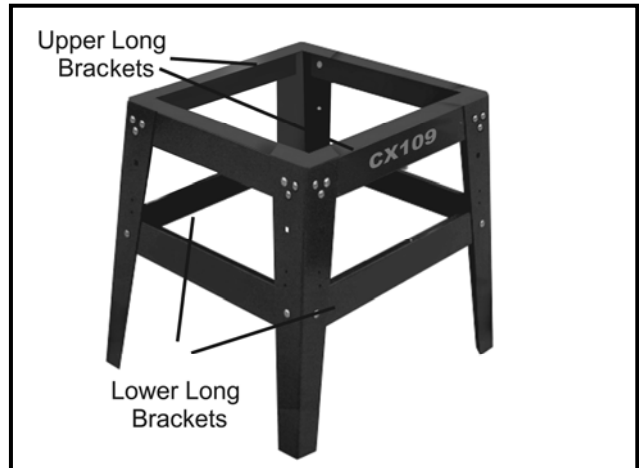

Figure-5 Stand assembly

Get the help of an assistant and lift the band saw up, onto the stand making sure that the rubber feet on the band saw base are sitting on the four corners of the stand and the model number "CX109" is facing the same direction as the front of the band saw. See figure-6.



Figure-6 Installing the band saw onto the stand

Align the holes on the band saw base with the holes on the stand. Secure the band saw onto the stand from under the base using two long bolts, washers and nuts (provided) as shown in figure-7.

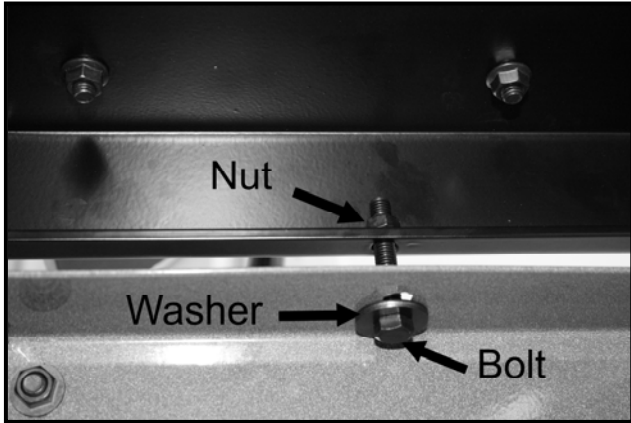

Figure-7 Securing the band saw onto the stand

Insert the work stop rod through the hole in the bed of the saw and lock it in position by tightening the set screw shown in figure-8. Now, take the work stop and slide it over the rod and secure it by tightening the thumb screw shown in figure-8.

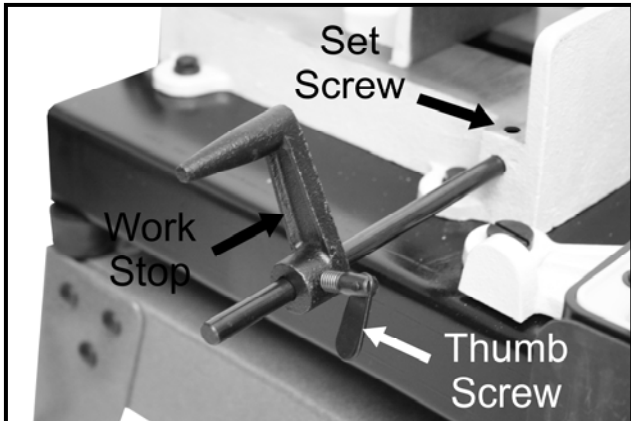

Figure-8 Installing the work stop

Take the belt cover and slide in over the pulleys as shown in figure-9 and secure it by tightening two screws.



Figure-9 Installing the motor cover

VERTICAL CUTTING WORK TABLE

CX109 can easily be set up for vertical use. Notching, Slitting and contour work maybe be done with CX109 in the vertical position.

Vertical cutting work table is used on the band saw only in vertical cutting mode. When using the saw in horizontal position, make sure the cutting table is removed.

To install the vertical cutting table:

1. Make sure the power cord is disconnected from power source.
2. Remove the bolt shown in figure-10 so that the band saw can be positioned at 90°.

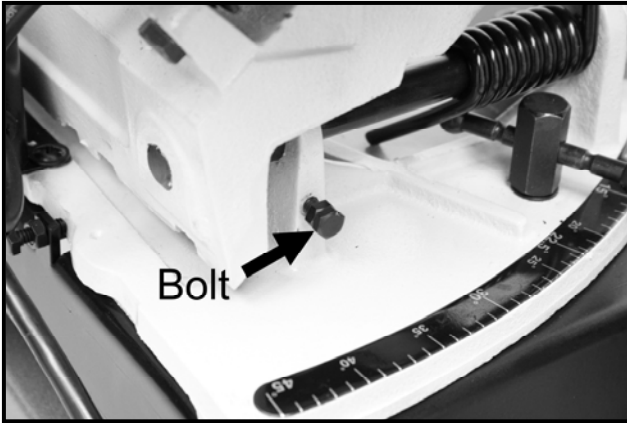

Figure-10 Removing the bolt to position the band saw at 90°

3. Once the bolt is removed, lift the saw arm to the vertical position.
4. Use a screw driver and remove the two screws as shown in figure-11.



Figure-11 Removing the two screws

5. Guide the blade through slot in the table and secure the table with two screws removed in step-4. See figure-12.

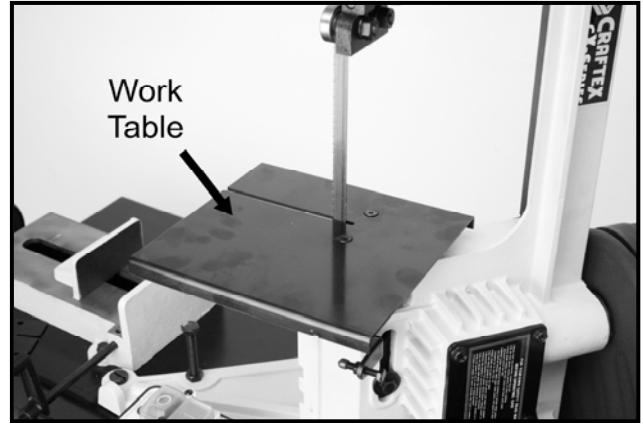

Figure-12 Installing the work table

STOP BOLT

Stop bolt is located on the band saw base and is adjusted to stop the band saw at the desired height when cutting.

To adjust the stop bolt:

Loosen the lock nut shown in figure-13 and thread the bolt in or out. Once the bolt is at the desired height, re-tighten the lock nut.

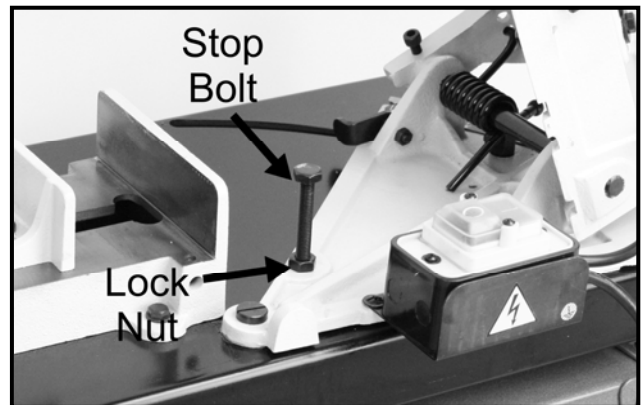

Figure-13 Stop bolt

TEST RUN

Now that you have assembled your machine completely, it is time for a test run to make sure that the machine works properly and is ready for operation.

All the tools and objects used for assembling the machine should be removed and cleared away during the test run.

WARNING!

Before starting the dust collector, make sure that you have read and understood the manual and you are familiar with the functions and safety features on this machine. Failure to do so may cause serious personal injury.

Plug the cord to the power outlet and turn the dust collector ON. See if the dust collector operates correctly.

During the test run if there is any unusual noise coming from the machine or the machine vibrates excessively, shut off the machine immediately and disconnect the cord from the power source. Check all the parts you have assembled once again and investigate to find out the problem.

SPEED CHANGES

The CX109 features 3 speeds and the speeds changes can be performed by positioning the belt on different grooves on the motor pulley and saw pulley.

To change the speed:

Make sure the switch is in the OFF position the cord is disconnected from the power source.

Open the pulley cover to access the pulleys. Loosen the screw on the motor bracket shown in figure-14. This will loosen the tension on the belt.



Figure-14 Loosening the tension on the belt

Once the belt tension is released, position the belt on to the pulleys grooves to obtain the desired speed. See figure-15.

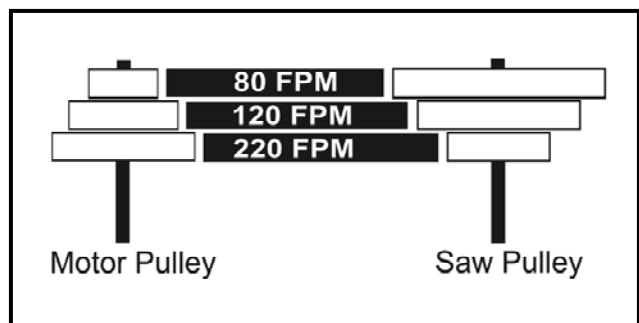

Figure-15 Belt position on the pulleys for speed changes

WISE

The CX109 features a heavy duty vise to hold the work-piece for safe and accurate cutting.

To use the vise:

Lift the saw arm and place the work-piece between the jaws of the vise. Secure the work-piece between the jaws by turning the vise hand wheel. See figure-16.

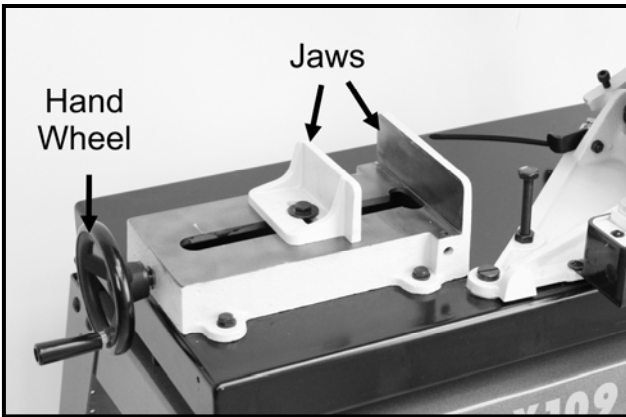

Figure-16 Vise jaws and hand wheel

SWIVEL HEAD

The CX109 features swivel head which allows cutting work-pieces in different angles up to 45°.

To rotate the head:

Make sure the switch is in the OFF position the cord is disconnected from the power source.

Loosen the lock lever shown in figure-17 and rotate the head to the desired angle using the angle indicator. Re-tighten the lock lever when the head is in the desired angle.

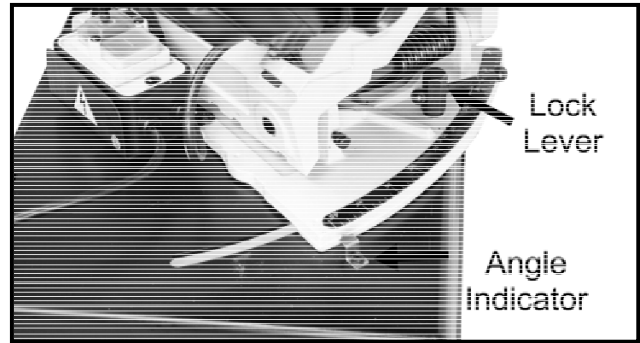

Figure-17 Rotating the head

SQUARING BLADE TO THE BASE

1. Turn the switch OFF and disconnect the cord from the power source.
2. Take a machinist's square and place it on the base as shown in figure-18.

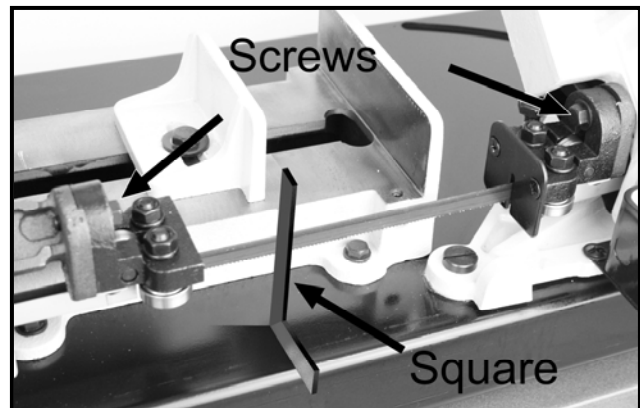

Figure-18 Squaring the blade to the base

3. Check to see if the blade is making contact along the entire width of the blade.
4. If adjustment is necessary, loosen screw shown in figure-18 and rotate the blade guide slightly until the blade is square along its entire width with the base and re-tighten the screws.

BLADE SELECTION

An 8-tooth per inch, general use blade is furnished with this metal cutting band saw. Additional blades in 4, 6, 8 and 10 teeth sizes are available. The choice of the blade pitch is governed by the thickness of the work-piece to be cut. The thinner the work-piece, the blade with more teeth should be used. A minimum of three teeth should engage the work-piece at all times for proper cutting. If the teeth of the blade are so far apart that they straddle the work, severe damage can occur to the work-piece and to the blade.

BLADE DIRECTION OF TRAVEL

The blade is mounted on the wheels such that the vertical edge engages the work-piece first. See figure-19.

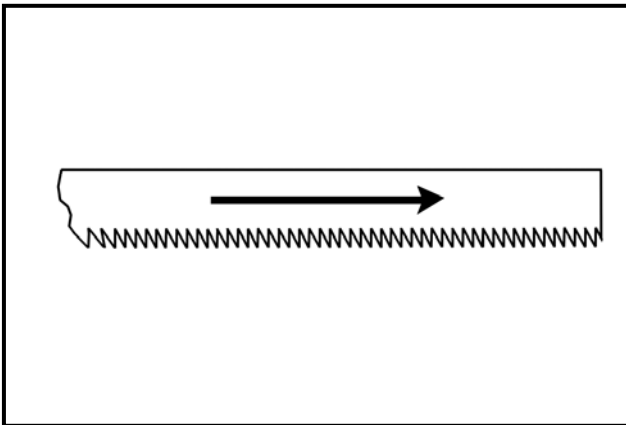

Figure-19 Shows blade direction of travel

BLADE TENSION

A properly tensioned blade is very important to get the best performance from any band saw. If the blade is too loose there is a possibility that the blade slip or

drift off the line while operation and it will be hard to have accuracy in the line of cut. If the blade is tensioned too tightly, it will be very difficult to make tighter radius cuts and secondly there will be a great possibility of breaking prematurely.

To adjust the blade tension:

Turn the switch OFF and disconnect the cord from the power source.

Turn the blade tension knob shown in figure-20 clockwise to increase the tension on the blade and turn it counter clockwise to decrease the blade tension.

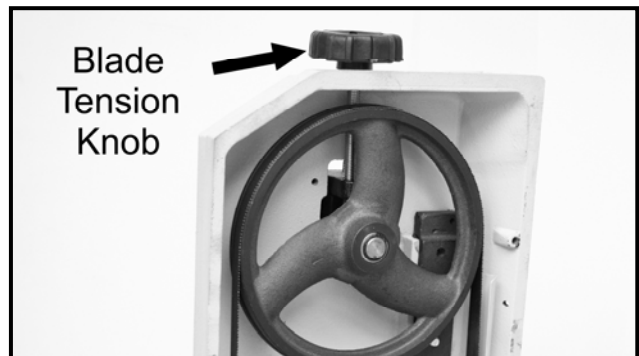

Figure-20 Blade tensioning

IMPORTANT

To prolong the life of the blade and reduce blade stretching, when the machine is not in use for period of 24 hours or more, release the tension on the blade

BLADE CHANGING

The band saw blade is sharp and while changing the blade you should wear leather gloves for the protection of your hands.

Lift the saw to the vertical position and remove the back cover by removing the three screws shown in figure-21.

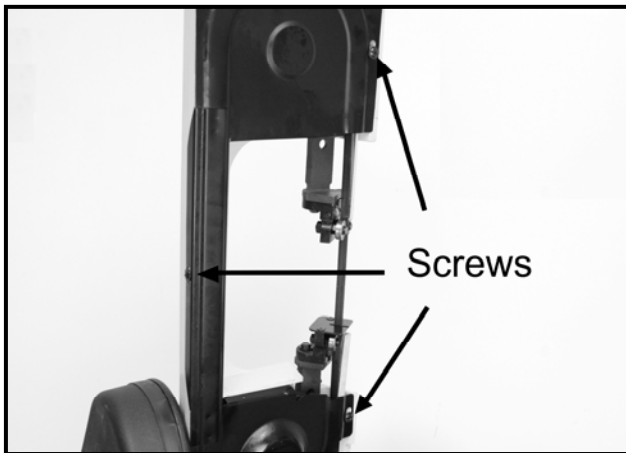

Figure-21 Removing the back cover

Loosen the blade tension knob allowing the saw blade to slip off the wheels.

Carefully remove the blade and place the new blade in between each of the guide bearings.

With teeth towards the motor position the blade around the motor wheel and hold it in place with left hand.

Hold the blade tight against the motor wheel by pulling the blade upward with the right hand which is placed at the top of the blade.

Remove your left hand from the bottom wheel and place it at the top side of the blade to continue the application on the upper wheel on the blade.

Remove your right hand from blade and adjust the position of the top wheel to permit left hand to slip the blade around the wheel.

Adjust the blade tension knob clockwise until it is just right enough so that no blade slippage occurs.

Install the back cover.

Apply a few drops of oil on the blade.

Square the blade to the base. See page-13 for details.

MAINTENANCE

During the life of your machine, you will need to practice some regular maintenance to keep your saw in peak performance condition.

WARNING!

Make sure the machine is turned off and the cord is disconnected from the power source before servicing and removing/replacing any components on the machine.

Check the band saw daily for loose mounting bolts/screws, damaged wires, worn switch and any other unsafe condition.

MACHINE STORAGE

When the band saw is not in use, disconnect the cord from the power source and store the machine in a dry place. Do not expose the machine to rain. Make sure to keep the cord away from potential damage sources such as; sharp objects, chemicals, heat sources and water.

TROUBLE SHOOTING

SYMPTOM	POSSIBLE CAUSE	CORRECTIVE ACTION
Excessive Blade Breakage	<ol style="list-style-type: none"> 1. Incorrect blade tension 2. Incorrect speed or feed 3. Material loose in vise 4. Blade rubs on wheel flange 5. Teeth too coarse for material 6. Teeth in contact with work before saw is started 7. Misaligned guides 8. Blade too thick for wheel diameter 9. Cracking at weld 	<ol style="list-style-type: none"> 1. Adjust to where blade just does not slip on wheel 2. Check machinist handbook 3. Clamp work securely 4. Adjust wheel alignment 5. Check machinist handbook for recommended blade type 6. Place blade in contact work after motor is started 7. Adjust 8. Use thinner blade 9. Make longer annealing cycle
Premature Blade Dulling	<ol style="list-style-type: none"> 1. Teeth too coarse 2. Too much speed 3. Inadequate feed pressure 4. Hard spots or scale in/on material 5. Work hardening of material (specially stainless steel) 6. Blade installed backwards 7. Insufficient blade tension 	<ol style="list-style-type: none"> 1. Use finer teeth blade 2. Try next lower speed 3. Decrease spring tension on side of saw 4. Reduce speed increase feed pressure (scale) Increase feed pressure (hard spots) 5. Increase feed pressure by reducing spring tension 6. Remove blade twist inside out and reinstall 7. Increase tension to proper level
Blade Cuts (Crooked)	<ol style="list-style-type: none"> 1. Work no square 2. Feed pressure too great 3. Guide bearing not adjusted properly 4. Inadequate blade tension 5. Blade guides spaced out too much 6. Dull blade 7. Speed Incorrect 8. Blade guide assembly loose 9. Blade guide bearing assembly loose 10. Blade tracks too far away from wheel flanges. 	<ol style="list-style-type: none"> 1. Adjust the vise to be square with the blade and always clamp the work-piece 2. Reduce pressure by increasing spring tension on side of the saw. 3. Adjust guide bearing to .001 greater than maximum thickness, including weld of the saw. 4. Increase blade tension a little at a time 5. Move guide to the work-piece as close as possible 6. Replace blade 7. Check manual for recommended speeds 8. Tighten 9. Tighten 10. Redo the blade tracking adjustment according to the manual

TROUBLE SHOOTING

SYMPTOM	POSSIBLE CAUSE	CORRECTIVE ACTION
Blade Cuts (Rough)	<ol style="list-style-type: none"> 1. Too much speed or feed 2. Blade is too coarse 	<ol style="list-style-type: none"> 1. Reduce speed and feed 2. Replace with finer blade
Blade is Twisting	<ol style="list-style-type: none"> 1. Cut is binding blade 2. Too much blade tension 	<ol style="list-style-type: none"> 1. Decrease feed pressure 2. Decrease blade tension
Un-usual Wear on Side/Back of Blade	<ol style="list-style-type: none"> 1. Blade guides worn 2. Blade guides bearings not adjusted properly 3. Blade guide bearing bracket is loose 	<ol style="list-style-type: none"> 1. Replace 2. Adjust as per operators manual 3. Tighten
Teeth Ripping from Blade	<ol style="list-style-type: none"> 1. Tooth coarse for work 2. Too heavy feed / too slow feed 3. Vibrating work place 4. Gullets loading 	<ol style="list-style-type: none"> 1. Use finer tooth blade 2. Increase feed pressure and / or speed 3. Clamp work securely 4. Use coarse tooth blade or brush to remove chips
Motor Running Too Hot	<ol style="list-style-type: none"> 1. Blade tension too high 2. Drive belt tension too high 3. Blade is too coarse for work (pipes specially) 4. Blade is too fine for work (heavier, soft material) 5. Gear not aligned properly 6. Gears need lubrication 7. Idler wheel needs lubrication 	<ol style="list-style-type: none"> 1. Reduce tension on blade 2. Reduce tension on drive belt 3. Use finer blade 4. Use coarse blade 5. Adjust gears so that worm is in center of gear 6. Check oil bath 7. Oil bearing / shaft on idler wheel

CX109 PARTS BREAKDOWN

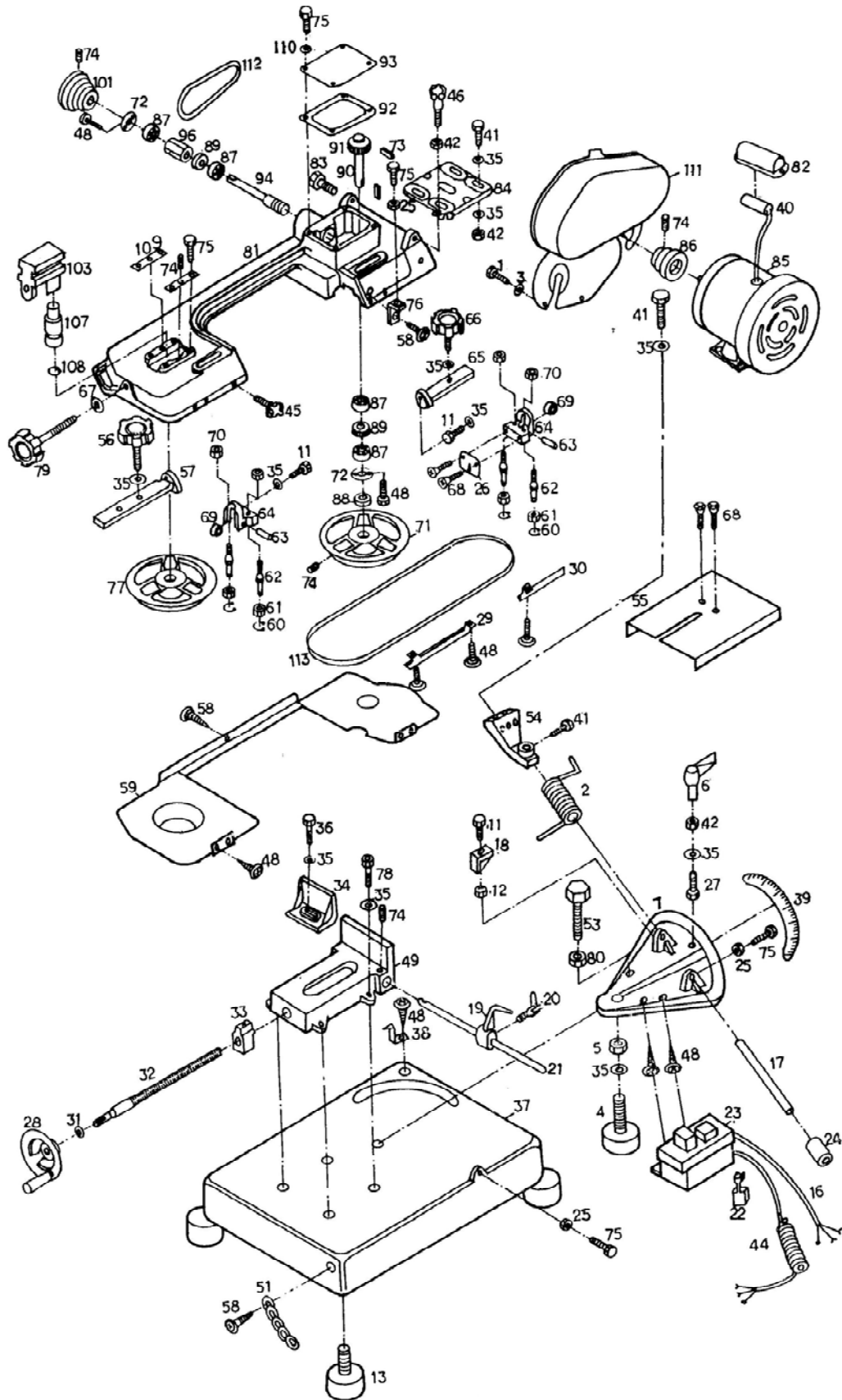

CX109

PARTS BREAKDOWN

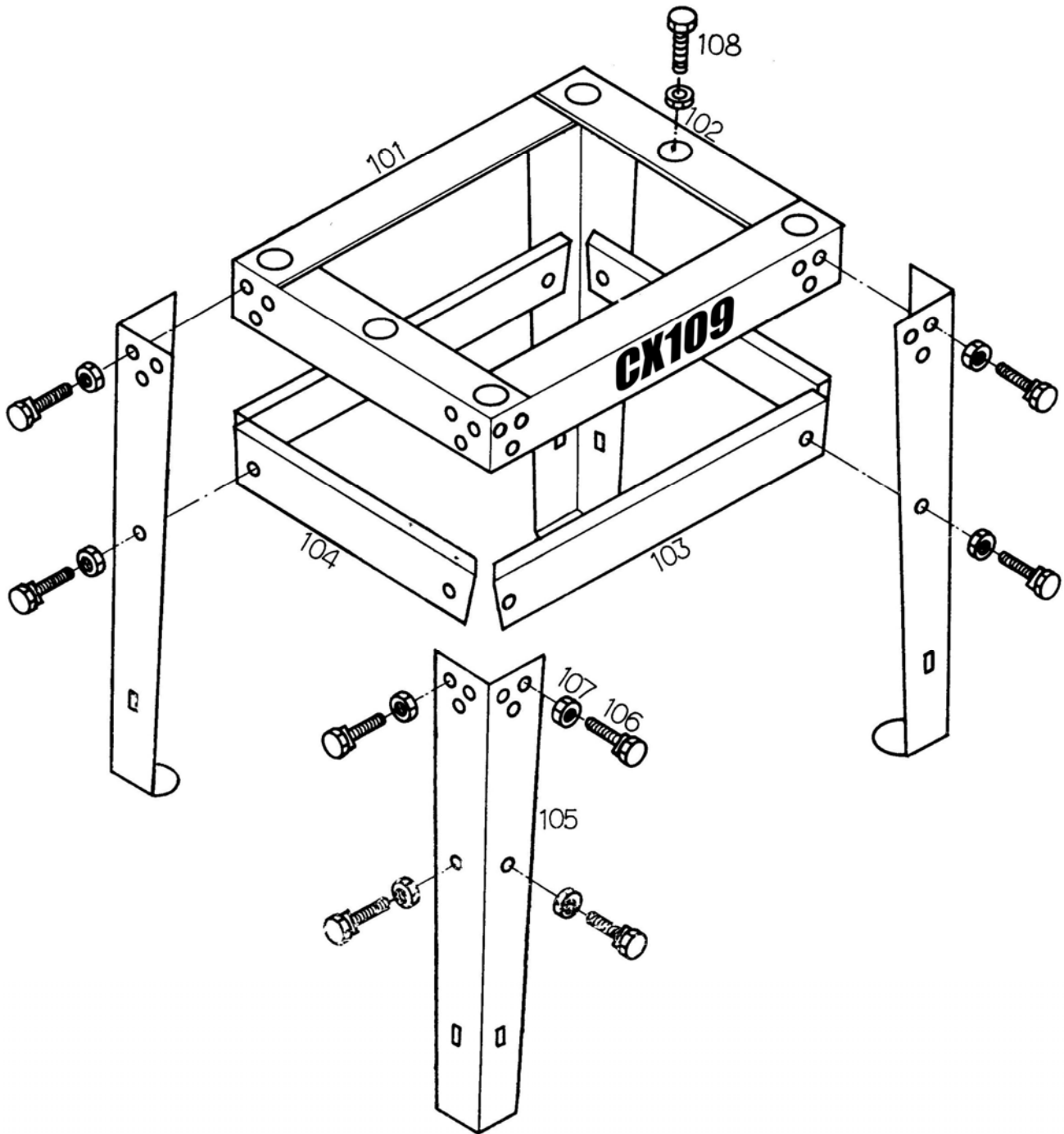

CX109 PARTS LIST

NO.	DESCRIPTION	QTY	NO.	DESCRIPTION	QTY
1.	HEX. HEAD SCREW	2	58.	SCREW	3
2.	SPRING	1	59.	BLADE COVER	1
3.	WASHER	2	60.	C-RING	4
4.	BOLT, (MITER PLATE)	1	61.	BEARING	4
5.	NUT	1	62.	GUIDE PIVOT	4
6.	FIXING LEVER	1	63.	BEARING SHAFT PIN	2
7.	MITER PLATE	1	64.	BLADE SEAT	2
11.	HEX. HEAD SCREW	3	65.	BLADE GUIDE BRACKET, R	1
12.	HEX. NUT	1	66.	BRACKET LOCK, R	1
13.	PAD, (BASE)	4	67.	WASHER	1
16.	ELECTRIC CABLE	1	68.	SCREW	2
17.	ROD	1	69.	BEARING (608)	2
18.	SUPPORT PLATE	1	70.	HEX, NUT	4
19.	STOCK STOP	1	71.	DRIVE BLADE WHEEL	1
20.	THUMB SCREW	1	72.	BEARING COVER	1
21.	ROD, STOCK STOP	1	73.	KEY	2
22.	WIRE RELIEF RETAINER	3	74.	HEX. SET SCREW	6
23.	SWITCH	1	75.	HEX. HEAD SCREW	11
24.	BUSHING	1	76.	SWITCH CUT OFF TIP	1
25.	HEX. NUT	1	77.	IDLE BLADE WHEEL	1
26.	BLADE GUARD	1	78.	HEX. HEAD SCREW	4
27.	HEX. HEAD SCREW	1	79.	TENSION KNOB	1
28.	HAND WHEEL	1	80.	HEX. NUT	1
29.	BLADE COVER, L	1	81.	BODY FRAME	1
30.	BLADE COVER, R	1	82.	CONDENSER COVER	1
31.	C-RING	1	83.	SET SCREW	2
32.	LEAD SCREW	1	84.	MOTOR PLATE	1
33.	WISE NUT	1	85.	MOTOR	1
34.	CLAMPING PLATE, VISE	1	86.	MOTOR PULLEY	1
35.	WASHER	15	87.	BALL BEARING (6202Z)	4
36.	HEX. HEAD SCREW	1	88.	BUSHING	1
37.	BASE	1	89.	OIL SEAL	2
38.	ANGLE POINTER	1	90.	TRANSMISSION GEAR SHAFT	1
39.	SCALE	1	91.	TRANSMISSION GEAR	1
40.	CONDENSER, (MOTOR)	1	92.	GASKET, GEAR BOX	1
41.	HEX. HEAD SCREW	1	93.	GEAR BOX COVER	1
42.	HEX. NUT	5	94.	WORM GEAR	1
44.	ELECTRICAL CABLE	1	96.	BUSHING	1
45.	KNOB	1	101.	GEAR PULLEY	1
46.	KNOB	1	103.	BLOCK, BLADE TENSION	1
48.	SET SCREW	13	107.	WHEEL SHAFT	1
49.	WISE BASE	1	108.	C-RING	1
51.	LOCKING CHAIN	1	109.	TRACKING PLATE	2
53.	HEX. HEAD SCREW	1	110.	SPRING WASHER	4
54.	ARM	1	111.	PULLEY CASE	1
55.	VERTICAL CUTTING TABLE	1	112.	V-BELT (A22)	1
56.	BRACKET LOCK, L	1	113.	SAWBLADE	1
57.	BLADE GUIDE BRACKET, L	1			



WARRANTY

CRAFTEX 3 YEAR LIMITED WARRANTY

Craftex warrants every product to be free from defects in materials and agrees to correct such defects where applicable. This warranty covers **three years** for parts and 90 days for labour (unless specified otherwise), to the original purchaser from the date of purchase but does not apply to malfunctions arising directly or indirectly from misuse, abuse, improper installation or assembly, negligence, accidents, repairs or alterations or lack of maintenance.

Proof of purchase is necessary.

All warranty claims are subject to inspection of such products or part thereof and Craftex reserves the right to inspect any returned item before a refund or replacement may be issued.

This warranty shall not apply to consumable products such as blades, bits, belts, cutters, chisels, punches etceteras.

Craftex shall in no event be liable for injuries, accidental or otherwise, death to persons or damage to property or for incidental contingent, special or consequential damages arising from the use of our products.

RETURNS, REPAIRS AND REPLACEMENTS

To return, repair, or replace a Craftex product, you must visit the appropriate Busy Bee Tools showroom or call 1-800-461-BUSY. Craftex is a brand of equipment that is exclusive to Busy Bee Tools.

For replacement parts directly from Busy Bee Tools, for this machine, please call 1-800-461-BUSY (2879), and have your credit card and part number handy.

- All returned merchandise will be subject to a minimum charge of 15% for re-stocking and handling with the following qualifications.
- Returns must be pre-authorized by us in writing.
- We do not accept *collect* shipments.
- Items returned for warranty purposes must be insured and shipped pre-paid to the nearest warehouse
- Returns must be accompanied with a copy of your original invoice as proof of purchase. Returns must be in an un-used condition and shipped in their original packaging a letter explaining your reason for the return. Incurred shipping and handling charges are not refundable.
- Busy Bee will repair or replace the item at our discretion and subject to our inspection.
- Repaired or replaced items will be returned to you pre-paid by our choice of carriers.
- Busy Bee reserves the right to refuse reimbursement or repairs or replacement if a third party without our prior authorization has carried out repairs to the item.
- Repairs made by Busy Bee are warranted for 30 days on parts and labour.
- Any unforeseen repair charges will be reported to you for acceptance prior to making the repairs.
- The Busy Bee Parts & Service Departments are fully equipped to do repairs on all products purchased from us with the exception of some products that require the return to their authorized repair depots. A Busy Bee representative will provide you with the necessary information to have this done.
- For faster service it is advisable to contact the nearest Busy Bee location for parts availability prior to bringing your product in for repairs.

