



CX205ST
SLIDING TABLE ATTACHMENT
FOR CX205 & CX206
Assembly Instructions



COPYRIGHT © 2010 BY CRAFTEX INDUSTRIES INC. NO PORTION OF THIS MANUAL MAY BE PRODUCED WITHOUT THE WRITTEN CONSENT OF CRAFTEX INDUSTRIES INC.



GENERAL SAFETY INSTRUCTIONS FOR MACHINES

Extreme caution should be used when operating all power tools. Know your power tool, be familiar with its operation, read through the user manual and practice safe usage procedures at all times.

- ❖ **ALWAYS** read and understand the user manual before operating the machine.
- ❖ **CONNECT** your machine ONLY to the matched and specific power source.
- ❖ **ALWAYS** wear safety glasses respirators, hearing protection and safety shoes, when operating your machine.
- ❖ **DO NOT** wear loose clothing or jewelry when operating your machine.
- ❖ **A SAFE ENVIRONMENT** is important. Keep the area free of dust, dirt and other debris in the immediate vicinity of your machine.
- ❖ **BE ALERT! DO NOT** use prescription or other drugs that may affect your ability or judgment to safely use your machine.
- ❖ **DISCONNECT** the power source when changing drill bits, hollow chisels, router bits, shaper heads, blades, knives or making other adjustments or repairs.
- ❖ **NEVER** leave a tool unattended while it is in operation.
- ❖ **NEVER** reach over the table when the tool is in operation.
- ❖ **ALWAYS** keep blades, knives and bits sharpened and properly aligned.
- ❖ **ALL OPERATIONS MUST BE** performed with the guards in place to ensure safety.
- ❖ **ALWAYS** use push sticks and feather boards to safely feed your work through the machine and clamp the work-piece (when necessary) to prevent the work-piece from any unexpected movement.
- ❖ **ALWAYS** make sure that any tools used for adjustments are removed before operating the machine.
- ❖ **ALWAYS** keep the bystanders safely away while the machine is in operation.
- ❖ **NEVER** attempt to remove jammed cutoff pieces until the saw blade has come to a full stop.

SETUP

Before setting up your sliding table you should read and understand the instructions given in this manual.

WARNING

Before assembling the sliding table on your table saw, make sure the switch is in the "OFF" position and the power cord is disconnected from the power source. Failure to do so may cause serious personal injury or death.

UNPACKING

The sliding table is properly packaged and shipped completely in a crate for safe transportation. When unpacking, carefully inspect the crates and ensure that nothing has been damaged during transit. Open the crates and check that the table and the parts are in good condition.

IMPORTANT

We recommend that when using this sliding table with your CX205 or CX206, the machine should either be bolted down or counterweighted for added safety.

Extended Bracket for CX205

The sliding table comes with an extended bracket for CX205. When installing the sliding table on CX205, you will need to

install the extended bracket to the saw cabinet first. See figure-1.

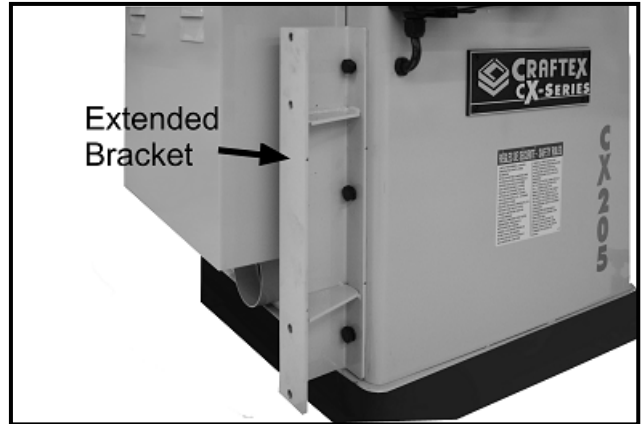

Figure-1 Extended bracket for CX205

ASSEMBLY

Attach the two brackets to the table saw cabinet (when installing on CX206) or to the extended bracket (when installing on CX205) and secure them using screws and lock washers provided.

Make sure the bracket with the adjustment screws on it (part# 38), is attached to the top and the bracket with spherical bearing (part# 44), at the bottom. See figure-2.

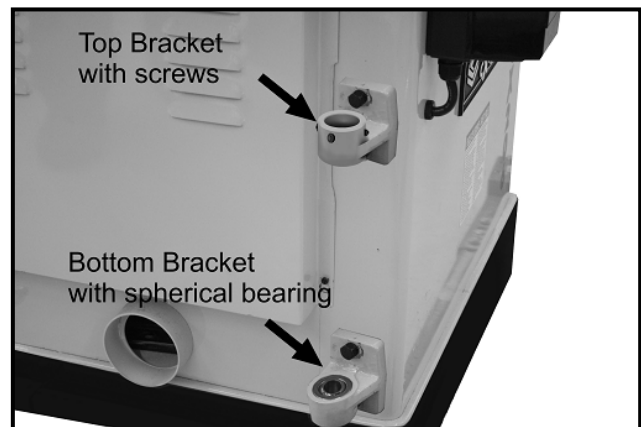

Figure-2 Top and bottom brackets

Now, hold the swinging arm (part# 40) between the top and bottom brackets, with the holes aligned and insert the shaft (part# 41) from the top, through the holes to secure the swinging arm. See figure-3.

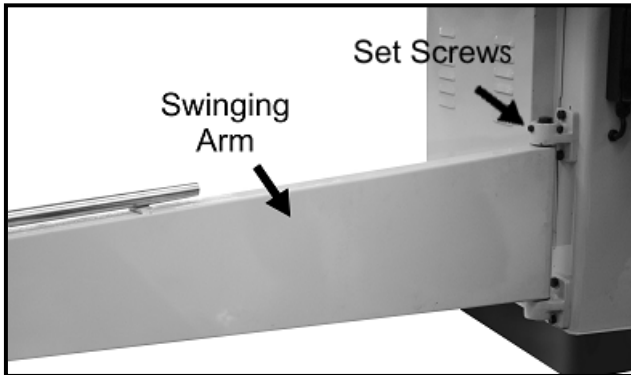

Figure-3 Installing the swinging arm

Adjust 3 set screws (part# 7) located on the top bracket as shown in figure-3 so that the shaft is in the center.

Install brackets (part#12) to the table as shown in figure-4 using screws and washers provided.

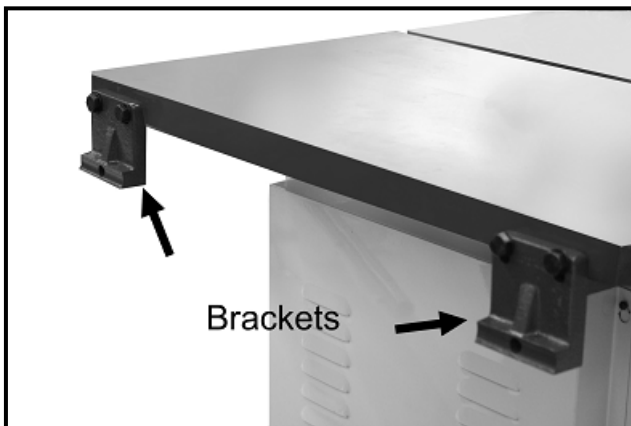

Figure-4 Installing steel rod brackets

Now, align the holes on the steel rod (part# 11) with the holes on the bracket and attach the steel rod to the brackets and secure it using socket screws and washers provided.

Slide the rear stop ring (part# 17) on to the left hand end of the steel rod and secure it by tightening the set screw on it.

Slide the front stop ring (part# 16) shaft into the support rod (part# 33) and secure it by tightening the lock knob (part# 34).

Now, slide the front stop ring onto the right hand end of the steel rod and secure it by tightening the set screw.

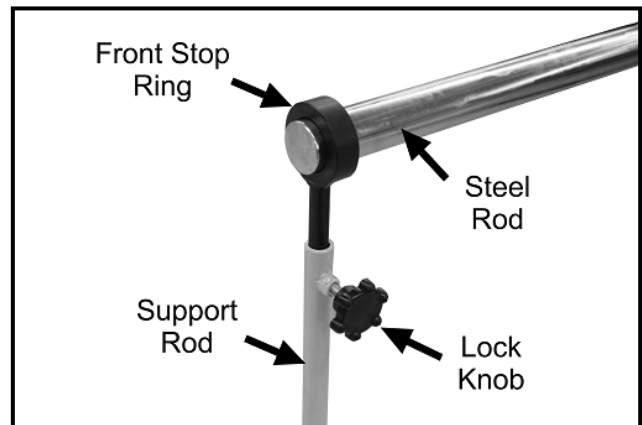

Figure-5 Installing front stop ring onto the steel rod

Take the main table (part# 1) and put it up side down on the floor. Attach the Y-arm to the main table as shown in figure-6 securing it using screws and washers.

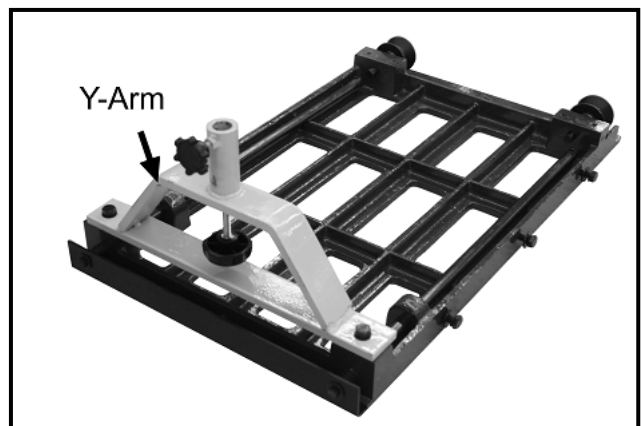

Figure-6 Y-arm attached to the main table

Insert the sliding roller (part# 37) shaft into the Y-arm as shown in figure-7 and tighten the lock knob (part# 49).

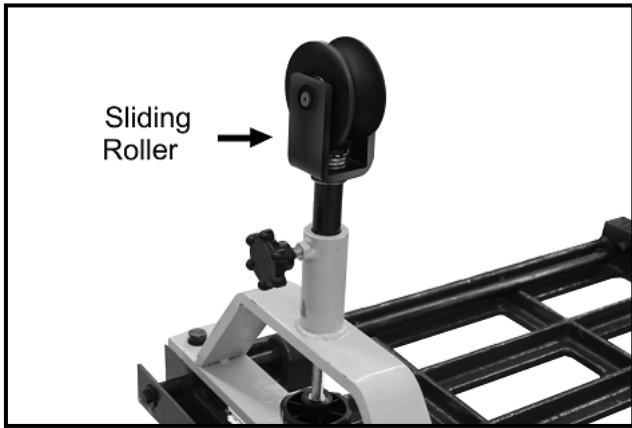

Figure-7 Attaching sliding roller

Attach the extension table (part# 20) to the main table as shown in figure-8 using 3 M10 hex head screws and washers provided.

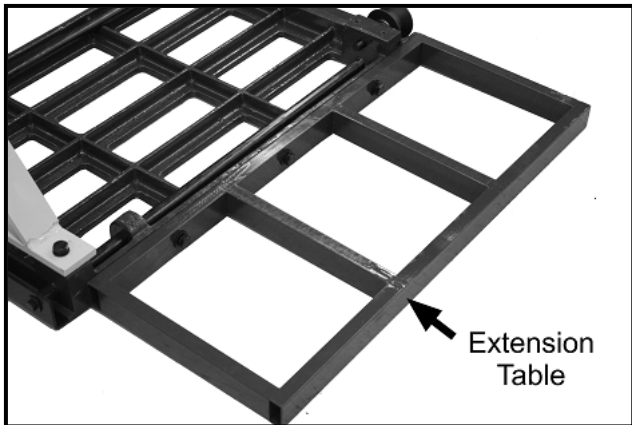

Figure-8 Attaching the extension table to the main table

Now, turn the main table upright with the extension table and place it on the swinging arm (part# 40) and the steel rod (part# 11) in such a way that the upper rollers (part# 21) slide on the steel rod and the sliding

roller (part# 37) slide on the rod attached to the swinging arm. See figure-9.

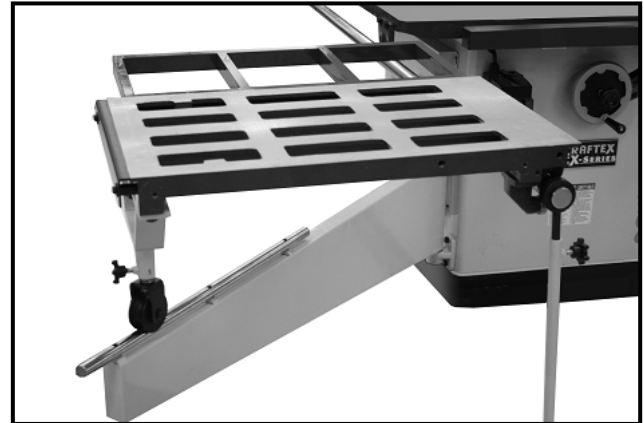

Figure-9 Installing the table on the rollers

Attach the two lower roller supports (part# 15) to the bottom of the main table (part# 1) as shown in figure-10, using screws and washer provided.

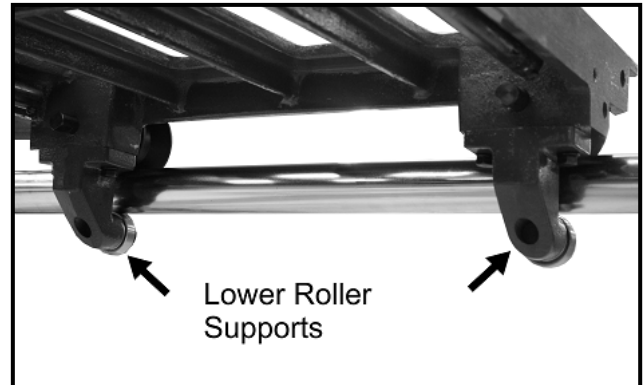

Figure-10 Installing the lower roller supports

Once the lower supports are installed, it is then time for adjustments.

ADJUSTMENTS:

Place a straight-edge across the saw table and the sliding table as shown in figure-11. Loosen the knob (part# 34) on the support rod and raise / lower the steel rod (part# 11), so that the sliding table is at the same

height with the saw table. Re-tighten the knob.

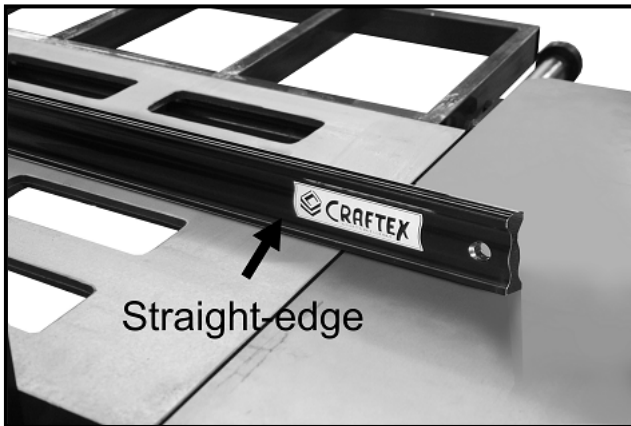

Figure-11 Adjusting the sliding table height equal to saw table using straight-edge

Place the straight edge on the sliding table and the saw table as shown in figure-12.

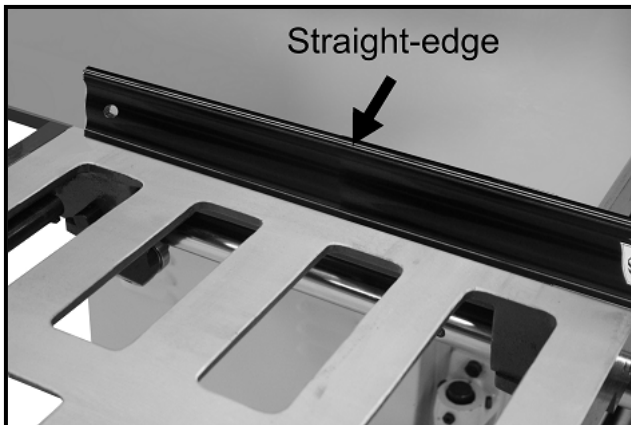

Figure-12 Placing straight-edge on the sliding table and saw table

Now, loosen the lock screws shown in figure-13 securing the upper roller shafts (part# 14) on both sides on the sliding table. Turn the roller shaft using a proper sized wrench to adjust the roller height and re-tighten the lock screws.

Make sure there is approximately 0.5 cm gap between the edge of the sliding table and the edge of the saw table so that the sliding table can slide smoothly.

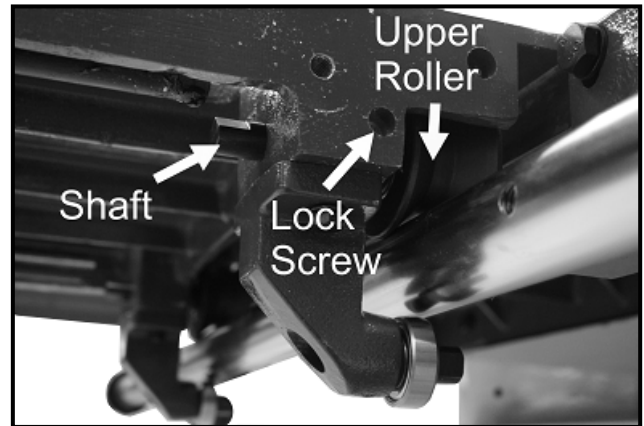

Figure-13 Adjusting the roller shaft

Place the straight edge on the table as shown in figure-12 and loosen the lock knob (part# 49) on the Y-arm (part# 31).

Loosen the lock nut (part# 36) and turn the adjustment knob (part# 32) to raise or lower the Y-arm. Once the sliding table is at the correct height with the saw table, slide the sliding table on the steel rod. Make sure the table is sliding smoothly on the steel rod and retighten the lock nut and the lock knob. See figure-14.

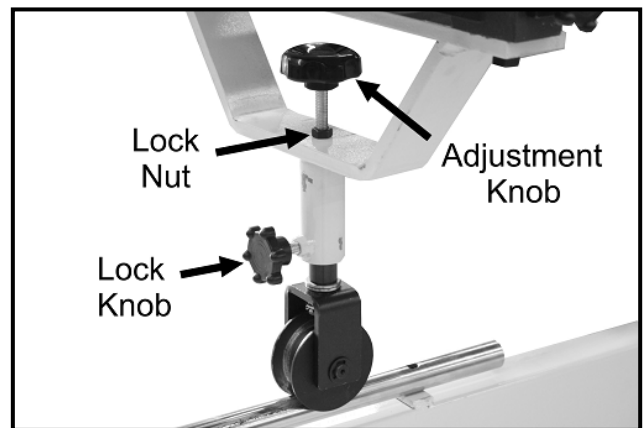

Figure-14 Adjusting the Y-arm height

Loosen the screws securing the lower support bearings shaft (part# 23) as shown in figure-15.

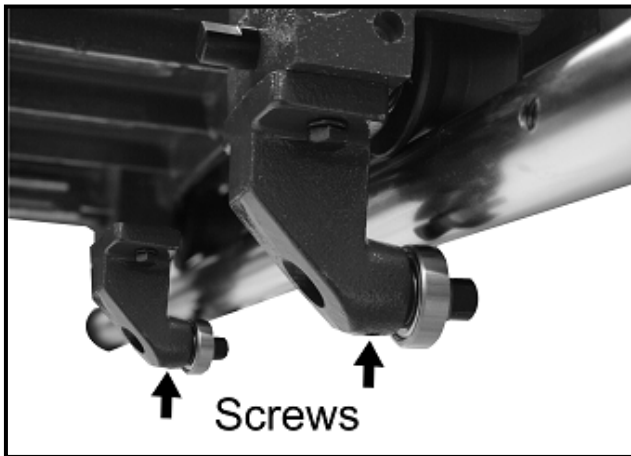

Figure-15 Adjusting the lower support bearings

Rotate the bearing shaft so that the lower bearing just touches the steel rod and re-tighten the screw.

Attach the fence brackets (part# 18) to the sliding table as shown in figure-16 and secure the fence (part# 24) to the brackets using nuts, bolts and washers provided.

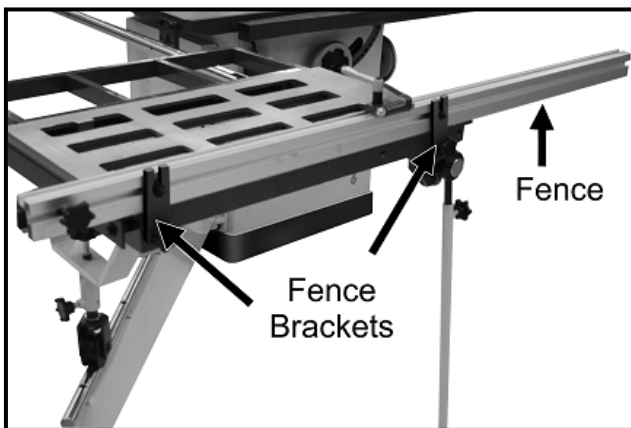

Figure-16 Installing the fence

Attach the flip stop (part# 4) to the fence through the miter slot and turn the lock handle to secure it.

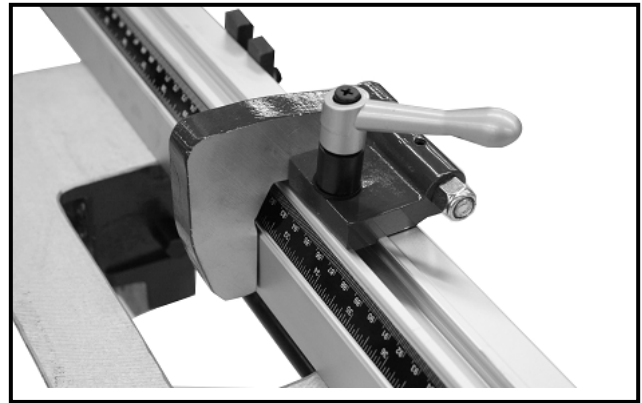

Figure-17 Installing the flip stop

Insert the extension tube (part# 25) into the fence and install the stop (part# 48) onto the extension tube. Lock the extension tube using the lock knob as shown in figure-18.

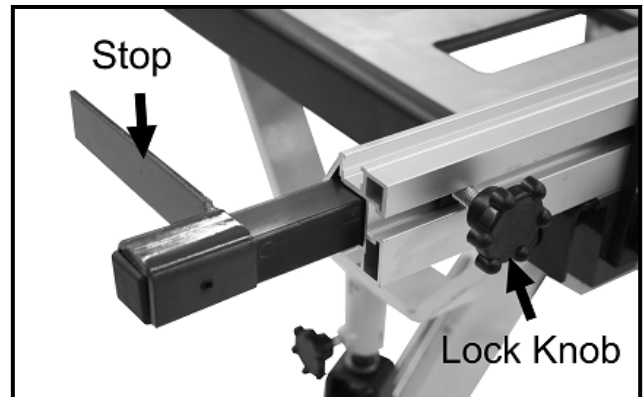
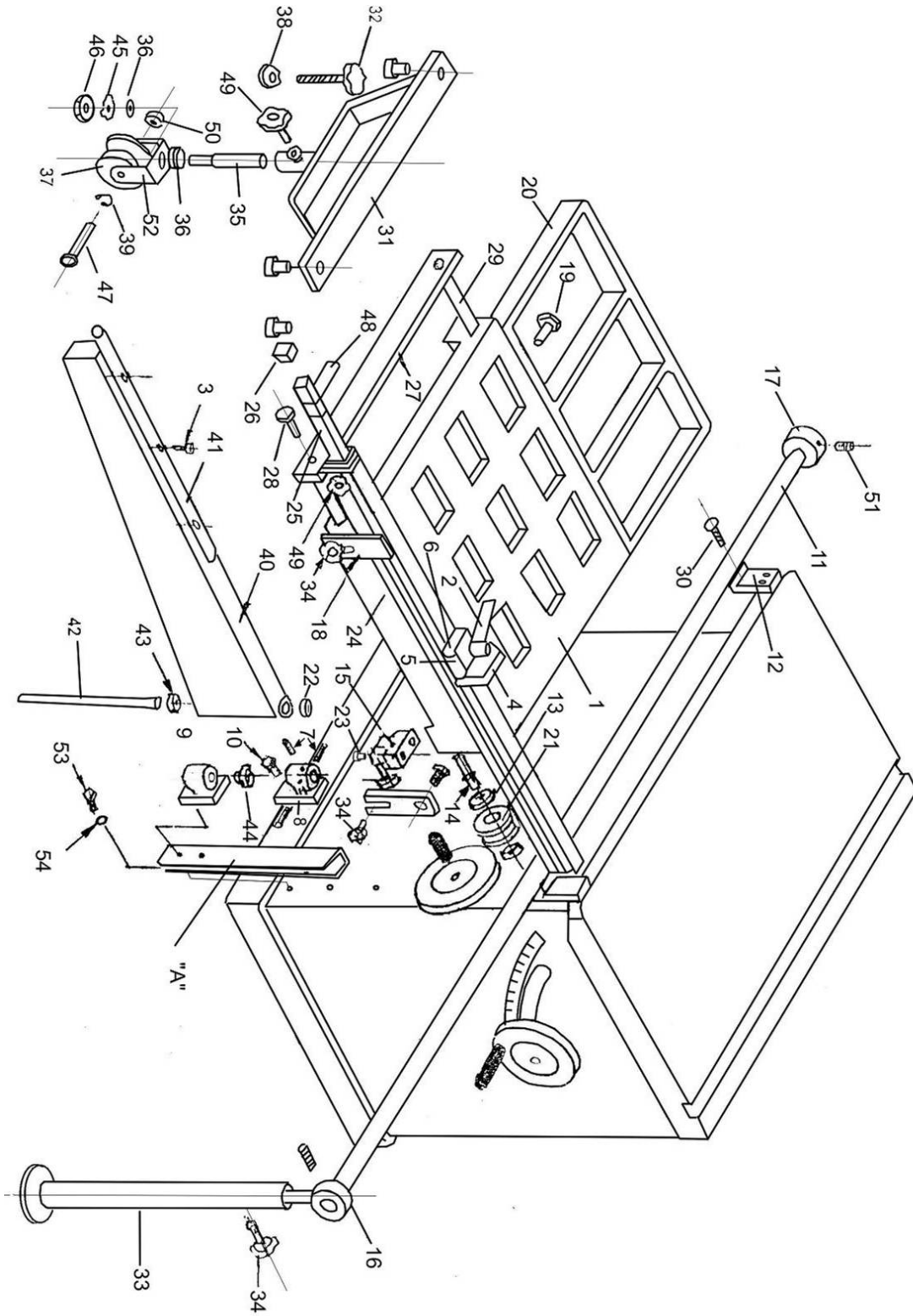

Figure-17 Installing the stop to the fence

Once the assembly is done, slide the table and check if the sliding table slides smoothly.

Adjust the sliding table height, turning the bearing shafts (part# 14) on the two upper rollers and adjust the sliding roller (part# 37) height, turning the adjustment knob (part# 32) if needed. **See page-5 for details on ADJUSTMENTS.**

CX205ST PARTS BREAKDOWN



CX205ST PARTS LIST

REF #	DESCRIPTION	QTY	REF #	DESCRIPTION	QTY
1	Main Table	1	28	M8. Hex HD Screw	2
2	Lock Handle	1	29	Extension Bar	2
3	Socket Screw	3	30	Socket Screw	2
4	Flip Stop	1	31	Y-Arm	1
5	Bracket	1	32	Adjustment Knob	1
6	Round Pin	1	33	Support Rod	1
7	Set Screw M8	3	34	Lock Knob	1
8	Upper Bracket	1	35	Shaft	1
9	Lower Bracket	1	36	Lock Nut	2
10	M10. Hex HD Screw	4	37	Sliding Roller	1
11	Steel Rod	1	38	Nut	1
12	Bracket	2	39	"E" Type Ring	3
13	Bearing	4	40	Swinging Arm	1
14	Roller Shaft	2	41	Round Bar	1
15	Lower Roller Support	2	42	Shaft	1
16	Front Stop Ring	1	43	Bearing	2
17	Rear Stop Ring	1	44	Spherical Bearing	1
18	Bracket	2	45	Washer	1
19	M10. Hex HD Screw	3	46	Lock Nut	1
20	Extension Table	1	47	Roller Pin	1
21	Upper Roller	2	48	Stop	1
22	Bearing	2	49	Lock Knob	2
22-1	Breaing Shaft	2	50	Bearing # 6001ZZ	2
23	M8. Hex HD Screw	4	51	Set Screw M8	2
24	Fence	1	52	Roller Support	1
24-1	Tape Scale	1	53	M10. Hex HD. Screw	3
25	Extension Tube	1	54	M10. Lock Washer	3
26	End Cover	1	"A"	Extended Bracket	1
27	Connecting Plate	1			



WARRANTY

CRAFTEX 3 YEARS LIMITED WARRANTY

Craftex warrants every product to be free from defects in materials and agrees to correct such defects where applicable. This warranty covers **three years** for parts and 90 days for labour (unless specified otherwise), to the original purchaser from the date of purchase but does not apply to malfunctions arising directly or indirectly from misuse, abuse, improper installation or assembly, negligence, accidents, repairs or alterations or lack of maintenance.

Proof of purchase is necessary.

All warranty claims are subject to inspection of such products or part thereof and Craftex reserves the right to inspect any returned item before a refund or replacement may be issued.

This warranty shall not apply to consumable products such as blades, bits, belts, cutters, chisels, punches etceteras.

Craftex shall in no event be liable for injuries, accidental or otherwise, death to persons or damage to property or for incidental contingent, special or consequential damages arising from the use of our products.

RETURNS, REPAIRS AND REPLACEMENTS

To return, repair, or replace a Craftex product, you must visit the appropriate Busy Bee Tools showroom or call 1-800-461-BUSY. Craftex is a brand of equipment that is exclusive to Busy Bee Tools.

For replacement parts directly from Busy Bee Tools, for this machine, please call 1-800-461-BUSY (2879), and have your credit card and part number handy.

- All returned merchandise will be subject to a minimum charge of 15% for re-stocking and handling with the following qualifications.
- Returns must be pre-authorized by us in writing.
- We do not accept *collect* shipments.
- Items returned for warranty purposes must be insured and shipped pre-paid to the nearest warehouse
- Returns must be accompanied with a copy of your original invoice as proof of purchase. Returns must be in an un-used condition and shipped in their original packaging a letter explaining your reason for the return. Incurred shipping and handling charges are not refundable.
- Busy Bee will repair or replace the item at our discretion and subject to our inspection.
- Repaired or replaced items will be returned to you pre-paid by our choice of carriers.
- Busy Bee reserves the right to refuse reimbursement or repairs or replacement if a third party without our prior authorization has carried out repairs to the item.
- Repairs made by Busy Bee are warranted for 30 days on parts and labour.
- Any unforeseen repair charges will be reported to you for acceptance prior to making the repairs.
- The Busy Bee Parts & Service Departments are fully equipped to do repairs on all products purchased from us with the exception of some products that require the return to their authorized repair depots. A Busy Bee representative will provide you with the necessary information to have this done.
- For faster service it is advisable to contact the nearest Busy Bee location for parts availability prior to bringing your product in for repairs.