



CX405

2-HP DUST COLLECTOR

User Manual



TABLE OF CONTENTS

| | |
|---|----|
| General Safety Instructions..... | 3 |
| CX405 Specific Safety Instructions..... | 4 |
| Features..... | 5 |
| Physical Features | 6 |
| Unpacking..... | 7 |
| Setup | 7 |
| Proper Grounding | 8 |
| Assembly | 9 |
| Test Run | 11 |
| Operation | 12 |
| Maintenance | 12 |
| Bag Cleaning | 12 |
| Cleaning the Canister | 12 |
| Lubrication | 12 |
| Parts Breakdown | 13 |
| Parts List..... | 14 |
| Warranty | 15 |

GENERAL SAFETY INSTRUCTIONS

Extreme caution should be used when operating all power tools. Know your power tool, be familiar with its operation, read through the owner's manual and practice safe usage procedures at all times.

- ❖ **CONNECT** your machine only to the matched and specific power source.
- ❖ **ALWAYS** wear safety glasses respirators, hearing protection and safety shoes, when operating your machine.
- ❖ **DO NOT** wear loose clothing or jewelry when operating your machine.
- ❖ **GROUND ALL TOOLS** if tool is equipped with three-prong plug, it should be plugged into a three-hole electrical receptacle. If an adapter is used to accommodate a two-prong receptacle, the adapter plug must be attached to a known ground. Never remove the third prong.
- ❖ **A SAFE ENVIRONMENT** is important. Keep the area free of dust, dirt and other debris in the immediate vicinity of your machine.
- ❖ **KEEP CHILDREN AND VISITORS AWAY.** All children and visitors should be kept a safe distance from work area.
- ❖ **NEVER** leave a tool unattended while the machine is in operation.
- ❖ **DON'T OVERREACH.** Keep proper footing and balance at all times.
- ❖ **DISCONNECT** the machine from the power source when changing drill bits, hollow chisels, router bits, shaper heads, blades, knives, or making other adjustments or repairs.
- ❖ **SECURE WORK.** Use clamps or a vise to hold work when practical. It's safer than using your hand and frees both hands to operate tool.
- ❖ **BE ALERT! DO NOT** use prescription or other drugs that may affect your ability or judgment to safely use your machine.
- ❖ **MAINTAIN TOOLS IN TOP CONDITION.** Always keep the blades sharp and aligned. Follow instructions given in the user manual for lubricating and changing accessories.
- ❖ **DISCONNECT TOOLS** before servicing and when changing accessories such as blades, bits, cutters, etc.
- ❖ **ALWAYS** keep all safety guards in place and ensure their proper function.
- ❖ The dust generated by certain woods and wood products can be injurious to your health. **ALWAYS** operate machinery in well ventilated areas use wood dust collection systems whenever possible.

CX405 – 2 HP DUST COLLECTOR SPECIFIC SAFETY INSTRUCTIONS

Read and understand the instruction manual before operating the dust collector. Basic precautions listed below should always be followed when using your dust collector to reduce the risk of injury, electrical shock or fire.

- ❖ The CX405 is designed to collect sawdust only.
- ❖ **NEVER** attempt to use this dust collector to vacuum water or any other liquids.
- ❖ **NEVER** try to use this dust collector to collect large wood pieces.
- ❖ **NEVER** attempt to use this dust collector to collect metal materials such as screws, nails or other metal parts.
- ❖ **ALWAYS** wear respiratory and safety glasses when emptying dust from the collection bags.
- ❖ **NEVER** operate the dust collector with all blast gates closed.
- ❖ **ALWAYS** disconnect the dust collector from its power source when changing or emptying the bags.
- ❖ **ALWAYS** be sure that the collection and filter bags are securely fastened to collector body.
- ❖ **DO NOT** place your hand or tools nears the open inlet while operation. Serious personal injury or damage to the machine can happen.
- ❖ **ALWAYS** connect dust collector to the matched power source.

IMPORTANT

The safety instructions given above can not be complete because the environment in every shop is different. Always consider safety first as it applies to your individual working conditions.



CX405 FEATURES

MODEL CX405 – 2 HP DUST COLLECTOR

As part of the growing line of Crafttex CX-Series woodworking equipment, we are proud to offer the CX405 a 2-HP Dust Collector. By following the instructions and procedures laid out in this owner's manual, you will receive years of excellent service and satisfaction. The CX405 is a professional tool and like all power tools, proper care and safety procedures should be adhered to.

- ❖ Motor2-HP, Single Phase 220 Volt, 12 Amps
- ❖ Switch..... ON/OFF Switch with Removable Key
- ❖ Balanced Steel Impeller..... Yes
- ❖ Impeller Size 12"
- ❖ Lower Bags..... Easy-On Bags
- ❖ Lower Bag Volume 11.10 Cubic Feet
- ❖ Upper Bags..... One-Micron Upper Filtration Bag
- ❖ Static Pressure 12"
- ❖ Air Suction Capacity 1,596 CFM
- ❖ Noise Level..... 77 dB
- ❖ Intakes..... Two 4"
- ❖ Foot Print..... 22" x 46"
- ❖ Mobile Base for Ease of Movement.....Yes
- ❖ Weight 61 Kg
- ❖ Warranty..... 3 Years

CX405 - 2-HP DUST COLLECTOR PHYSICAL FEATURES



UNPACKING

The dust collector is properly packaged in a carton for safe transportation. When unpacking, carefully inspect the carton and ensure that nothing has been damaged during transit.

While doing the inventory if you can not find any part, check if the part is already installed on the machine.

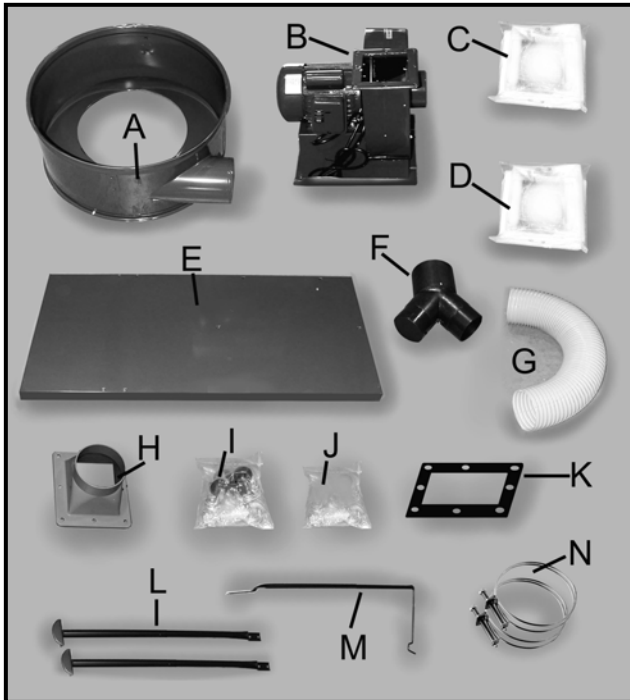

Figure-1 Inventory

CONTENTS

QTY

| | | |
|-----------|-------------------------------|---|
| A. | Collector Ring..... | 1 |
| B. | Motor / Impeller Unit..... | 1 |
| C. | Top Bag..... | 1 |
| D. | Bottom Bag | 1 |
| | Easy-On Bottom Bags..... | 5 |
| E. | Base Unit..... | 1 |
| F. | Dual Intake 4" Each..... | 1 |
| G. | Hose..... | 1 |
| H. | Outlet Connector | 1 |
| I. | Casters..... | 4 |
| J. | Hardware Bag | 1 |
| K. | Gasket..... | 1 |
| L. | Collector Ring Supports | 2 |
| M. | Top Bag Supports | 1 |
| N. | Hose Clamps..... | 2 |

SETUP

Before setting up your machine you need to read and understand this user manual completely.

The CX405 features four casters installed to its base unit for easy mobility. If you want to use the CX405 as a stationary tool, do not install the casters and find an ideal spot where your dust collector will most likely be positioned.

Consider your complete work environment before placing your machine in the ideal spot.

PROPER GROUNDING

Grounding provides a path of least resistance for electric current to reduce the risk of electric shock.

CX405 is for use on a normal 220 volt circuit. Make sure that the machine is connected to an outlet having the same configuration as the plug. If an adaptor plug is used, it must be attached to the metal screw of the receptacle. To prevent electrical hazards, have a qualified electrician ensure that the line is properly wired.

The dust collector should be wired with a plug having 3 prongs to fit a 3 prong grounded receptacle as shown in figure-2. Do not remove the grounding prong to fit it into a 2 pronged outlet.

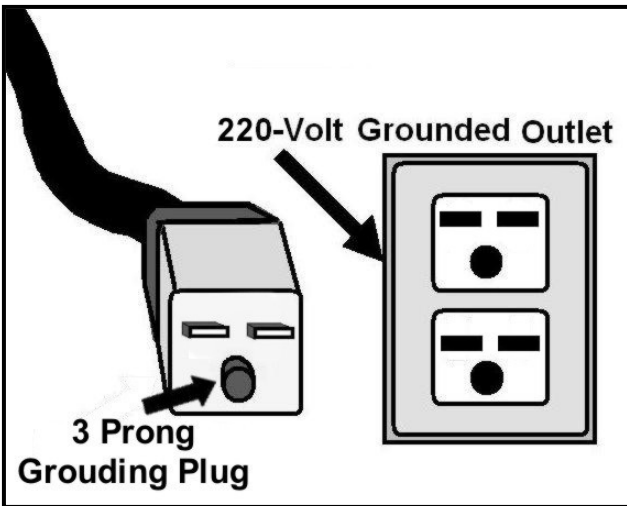

Figure-2 220-Volts outlet for CX405

WARNING

Improper connection of the equipment-grounding conductor can result in a risk of electric shock. Check with a qualified electrician if you are in doubt as to whether the outlet is properly grounded.

It is strongly recommended not to use extension cords with your CX405. Always try to position your machine close to the power source so that you do not need to use extension cords.

In case if you really find it necessary to use an extension cord, make sure the extension cord does not exceed 50-feet in length and the cord is 14-gauge to prevent motor damage.

ASSEMBLY

Follow the instructions below to assemble your CX405.

Place the base unit upside down and install the swivel casters to the base unit using screws, nuts and washers provided. See figure-3.

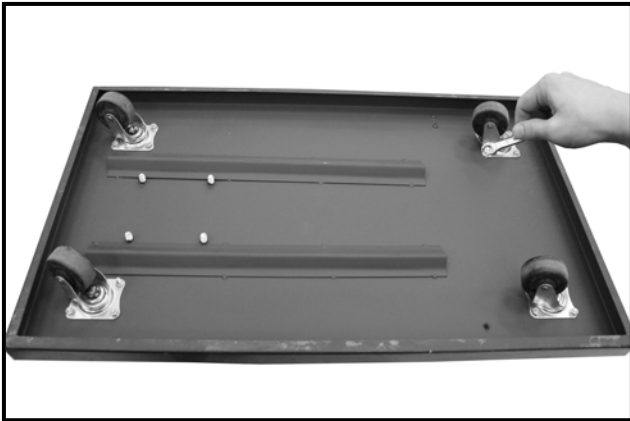

Figure-3 Installing the casters

Turn the base unit upright and position the motor / impeller unit on the base unit with the holes on both units aligned with each other. Secure the motor / impeller unit to the base unit using screws and washers provided. See figure-4.

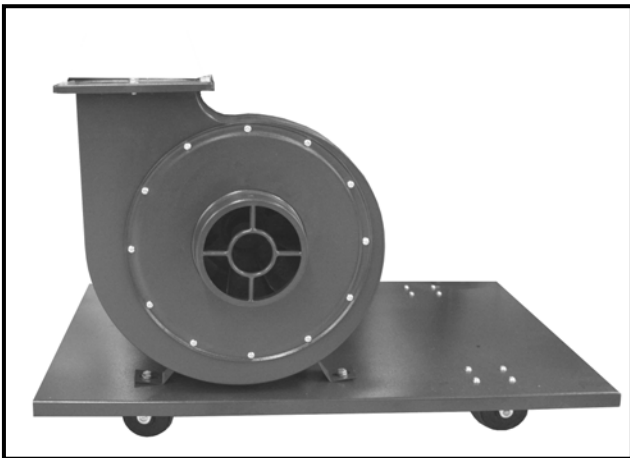

Figure-4 Installing the motor / impeller unit on the base unit

Place the gasket on the motor / impeller opening as shown in figure-5.

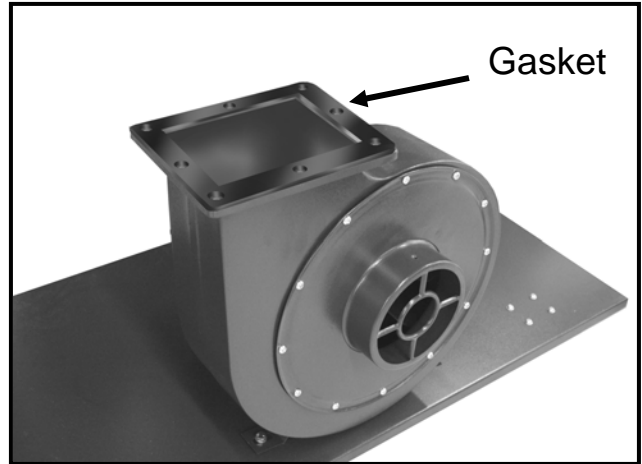

Figure-5 Positioning the gasket

Position the outlet connector onto the gasket and the motor / impeller opening securing it using screws and washers provided. See figure-6.

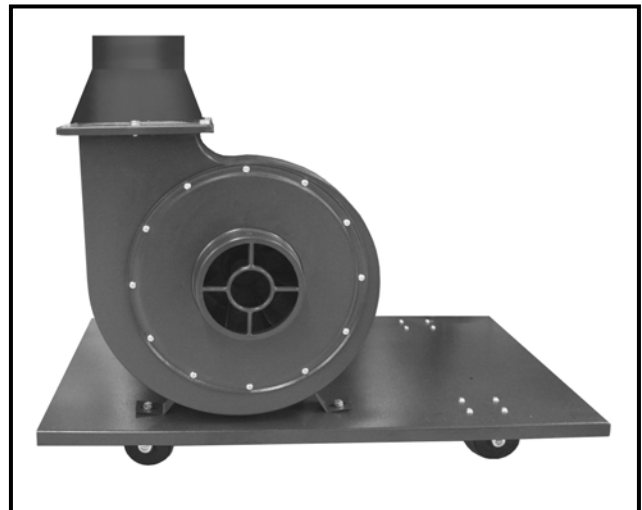

Figure-6 Installing the outlet connector

Attach the two collector ring supports to the base unit and secure them using screws, nuts and washers provided. See figure-7.

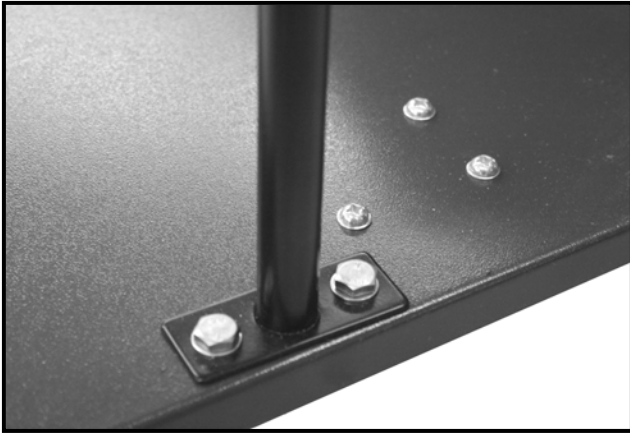

Figure-7 Installing the collector ring support

Attach the collector ring to the collector ring supports and the upper bag support to the collector ring as shown in figure-8. Make sure that the hose opening of the collector ring is facing the motor / impeller.

Secure the collector ring from both sides using screws, nuts, and washers provided.



Figure-8 Installing the collector ring and the upper bag support

Take the hose provided and attach it with its one to the outlet connector and the other end to the collector ring. See figure-9.

Use the hose clamps provided to secure the hose on both ends.

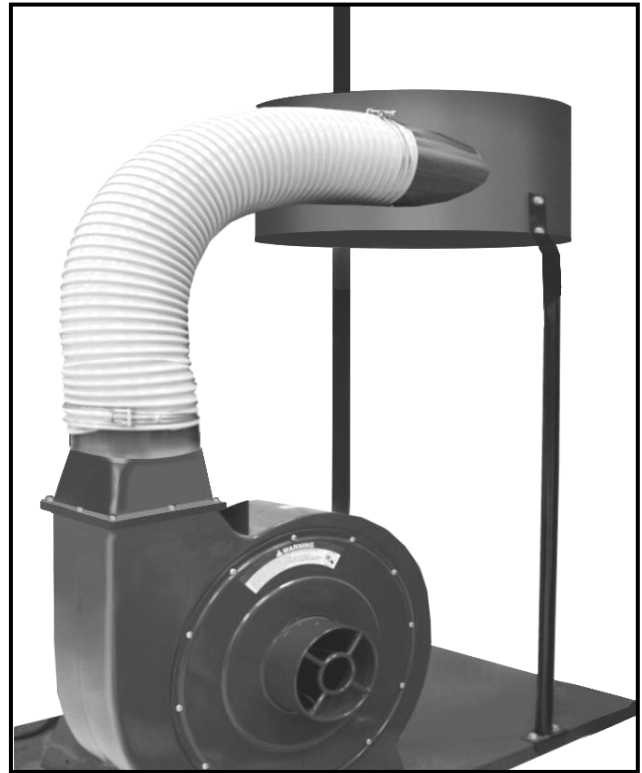

Figure-9 Connecting the hose from the outlet connector to the collector ring

Hang the top bag from the support and install it around the collector ring. Secure it using bag clamp provided.



Figure-10 Installing the top bag

Your dust collector should come with a regular bottom bag as well as a set of Easy-On bags.

Insert the belt clamp through the Easy-On bottom bag and attach the bottom bag to the dust collector as shown in figure-11.

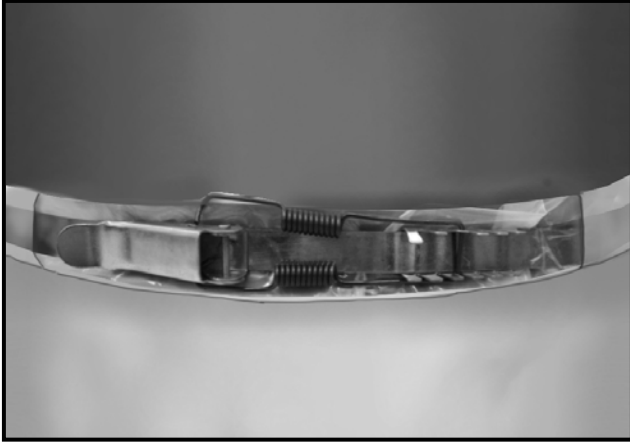

Figure-11 Installing the bottom bag

Attach the dual intake onto the motor/impeller opening as shown in figure-12 and secure it using screw provided.

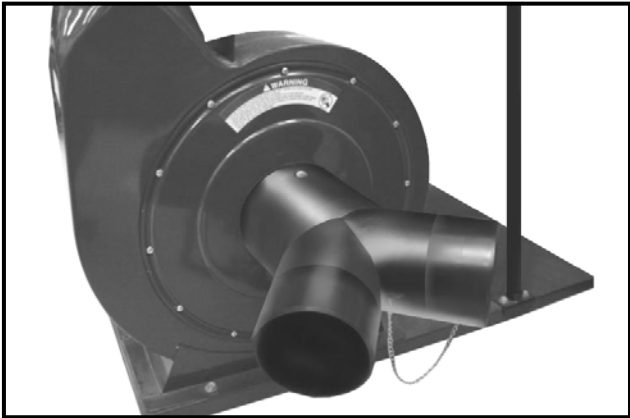

Figure-12 Installing the dual intake

The dual intake has a 4" cover cap, in case only one intake is used.

TEST RUN

Once you have assembled your dust collector, it is then time for a test run to make sure that the machine works properly and is ready to use.

Remove all the tools used for assembling the machine components. Walk around the machine, ensure all nuts, bolts, and screws are tightened and the machine is properly assembled. Connect the cord to the power source and turn the machine ON.

During the test run if there is any unusual noise coming from the machine or the machine vibrates excessively, turn OFF the power switch immediately and disconnect the cord from the power source. Investigate if you can find out the problem with your machine.

WARNING

Before starting the machine, make sure that you have read and understood the user manual and you are familiar with the safety features of the machine. Failure to do so may cause serious personal injury.

WARNING

Do not make any adjustments while the machine is running. Turn off the machine and un-plug from the power source before making any adjustments.

OPERATION

Operating the CX405 dust collector is very simple and straightforward.

Make sure the dust collector is properly assembled and worked during the test run. Move the CX405 close to the machine and use a proper sized hose connecting the hose with its one end to the machine and the other end to the dust collector.

Make sure the connections are secured using hose clamps and connect the ducting ground and the dust collector is ready for operation.

WARNING

Do not use the CX405 for any other operation other than collecting sawdust. Failure to do so could result in malfunction of the machine and may void the warranty.

MAINTENANCE

Maintenance on this machine is fairly simple. Each time you use your dust collector, make sure to properly clean the bags and take a quick inventory of your machines performance. Check the dust collector regularly for loose bolts, screws, ensure the dust collection bag has no tears, and ensure all wires are in good condition.

BAG CLEANING

Empty the collection bag on a regular basis. The machine will run more efficiently if the collecting bag is emptied regularly.

Make sure the switch in the OFF position and the cord is disconnected from the power source.

Make sure you are wearing a respirator or dust mask while emptying the collection bag. The tiny dust particles in the air can be inhaled easily and is very injurious to health.

Since the CX405 is comes with Easy-On collection bag, you do not have to remove the clamp from the collection bag. Simply Un-clamp the bag and empty it.

Re-install the bag and clamp it.

CLEANING THE CANISTER (If using a canister)

The canister has a cleaning handle which allows for easy cleaning of the canister by simply rotating the handle. After each use, rotate the handle at least one full turn. The fins inside the canister will knock most of the dust into the lower collection bag.

Make sure not to clean the canister using water or compressed air which can damage the filtration pleats of the filter. Always use the cleaning handle.

LUBRICATION

CX405 comes equipped with shielded bearings which are permanently lubricated. So, there is not need to lubricate them.

WARNING

Do not make any adjustments while the machine is running. Turn off the machine and un-plug from the power source before making any adjustments.

CX405 DUST COLLECTOR PARTS BREAKDOWN

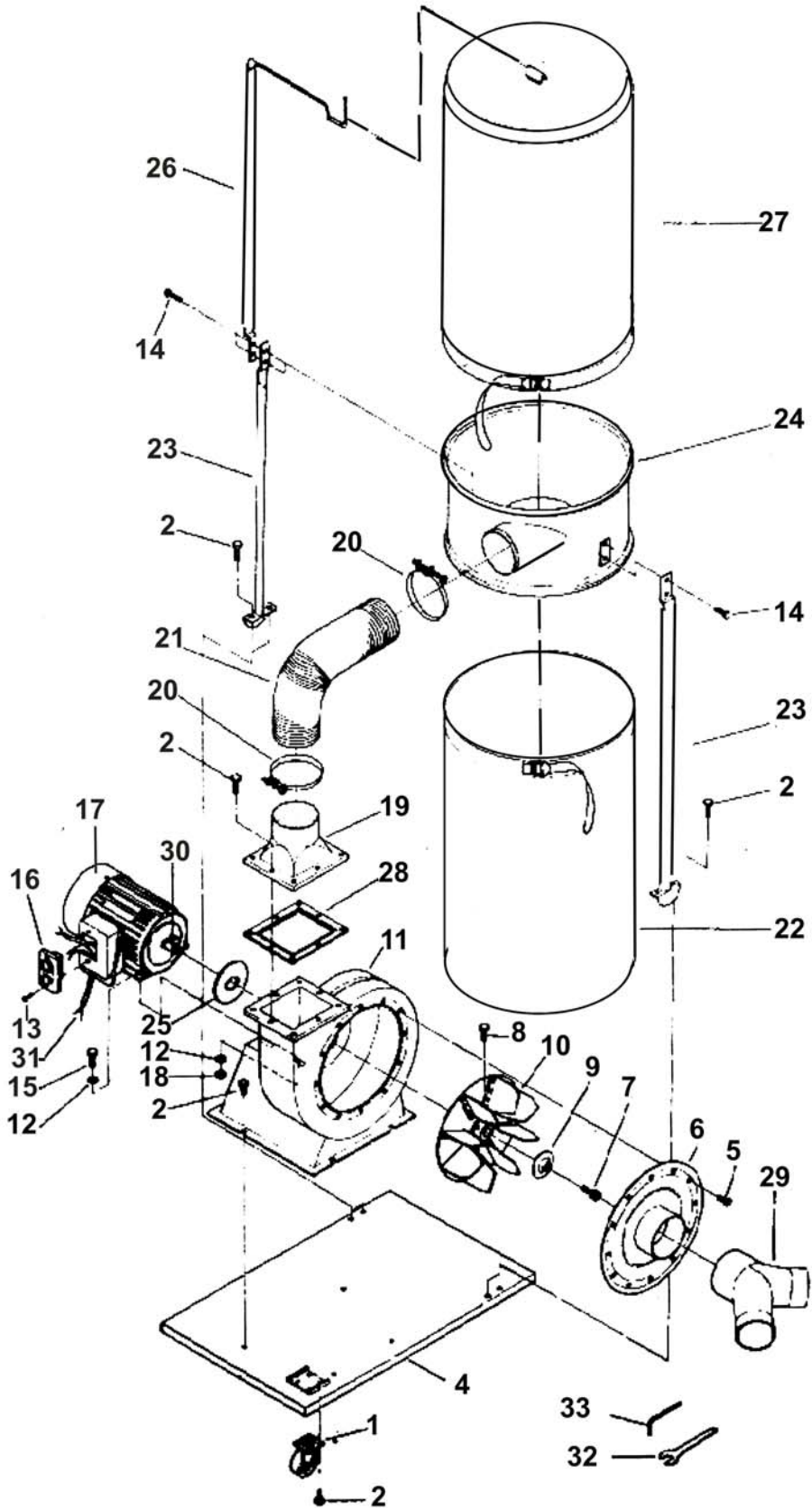

CX405 DUST COLLECTOR PARTS LIST

| PART# | DESCRIPTION | SIZE | QTY |
|-------|--------------------------|------------------|-----|
| 1 | Caster | | 4 |
| 2 | Hex Head Screw | 5/16 x 1/2" | 32 |
| 4 | Base Plate | | 1 |
| 5 | Pan Head Screw | 10 – 24 x 3/8" | 12 |
| 6 | Intake Cover | | 1 |
| 7 | Socket Head Hex Screw | 1.0 x 19mm | 1 |
| 8 | Hex Head Screw | 3/8 x 1/2" | 2 |
| 9 | Washer | | 1 |
| 10 | 12" Impeller Fan | | 1 |
| 11 | Impeller Body | | 1 |
| 12 | Washer | 5/16" | 8 |
| 13 | Pan Head Screw | 10 – 24 x 1" | 2 |
| 14 | Hex Head Screw | 5/16 x 3/4" | 4 |
| 15 | Hex Head Screw | 5/16 x 1" | 4 |
| 16 | Motor Switch | | 1 |
| 17 | Motor | | 1 |
| 18 | Nut | 5/16" | 4 |
| 19 | Collector Outlet Adapter | | 1 |
| 20 | Hose Clamp | 4" | 2 |
| 21 | Hose | 4" | 1 |
| 22 | Collector Bag | | 1 |
| 23 | Collector Support Posts | | 2 |
| 24 | Collector | | 1 |
| 25 | Gasket | | 1 |
| 26 | Filter Bag Support | | 1 |
| 27 | Cloth Filter Bag | | 1 |
| 28 | Gasket | | 1 |
| 29 | Dual 4" Intake | | 1 |
| 30 | Key | 7mm x 7mm x 29mm | 1 |
| 31 | Power Cord | | 1 |
| 32 | Open End Wrench | 12mm | 1 |
| 33 | Hex Wrench | 5mm | 1 |



WARRANTY

CRAFTEX 3 YEAR LIMITED WARRANTY

Craftex warrants every product to be free from defects in materials and agrees to correct such defects where applicable. This warranty covers **three years** for parts and 90 days for labour (unless specified otherwise), to the original purchaser from the date of purchase but does not apply to malfunctions arising directly or indirectly from misuse, abuse, improper installation or assembly, negligence, accidents, repairs or alterations or lack of maintenance.

Proof of purchase is necessary.

All warranty claims are subject to inspection of such products or part thereof and Craftex reserves the right to inspect any returned item before a refund or replacement may be issued.

This warranty shall not apply to consumable products such as blades, bits, belts, cutters, chisels, punches etceteras.

Craftex shall in no event be liable for injuries, accidental or otherwise, death to persons or damage to property or for incidental contingent, special or consequential damages arising from the use of our products.

RETURNS, REPAIRS AND REPLACEMENTS

To return, repair, or replace a Craftex product, you must visit the appropriate Busy Bee Tools showroom or call 1-800-461-BUSY. Craftex is a brand of equipment that is exclusive to Busy Bee Tools.

For replacement parts directly from Busy Bee Tools, for this machine, please call 1-800-461-BUSY (2879), and have your credit card and part number handy.

- All returned merchandise will be subject to a minimum charge of 15% for re-stocking and handling with the following qualifications.
- Returns must be pre-authorized by us in writing.
- We do not accept *collect* shipments.
- Items returned for warranty purposes must be insured and shipped pre-paid to the nearest warehouse
- Returns must be accompanied with a copy of your original invoice as proof of purchase. Returns must be in an un-used condition and shipped in their original packaging a letter explaining your reason for the return. Incurred shipping and handling charges are not refundable.
- Busy Bee will repair or replace the item at our discretion and subject to our inspection.
- Repaired or replaced items will be returned to you pre-paid by our choice of carriers.
- Busy Bee reserves the right to refuse reimbursement or repairs or replacement if a third party without our prior authorization has carried out repairs to the item.
- Repairs made by Busy Bee are warranted for 30 days on parts and labour.
- Any unforeseen repair charges will be reported to you for acceptance prior to making the repairs.
- The Busy Bee Parts & Service Departments are fully equipped to do repairs on all products purchased from us with the exception of some products that require the return to their authorized repair depots. A Busy Bee representative will provide you with the necessary information to have this done.
- For faster service it is advisable to contact the nearest Busy Bee location for parts availability prior to bringing your product in for repairs.